

Medical IT Insulation Monitoring & Alarm Overall Solution

Group 2 medical locations, insulation monitoring, alarm, fault detection.

Ver. Date: Nov,9th 2023

Acrel Co., Ltd.

No.253 Yulv Road, Jiading
District, Shanghai, China



0. Application Scenario

(1) According to IEC 60364-7-710 : 2002, hospital medical locations could be divided into Group 0, Group 1 and Group 2 locations. ["Group 2 Medical Location" refers to locations where the applied parts of medical electrical equipment are intended to be in direct contact with patients, and where continuity of power supply is critical. This includes areas like operating theaters, intensive care units [ICU], and other critical care areas.]

(2) A IT power system instead of TN-S system will be used for Group 2 medical locations. [So that no potential leakage current threat happened to vulnerable patients by embedded electrical medical equipment.]

(3) The insulation monitoring, alarm and fault detection for IT power system will be necessary to ensure the whole IT power system's normal running and maintenance.

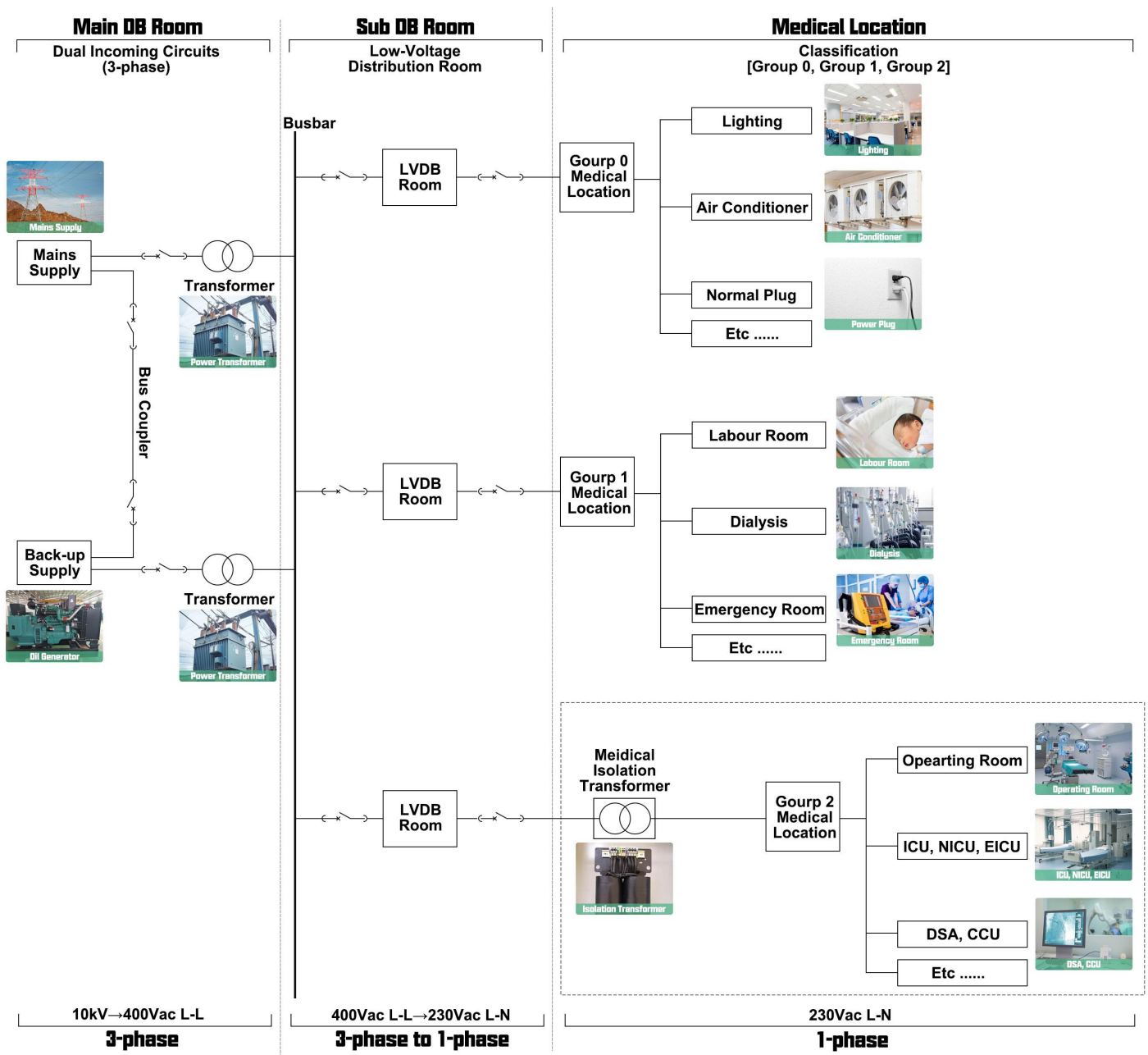

0. Solution Selection Logic

Judging by application scenario and function requirement, solution could be divided into 4 basic solution:

- (1) **Functional/Economic** Insulation Monitoring&Alarm Solution for Operation Room [with/without insulation fault location function]
- (2) **Functional/Economic** Insulation Monitoring&Alarm Solution for ICU, NICU, CCU, etc. [with/without insulation fault location function]

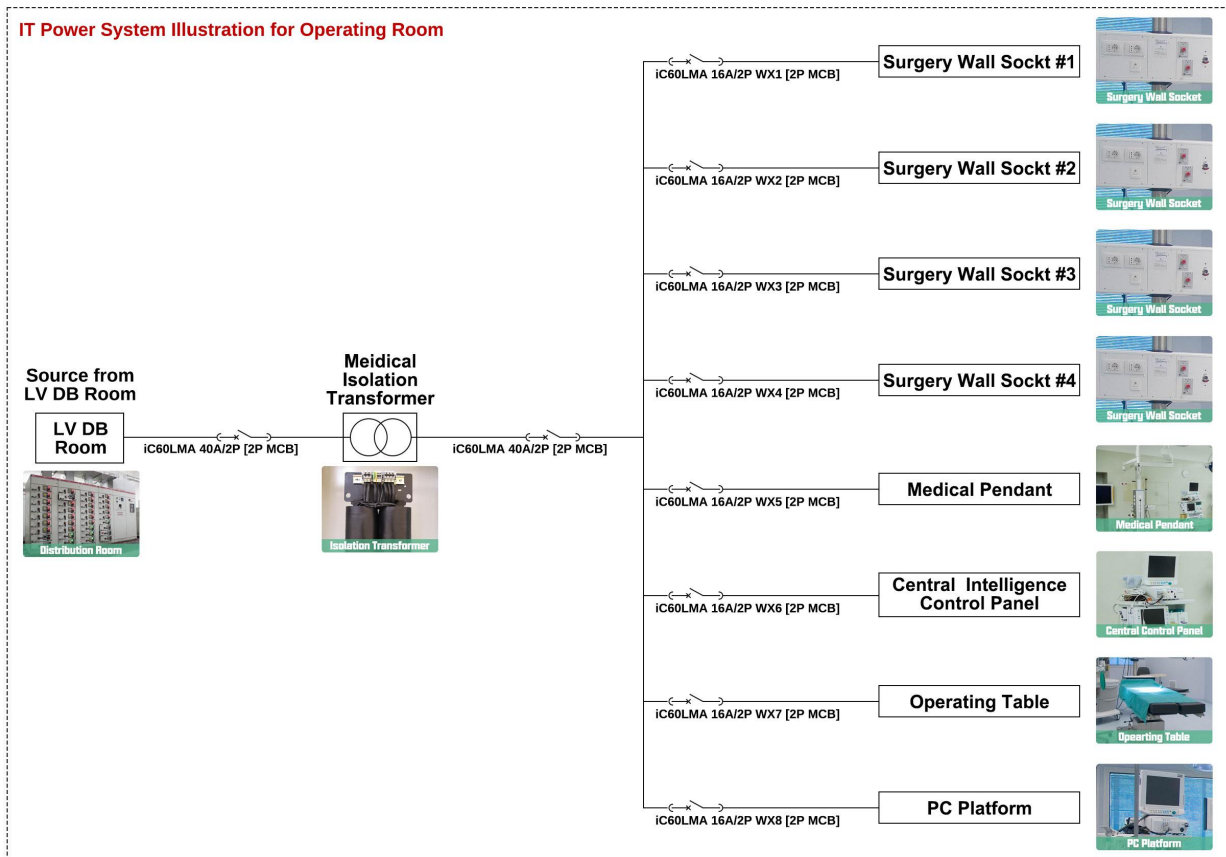

(1) Operating Room IT Power System Diagram Example

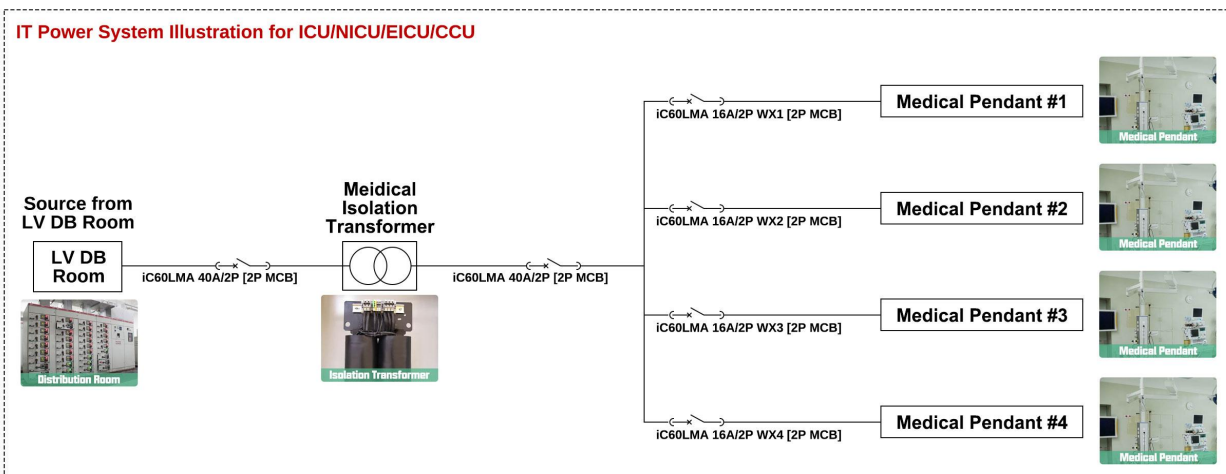

(2) ICU/EICU/NICU/CCU IT Power System Diagram Example

1. Scenario Preset [Operating Room Insulation Monitoring&Alarm solution with Fault Location]

- (1) The target was to monitor one IT power system in the operating room of a hospital. [including insulation level of IT power system, temperature of isolation transformer, current of load and etc.]
- (2) Rated voltage of IT power system was 230Vac.
- (3) 6.3kVA will be enough for the overall IT power system.
- (4) There are 6 1-phase sub circuits [for 6 different medical load respectively] to power up the important equipment in this IT power system. Also, insulation fault location function was requested.

1. Devices Deployment [Operating Room Insulation Monitoring&Alarm solution with Fault Location]

Operating Room #1 - IT Power Cabinet #1-1:

- 1* AITR6300S Medical Isolating Transformer [For modifying into IT Power System]
- 1* AIM-M300/SG Medical Insulation Monitor [For monitoring IT system insulation level and monitoring medical isolation transformer]
- 1* AID150 Centralized Alarm and Display Unit [For centralized insulation alarm and monitoring data display]
- 1* AIL160-6 Insulation Fault Locator [For locating the insulation fault, paired with AIM-M300/SG]
- 1* AHK-0.66/P26 Current Transformer [Paired with AIM-M300/SG for current signal input]
- 1* HDR-60-24 Power Supply Module [paired with AIM-M300/SG, AID150, AIL160-6 for 100~240Vac power supply input]

IT Power System Illustration for Operating Room

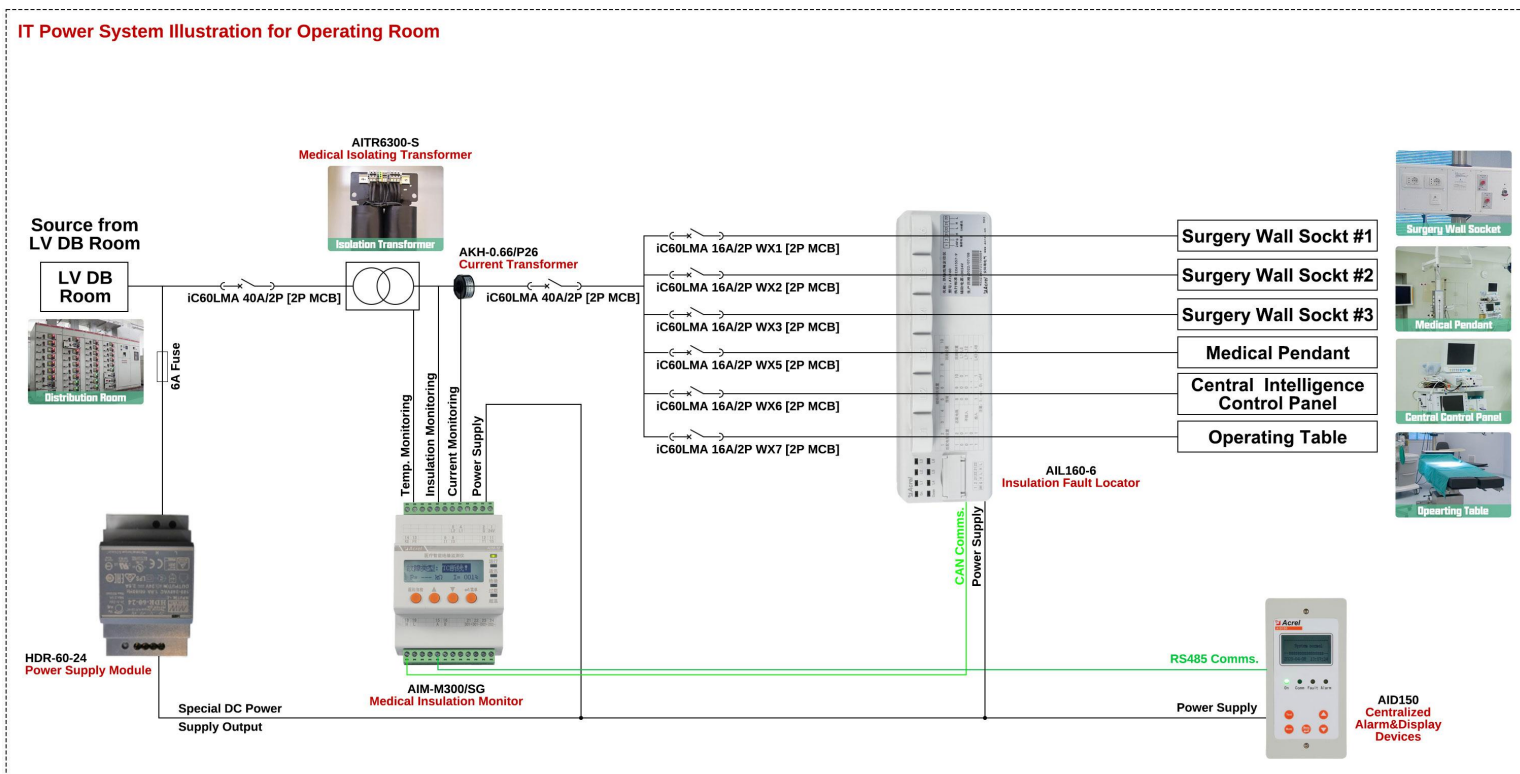

(1) Devices deployment in operating room for insulation monitoring [with fault location function]

2. Scenario Preset [Operating Room Insulation Monitoring & Alarm solution without Fault Location]

- (1) The target was to monitor one IT power system in the operating room of a hospital. [including insulation level of IT power system, temperature of isolation transformer, current of load and etc.]
- (2) Rated voltage of IT power system was 230Vac.
- (3) 6.3kVA will be enough for the overall IT power system.
- (4) There are 6 1-phase sub circuits [for 6 different medical load respectively] to power up the important equipment in this IT power system.

2. Devices Deployment [Operating Room Insulation Monitoring & Alarm solution without Fault Location]

Operating Room #1 - IT Power Cabinet #1-1:

- 1* AITR 6300S Medical isolating transformer [For modifying into IT Power System]
- 1* AIM-M300 Medical Insulation Monitor [For monitoring IT system insulation level and monitoring medical isolating transformer]
- 1* AID150 Centralized Alarm and Display Unit [For centralized insulation alarm and monitoring data display]
- 1* AHK-0.66/P26 Current Transformer [Paired with AIM-M100 for current signal input]
- 1* HDR-60-24 Power Supply Module [paired with AIM-M300, AID150 for 100~240Vac power supply input]

IT Power System Illustration for Operating Room

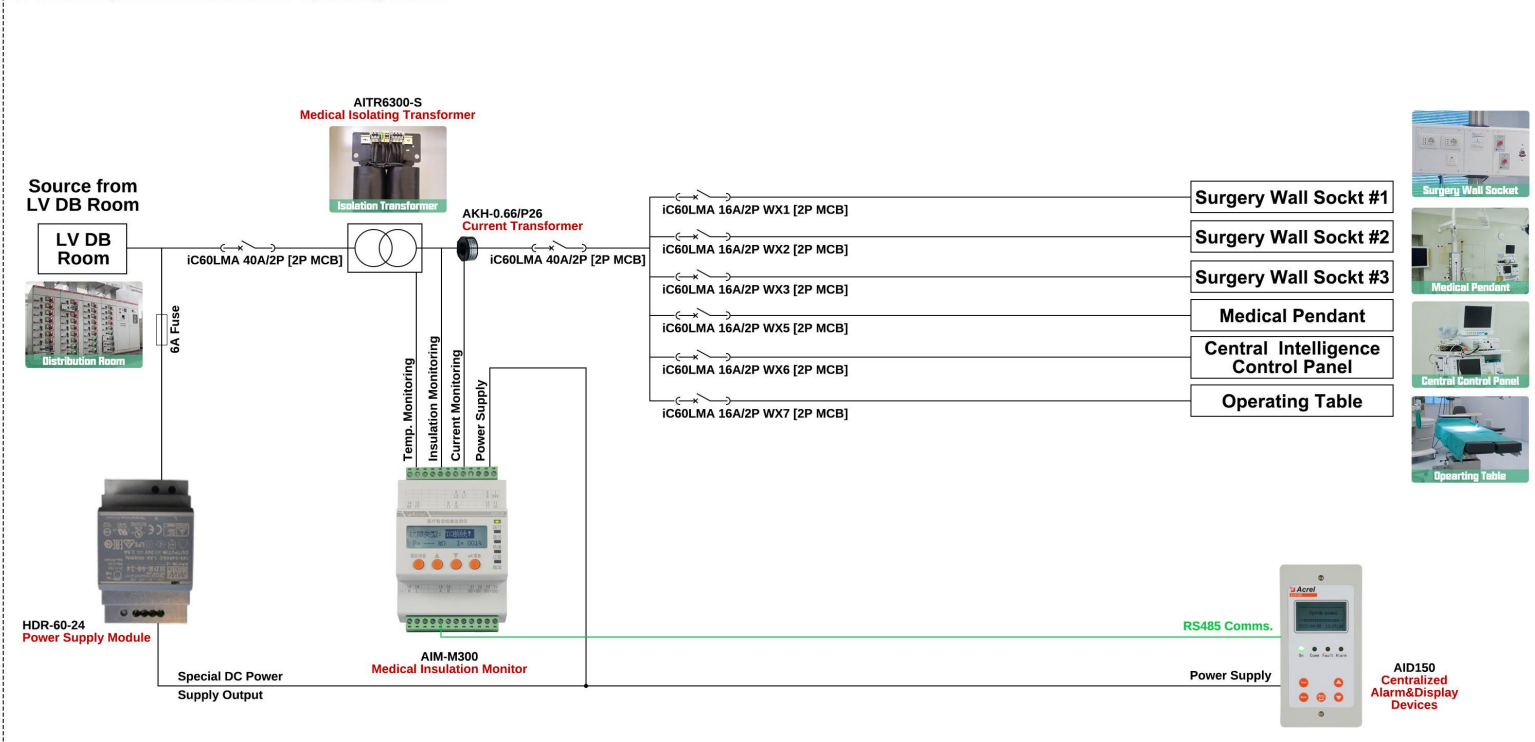

(1) Devices deployment in operating room for insulation monitoring [without fault location function]

3. Scenario Preset [ICU Insulation Monitoring&Alarm solution with Fault Location]

- (1) The target was to monitor one IT power system in the operating room of a hospital. [including insulation level of IT power system, temperature of isolation transformer, current of load and etc.]
- (2) Rated voltage of IT power system was 230Vac.
- (3) 6.3kVA will be enough for the overall IT power system.
- (4) There are 6 1-phase sub circuits [for 6 different medical load respectively] to power up the important equipment in this IT power system. Also, insulation fault location function was requested.

3. Devices Deployment [ICU Insulation Monitoring&Alarm solution with Fault Location]

ICU Room #1 - IT Power Cabinet #1-1:

- 1* AITR 6300S Medical isolating transformer [For modifying into IT Power System]
- 1* AIM-M300/SG Medical Insulation Monitor [For monitoring IT system insulation level and monitoring medical isolating transformer]
- 1* AID150 Centralized Alarm and Display Unit [For centralized insulation alarm and monitoring data display]
- 1* AIL160-6 Insulation Fault Locator [For locating the insulation fault, paired with AIM-M300/SG]
- 1* AHK-0.66/P26 Current Transformer [Paired with AIM-M300/SG for current signal input]
- 1* HDR-60-24 Power Supply Module [paired with AIM-M300/SG, AID150, AIL160-6 for 100~240Vac power supply input]

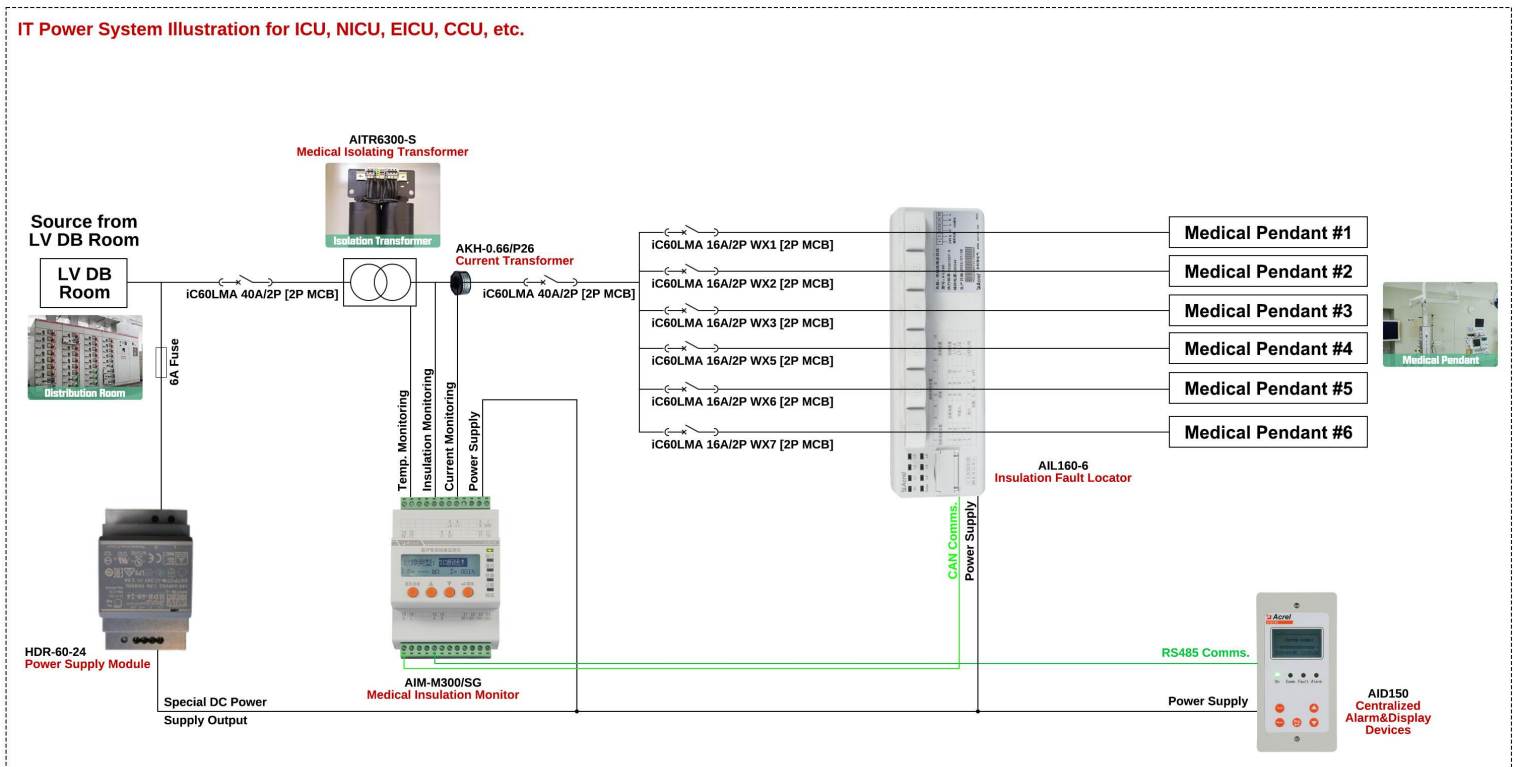

(1) Devices deployment in operating room for insulation monitoring [with fault location function]

4. Scenario Preset [ICU Insulation Monitoring&Alarm solution without Fault Location]

- (1) The target was to monitor one IT power system in the operating room of a hospital. [including insulation level of IT power system, temperature of isolation transformer, current of load and etc.]
- (2) Rated voltage of IT power system was 230Vac.
- (3) 6.3kVA will be enough for the overall IT power system.
- (4) There are 6 1-phase sub circuits [for 6 medical pendant of ICU bed respectively] to power up the important equipment in this IT power system.

4. Devices Deployment [ICU Room Insulation Monitoring&Alarm solution without Fault Location]

ICU Room #1 - IT Power Cabinet #1-1:

- 1* AITR 6300S Medical isolating transformer [For modifying into IT Power System]
- 1* AIM-M300 Medical Insulation Monitor [For monitoring IT system insulation level and monitoring medical isolating transformer]
- 1* AID150 Centralized Alarm and Display Unit [For centralized insulation alarm and monitoring data display]
- 1* AHK-0.66/P26 Current Transformer [Paired with AIM-M100 for current signal input]
- 1* HDR-60-24 Power Supply Module [paired with AIM-M300/SG, AID150, AIL160-6 for 100~240Vac power supply input]

IT Power System Illustration for ICU, NICU, EICU, CCU, etc.

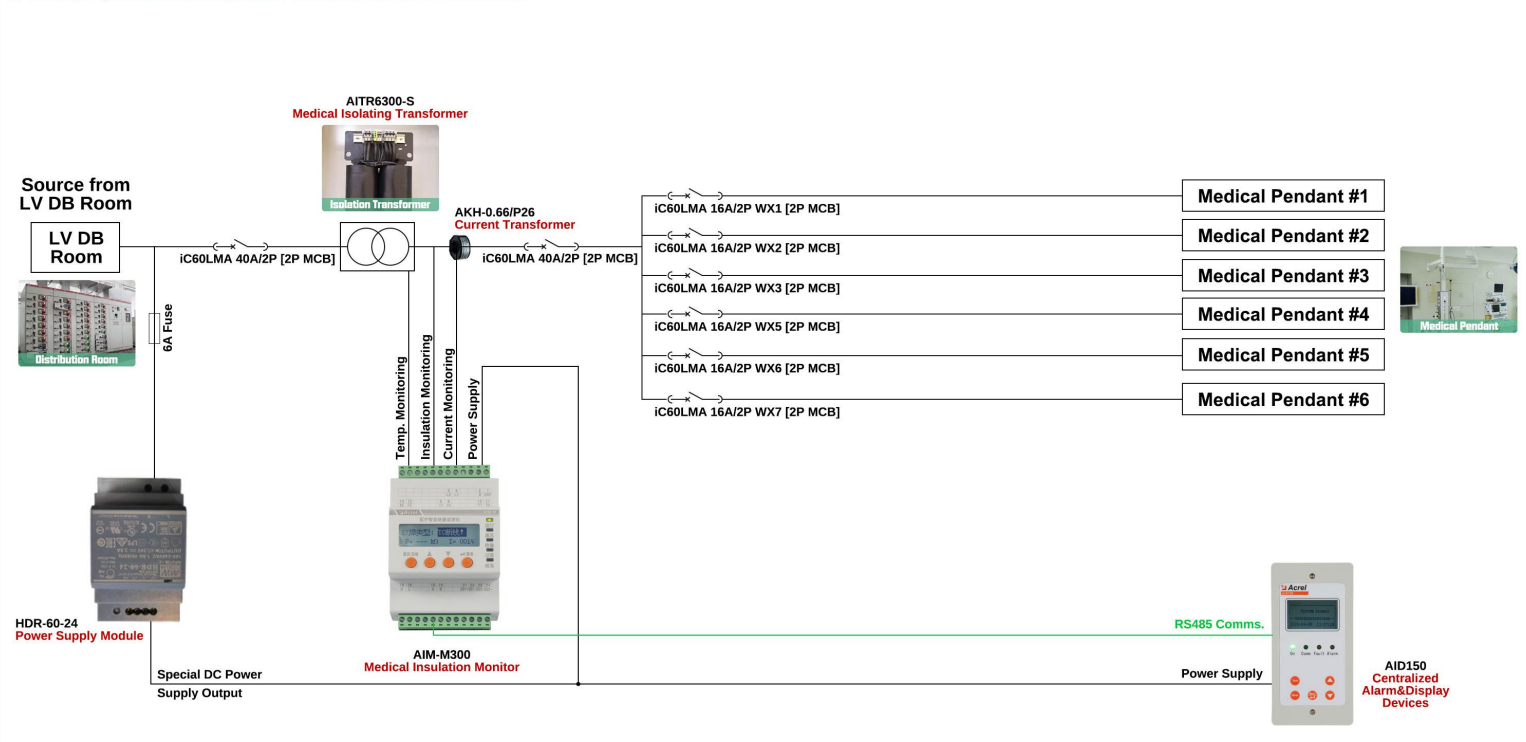

(1) Devices deployment in operating room for insulation monitoring [without fault location function]

5. Hardware Devices Overview

Model 1: AITR Series Medical Isolating transformer

- Rated Power: 10kVA/8kVA/6.3kVA/3.15kVA [Optional]
- Rated Input Voltage: 230Vac
- Rated Frequency: 50Hz/60Hz
- Rated Input Current: 45.3A/36A/28.5A/22.5A/14.2A [According to rated power]
- Efficiency: 96%
- Leakage Current: <200 μ A
- Noise Level: <40dB
- Max Operating Temperature: <40
- Temperature Monitoring Reservation: with 2 embeded PT100 Temp. Sensor.



Model 2: AIM300/SG Medical Insulation Monitor

- Insulation Resistance Measuring Range: 15-999k -
- Insulation Alarm Rangenet: 50-999k
- Measuring Current: < or = 5uA
- Measuring Voltage: < or = 12V
- Temp. Measuring Range: -50~+200 \ddot{y} [via 2 PT100]
- Load Measuring Current Range: 2.1~60A AC
- Alarm Output: 2 way relay alarm output
- Communications: 1-way CAN; 1-way RS485
- Auxiliary Power Supply: 18~36Vdc
- Fault Location Detect Signal Generation: Function code /SG

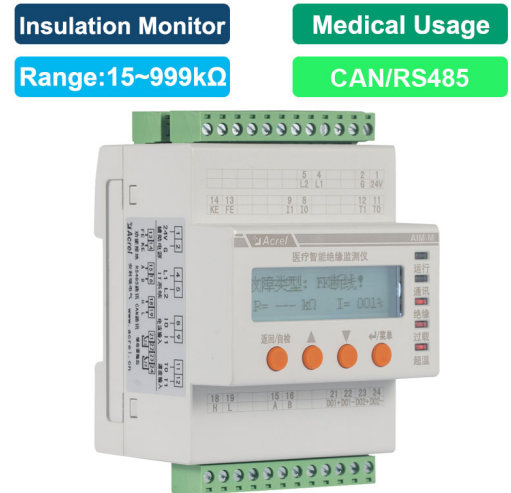

Model 3: AIM100 Medical Insulation Monitor

- Insulation Resistance Measuring Range: 10-999k -
- Insulation Alarm Rangenet: 50-999k
- Measuring Current: < or = 50uA
- Measuring Voltage: < or = 12V
- Temp. Measuring Range: -50~+200 \ddot{y} [via 2 PT100]
- Load Measuring Current Range: 2.1~50A AC
- Alarm Output: 2 way relay alarm output
- Communications: 2-way RS485
- Auxiliary Power Supply: 220Vac [\pm 10%]

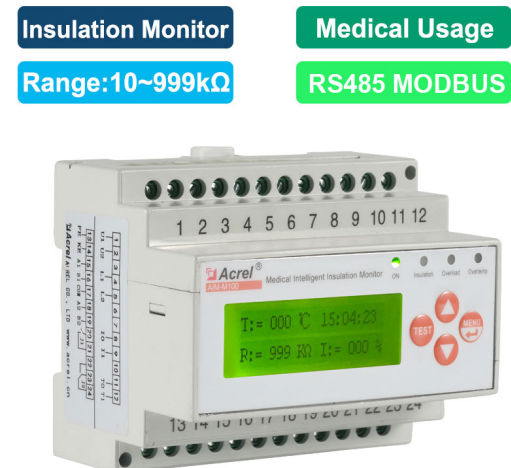

5. Hardware Devices Overview

Model 4: AID150 Centralized Alarm&Display Devices

- Communications: RS485 [MODBUS-RTU]
- Monitor: up to 1~16 AIM100 or AIM300/SG
- Auxiliary Power Supply: 24Vdc
- Mount Type: Wall mounted
- Cut-out Dimension: 74.5mm×158.5mm

Alarm&Display

Medical Usage

Sound&Light Alarm

RS485 Comms.



Model 5: AIL160-6 Medical Insulation Fault Locator

- Fault Location: up to 6 channel fault locating circuits 1-phase
- Fault Locating Response Time: <5S
- Communicaitons: CAN comms [Self-define protocol]
- Rated Voltage: 0~242Vac
- Rated Frequency: 45~60Hz
- Auxiliary Power Supply: 18~36Vdc

Fault Locator

Medical Usage

Up to 6-channel

CAN Comms.



Model 6: HDR-60-24 Power Supply Module

- Input Range: 100~240Vac [1.8A]
- Output Range: 24Vdc [2.5A]
- Installation: 35mm DIN-rail installation

Input Range

Output Range

100~240Vac

24Vdc



5. Hardware Devices Overview

Model 7: HDR-60-24 Power Supply Module

- Input Range: 220Vac [$\pm 10\%$]
- Output Range: 24Vdc [2.5A]
- Installation: 35mm DIN-rail installation

Input Range	Output Range
220Vac [$\pm 10\%$]	24Vdc [$\pm 5\%$]



6. Project Sample #1 - Brazil Hospital IT Power System Insulation Monitoring Project

(1) Project Overview:

- Customer: CSE Soluções Elétricas Ltd [Contractor]
- Country: Brazil
- Project Aim: Supplying the complete set of Hospital Insulation Power Cabinet for IT power system modification and monitoring.
- Project Amount: About 720.000 USD



(1) Customer: Info service & Computer Srl [Contractor]



(1) Project Aim: Hospital IT Power System Monitoring

(2) Applied Product Combination:

- AIM-M10 Medical Insultation Monitor [For monitoring IT system insulation level and monitoring medical isolating transformer]
- AIM-M100 Medical Insultation Monitor [For monitoring IT system insulation level and monitoring medical isolating transformer]
- ASG150 Insulation Signal Generator
- AIL150-8 Insulation Fault Locator
- AID150 Centralized Alarm and Display Unit
- AID200 Centralized Alarm and Display Unit
- AKH-0.66/P26 Current Transformer
- ACLP10-24 Power Supply Module

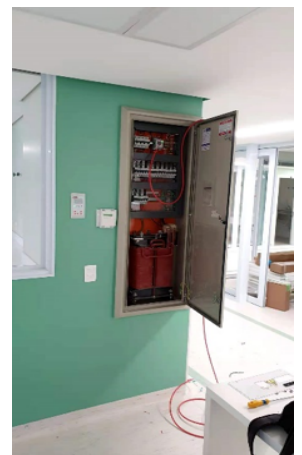
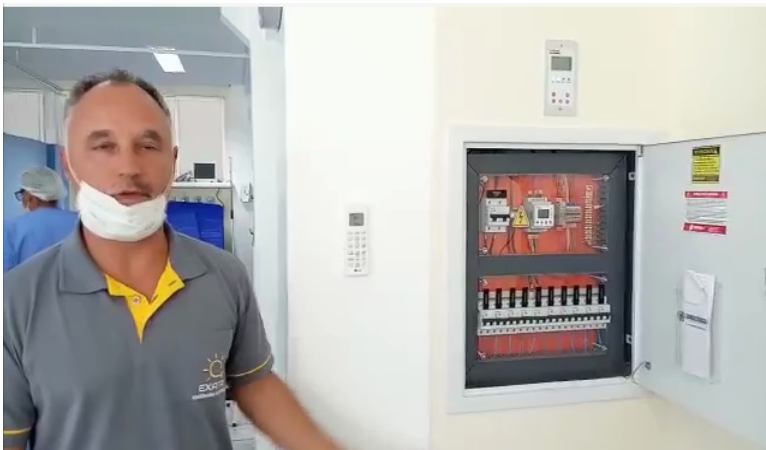

(2) Site Installation Picture

6. Project Sample #3 - Romania Hospital IT Power System Insulation Monitoring Project

(1) Project Overview:

- Customer: Info service & Computer Srl [Contractor]
- Country: Romania
- Project Aim: Supplying the complete set of Hospital Insulation Power Cabinet for IT power system modification and monitoring.
- Project Amount: About 10.000 USD



(1) Customer: Info service & Computer Srl [Contractor]



(1) Project Aim: Hospital IT Power System Monitoring

(2) Applied Product Combination:

- GT180 Series Medical Insulation Power Cabinet [Cabinet including all necessary parts.]
- AITR 6300S Medical isolating transformer [For modifying into IT Power System]
- AIM-M300/SG Medical Insulation Monitor [For monitoring IT system insulation level and monitoring medical isolating transformer]
- AID150 Centralized Alarm and Display Unit [For centralized insulation alarm and monitoring data display]
- AIL160-6 Insulation Fault Locator [For locating insulation fault, paired with AIM-M300/SG]
- AHK-0.66/P26 Current Transformer [Paired with AIM-M300/SG for current signal input]
- HDR-60-24 Power Supply Module [paired with AIM-M300/SG, AID150, for power supply]
- CBs and Cables [according to the design of single line diagram]

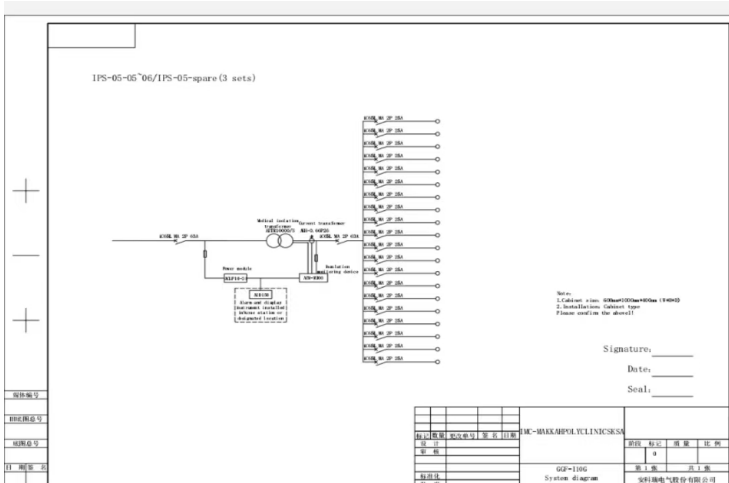

(2) Single Line Diagram Example



(2) Customer Side

6. Project Sample #4 - Morocco Hospital IT Power System Insulation Monitoring Project

(1) Project Overview:

- Customer: Ste Bridgelec [Contractor]
- Country: Morocco
- Project Aim: Supplying the complete set of Hospital Insulation Power Cabinet for IT power system modification and monitoring.
- Project Amount: About 10.000 USD



(1) Customer: Ste Bridgelec
[Contractor]



(1) Project Aim: Hospital IT
Power System Monitoring

(2) Applied Product Combination:

- GT150 Series Medical Insulation Power Cabinet [Cabinet including all necessary parts]
- AITR 6300S Medical isolating transformer [For modifying into IT Power System]
- AIM-M300/SG Medical Insulation Monitor [For monitoring IT system insulation level and monitoring medical isolating transformer]
- AID150 Centralized Alarm and Display Unit [For centralized insulation alarm and monitoring data display]
- AIL160-6 Insulation Fault Locator [For locating insulation fault, paired with AIM-M300/SG]
- AHK-0.66/P26 Current Transformer [Paired with AIM-M300/SG for current signal input]
- HDR-60-24 Power Supply Module [paired with AIM-M300/SG, AID150, for power supply]
- CBs and Cables [according to the design of single line diagram]

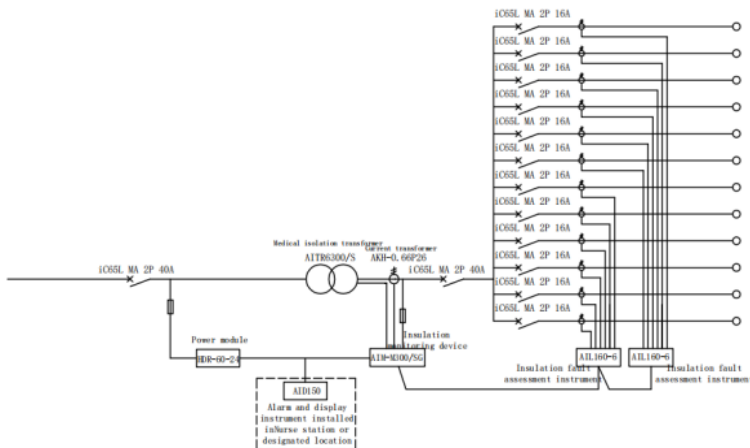

(2) Single Line Diagram Example



(2) Site Installation Picture