

ATP 系列无线测温集中采集触摸屏
ATP series wireless temperature measurement
centralized collection touch screen

安装使用说明书 V1.4
Installation Instruction V1.4

申 明

DECLARATION

版权所有，未经本公司之书面许可，此手册中任何段落，章节内容均不得被摘抄、拷贝或以任何形式复制、传播，否则一切后果由违者自负。

本公司保留一切法律权利。

All rights reserved. No part of this publication may be reproduced, stored in a retrieval system, or transmitted in any form by any means, electronic, mechanical photocopying, recording, or otherwise without prior permission of our company. The violator will bear the dependent legal responsibility.

We reserve all the rights.

本公司保留对本手册所描述之产品规格进行修改的权利，恕不另行通知。

订货前，请垂询当地代理商以获悉本产品的最新规格。

We reserve all the rights to revise product specification without notice. Please consult local agent to get the latest information of our products specification.

目录

1 安装使用指南	1
1 Installation Guide	1
1.1 产品概述	1
1.1 Product Introduction	1
1.2 主要技术指标	1
1.2 Technical Features	1
1.3 产品拓扑图	6
1.3 Product topology	6
1.3.1 搭配 ATC600-C 方案	6
1.3.1 With ATC600-C scheme	6
1.3.2 搭配 ATC600-M 方案	7
1.3.2 With ATC600-M scheme	7
1.4 产品安装	7
1.4 Product Installation	7
1.4.1 触摸屏尺寸及开孔	7
1.4.1 Touch screen size and hole size	7
1.4.2 无线温度收发器的安装	9
1.4.2 Installation of wireless temperature transceiver	9
1.4.3 无线温度传感器的安装	10
1.4.3 Installation of wireless temperature sensor	10
1.5 触摸屏背部端子图	11
1.5 back terminal diagram of touch screen	11
2 产品操作指南	12
2.1 温度显示	12
2.1 Temperature display	12
2.2 定值设置	13
2.2 Setting value	13
2.3 报警信息	16
2.3 Alarm information	16
2.4 温度曲线	18
2.4 Temperature curve	18
3 通讯指南	19
3 Communication Examples	19
3.1 通讯格式详解	19
3.1 Detailed communication format	19
3.1.1 读取数据（功能码 04H（只读寄存器）/03H（读写寄存器））	20
3.1.1 Read State (Function code 04H (Read only register) /03H (Read write register))	20
3.1.2 预置单个寄存器（功能码 06H）	20
3.1.2 Preset Single Register (Function code 06H)	20
3.1.3 预置多个寄存器（功能码 10H）	21

3.1.3 Preset Multi Registers (Function code 10H).....	21
3.2 通讯地址表.....	21
3.2 Communication address list.....	21
3.2.1 搭配 ATC600-C 地址表.....	21
3.2.1 With ATC600-C address table.....	21
3.2.2 搭配 ATC600-M 地址表.....	22
3.2.2 With ATC600-M address table.....	22
3.3 通讯设置.....	23
3.3 Communication settings.....	23

1 安装使用指南

1 Installation Guide

1.1 产品概述

1.1 Product Introduction

ATP 系列无线测温集中采集触摸屏适用于高压开关柜触点及接点、刀闸开关、高压电缆中间头、干式变压器、低压大电流等设备的温度监测。该触摸屏可以与无线测温收发器搭配使用，实现 240 个无线测温传感器数据采集，匹配的传感器包括 ATE200、ATE200P、ATE300P、ATE400、ATE300M、ACE100 等。无线温度传感器与收发器交换通过无线信号传送，不会影响系统的绝缘性能，使用更安全。装置具有隔离彻底、安装方便、抗干扰能力强、工作可靠等特点，解决了高电压状态下的接触式温度监测的安全问题。

ATP series wireless temperature measurement centralized collection touch is applicable to temperature monitoring of contacts points and connection points of High-Voltage Switchgear, knife switch and middle head of high voltage cable、dry-type transformer、Low voltage and high current and other equipment.The touch screen can be used with wireless temperature measurement transceiver to realize data acquisition of 240 wireless temperature measurement sensors, including ATE200, ATE200P, ATE300P, ATE400,ATE300M,ACE100 etc.Wireless temperature sensor and transceiver exchange through wireless signal transmission, will not affect the insulation performance of the system and use safer.The device has the characteristics of complete isolation, convenient installation, strong anti-interference ability and reliable operation, which solves the safety problem of contact temperature monitoring under high voltage state.

1.2 主要技术指标

1.2 Technical Features

表 1 ATP 系列无线测温集中采集触摸屏技术指标

Table 1 technical indicators of ATP series wireless temperature measurement centralized collection touch

项目 Items	指标 Features
触摸屏型号 Type of touch screen	ATP007, ATP010
工作电源 Power source	DC 24V (±10%) , 5W/6W

传感器个数 Number of sensors		240
温度分辨率 Resolution		0.1℃
温度精度 Precision		±1℃
通讯 communication	接口 Interface	RS485/以太网 RS485/Ethernet
	协议 Protocol	Modbus-RTU/ Modbus-TCP
环境要求	工作温度 Temperature	0℃~50℃
	相对湿度 Humidity	≤95%
	海拔高度 Altitude	≤3000m
有源无线测温传 感器 Active wired temperature sensor	有源传感器型号 Active sensor type	ATE200
	无线频率 Wireless frequency	470MHz/433MHz
	通讯距离 Communication distance	空旷 150m (433MHz 时, 距离 50 米) 150m in open area (433MHz: 50m)
	采样频率 Sampling frequency	25s
	发射频率 Transmission frequency	25s-5min
	工作电源 Power source	电池 battery
	安装方式 Installation	表带式 Belt
	测温范围 Range of temperature	-50℃~+125℃
	精度 Precision	±1℃
	应用范围 Application	高低压柜内电气接头 Joints in high or low voltage switchgears

	电池寿命 Battery life	≥5 年 (25℃) ≥5 years (25℃)
分体式有源无线 测温传感器 Split active wired temperature sensor	传感器型号 Sensor type	ATE300P
	无线频率 Wireless frequency	470MHz/433MHz
	传输距离 Communication distance	500m (空旷) 150m in open area
	采样频率 Sampling frequency	25s
	发射频率 Transmission frequency	25s-5min
	安装方式 Installation	导轨式/扎带式 Guide rail type/tie belt type
	工作电源 Power source	电池 Battery
	电池寿命 Battery life	≥5 年 (25℃) ≥5 years (25℃)
	测温范围 Range of temperature	-50℃~300℃
	精度 Precision	±1℃
	传感器探头 Sensor probe	PT100
	应用范围 Application	高低压柜内电气接头等 Electrical connectors in high and low voltage cabinets, etc
无源无线测温传 感器 Passive wireless temperature sensor	无源传感器型号 Passive sensor type	ATE400
	无线频率 Wireless frequency	470MHz/433MHz
	通讯距离 Communication distance	空旷 150m (433MHz 时, 距离 50 米) 150m in open area (433MHz: 50m)
	采样频率 Sampling frequency	15s
	发射频率 Transmitting frequency	15s
	工作电源	感应取电, 启动电流>5A

	Power source	CT-powered, starting current \geq 5A
	安装方式 Installation	合金片固定 alloy chip fixing
	传感器探头 Sensor probe	合金底座 Alloy base
	测温范围 Range of temperature	-50 $^{\circ}$ C~125 $^{\circ}$ C
	精度 Precision	\pm 1 $^{\circ}$ C
	应用范围 Application	高低压柜内电气接头 Joints in high or low voltage switchgears
无线温度传感器 Wireless temperature sensor	有源传感器型号 Active sensor type	ATE200P
	无线频率 Wireless frequency	470MHz/433MHz
	通讯距离 Communication distance	空旷 150m (433MHz 时, 距离 50 米) 150m in open area (433MHz: 50m)
	采样频率 Sampling frequency	25s
	发射频率 Transmitting frequency	25s-5min
	工作电源 Power source	电池 Battery
	安装方式 Installation	表带式 Belt
	测温范围 Range of temperature	-50 $^{\circ}$ C~+150 $^{\circ}$ C
	精度 Precision	\pm 0.5 $^{\circ}$ C
	应用范围 Application	电气接头 Voltage switchgears
	电池寿命 Battery life	\geq 5 年 (25 $^{\circ}$ C) \geq 5 years (25 $^{\circ}$ C)
	防护等级 Protection level	IP68
多回路式温度传 感器	传感器型号 Sensor type	ATE300M
	无线频率 Wireless frequency	433-510MHz

Multi Loop temperature sensor	通讯距离 Communication distance	空旷 1000m 1000m in open area	
	采集频率 Sampling frequency	1~240s	
	工作电源 Power source	AC/DC 85~265V	
	安装方式 Installation	导轨式 (35mm) /扎带式 Guide rail type (35mm) /tie belt type	
	测温范围 Range of temperature	-40℃~+140℃	
	精度 Precision	±1℃	
	传感器探头 Sensor probe	分体式 NTC, 1~6 路选配 Split NTC, 1~6 channel optional	
	应用范围 Application	低压抽屉柜内电气接头 Joints in low voltage switchgears	
无线温度电流复合传感器 Wireless temperature & current sensor	传感器型号 Sensor type	ACE100-29	
	测量范围 Range	温度 Temperature	-50℃~125℃
		电流 Current	AC 1~400A
	精度 Precision	温度 Temperature	±1℃
		电流 Current	±1%FS
	分辨率 Resolution	温度 Temperature	0.1℃
		电流 Current	0.01A
	采集与发射周期 Sampling & Transmission cycle	感应取电: 10~30S; 电池: 3min CT-powered: 10~30S; Battery: 3min	
	感应取电启动电流 CT-powered, starting current	≥2.5A	
	电池寿命 Battery life	3 年 (25℃), 可更换 (型号 CR2450) 3 years(25℃), Replaceable(CR2450)	
	无线频率 Wireless frequency	470Mhz	
	传输距离 Communication distance	150m (空旷) 150m in open area	
	安装方式	卡扣式安装	

	Installation 安装线缆直径 Cable diameter	Open snap type 6~29mm
--	--	--------------------------

1.3 产品拓扑图

1.3 Product topology

1.3.1 搭配 ATC600-C 方案

1.3.1 With ATC600-C scheme

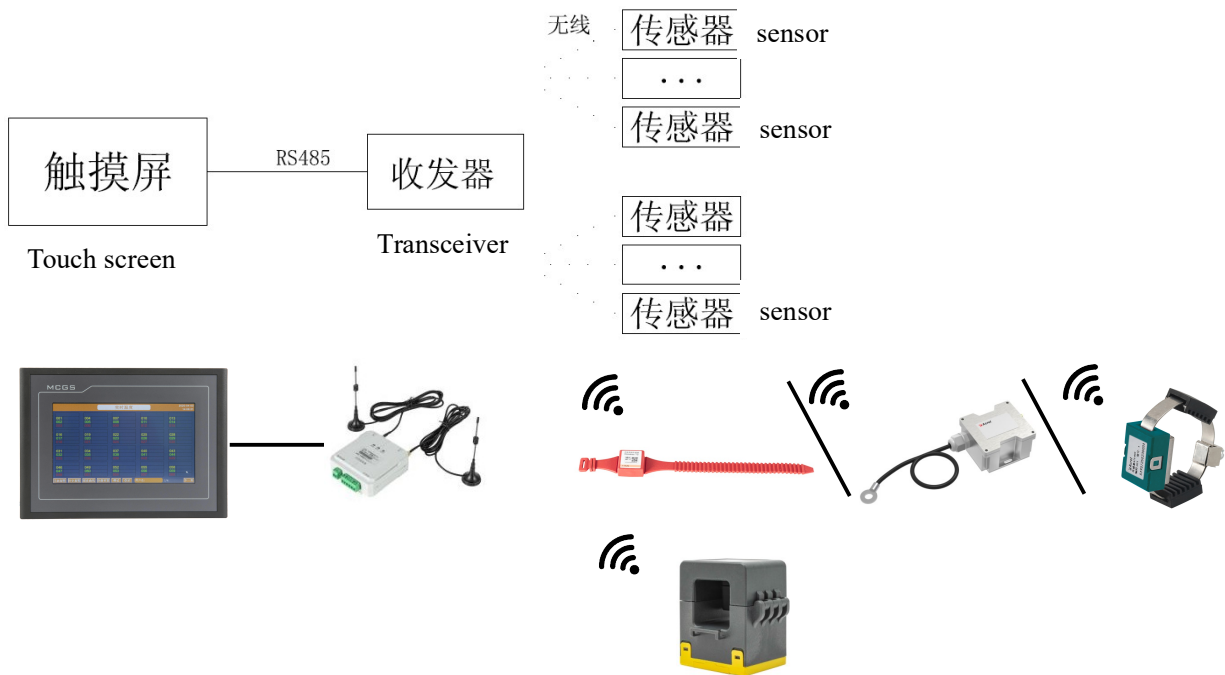

名称 Name	型号 Type	数量 Number
触摸屏 Touch screen	ATP007/ATP010	1
无线温度收发器 Wireless temperature transceiver	ATC600-C	1
中继收发器 Relay transceiver	ATC600-Z	按需
无线测温传感器 Wireless temperature transceiver	ATE200/ATE200P/ATE300P/ATE400/ACE100	240

1.3.2 搭配 ATC600-M 方案

1.3.2 With ATC600-M scheme

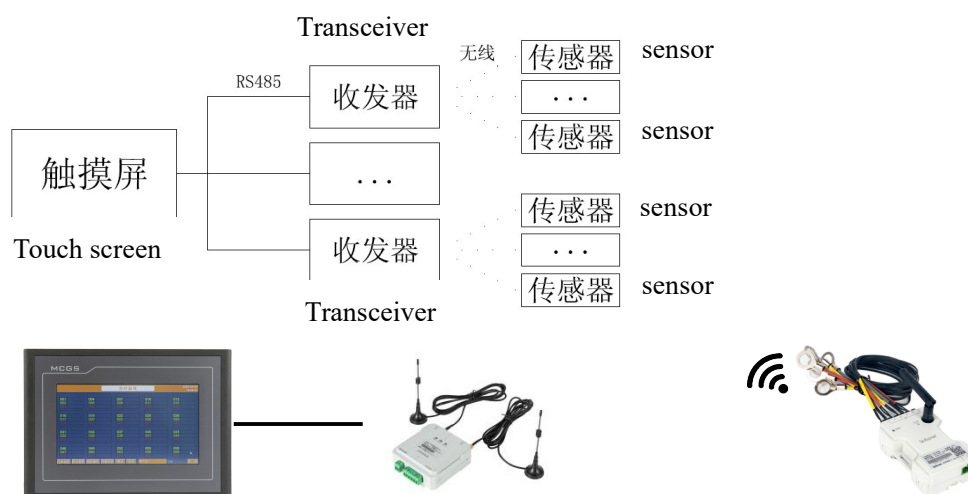

名称 Name	型号 Type	数量 Number
触摸屏 Touch screen	ATP010	1
无线温度收发器 Wireless temperature transceiver	ATC600-M	1
无线测温传感器 Wireless temperature transceiver	ATE300M	240
传感器探头 Sensor probe	NTC	1440

1.4 产品安装

1.4 Product Installation

1.4.1 触摸屏尺寸及开孔

1.4.1 Touch screen size and hole size

ATP 系列无线测温系统使用的触摸屏采用面板嵌入式安装，产品尺寸及安装开孔尺寸如图 1.1、图 1.2 所示。安装方法见图 1.3。

Touch screen ATP series wireless temperature measurement system uses panel embedded installation. The product size and installation hole size are shown in Figure 1.1 and Figure 1.2. The installation method is shown in Figure 1.3



图 1.1 ATP007 触摸屏开孔尺寸（单位 mm）

Figure 1.1 hole size of atp007 touch screen (unit: mm)

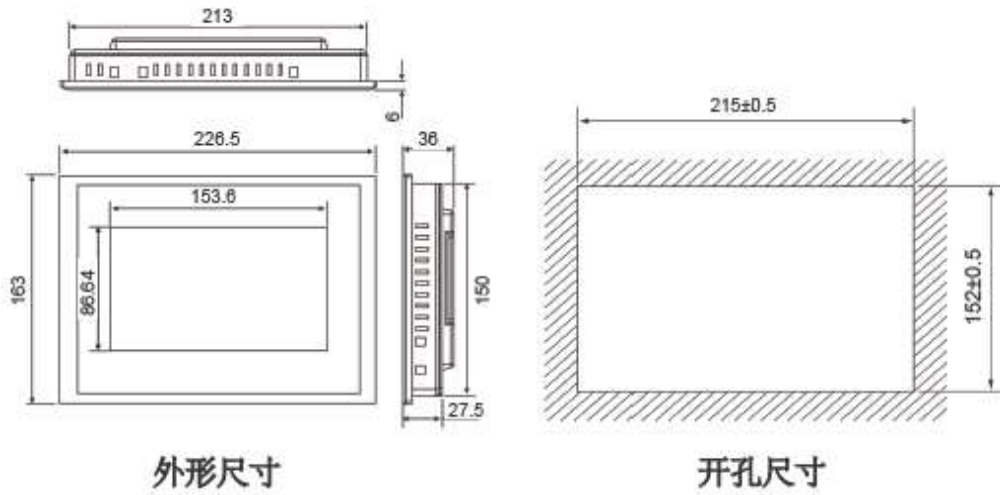

图 1.2 ATP010 触摸屏开孔尺寸（单位 mm）

Figure 1.2 hole size of atp010 touch screen (unit: mm)

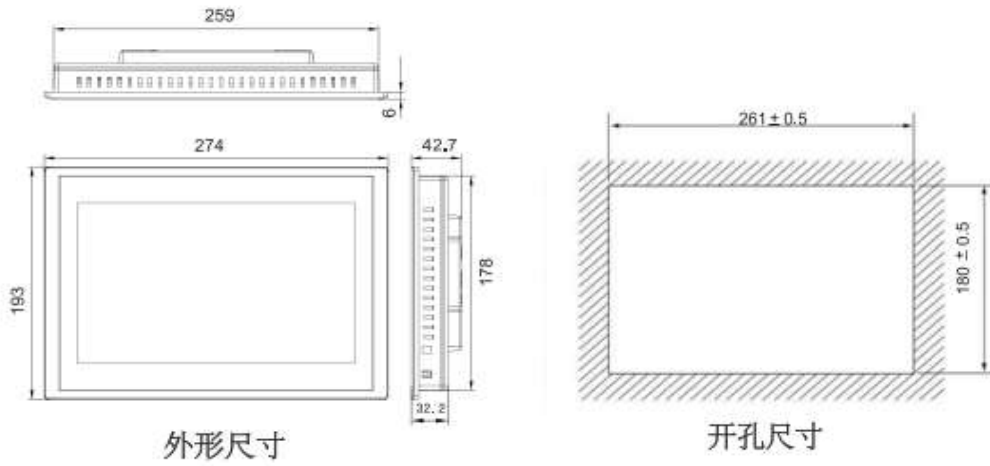

图 1.3 触摸屏安装方法

Figure 1.3 installation method of touch screen

1.4.2 无线温度收发器的安装

1.4.2 Installation of wireless temperature transceiver

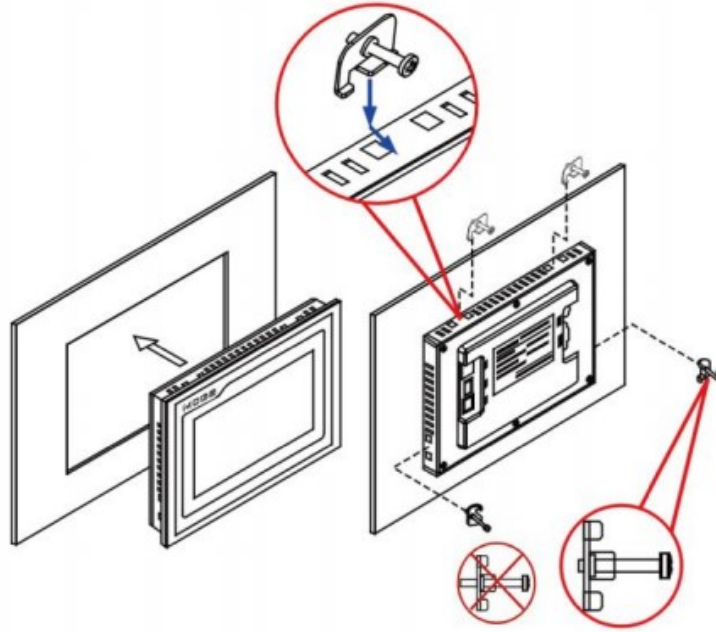
ATC600 无线测温接收器，采用导轨（DIN35mm）安装方式，主体尺寸 90mm*90mm*38mm，如图 1.4 所示。

ATC600 wireless temperature transceiver adopt guide rail (DIN35mm) installation, main dimension 90mm*90mm*38mm , as shown in Figure 1.4 .



图 1.4 ATC600 无线温度收发器外形及安装示例

Figure 1.4 appearance and installation example of wireless temperature transceiver

1.4.3 无线温度传感器的安装

1.4.3 Installation of wireless temperature sensor

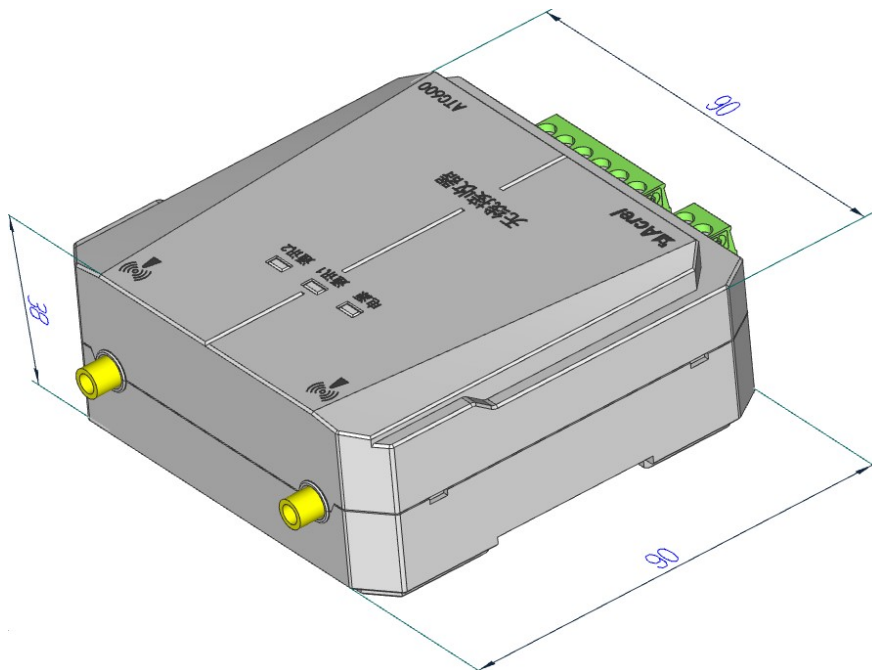
无线温度传感器共有多种型号，分别对应表带固定、合金片固定、导轨等安装方式。

Wireless temperature sensor has a variety of models, part are strap fixation, alloy plate fixation, guide rail and other installation method.



图 1.6 表带式无线温度传感器 ATE200/200P

Figure 1.6 Belt wireless temperature sensor ATE200/ATE200P

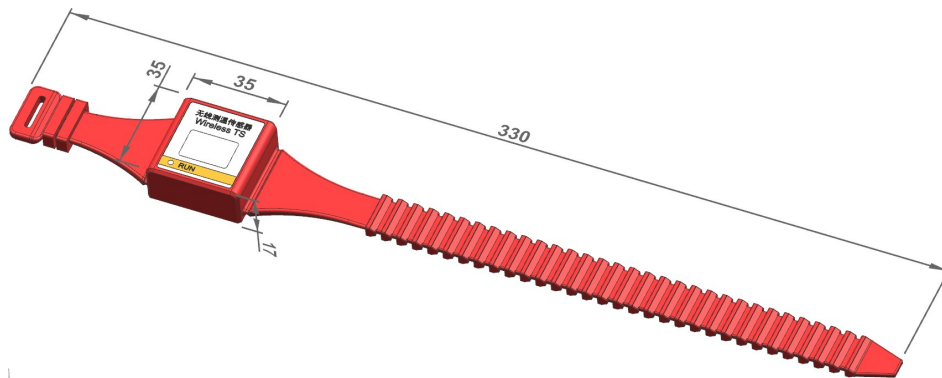

图 1.7 无源无线温度传感器 ATE400

Figure 1.7 passive wireless temperature sensor ATE400

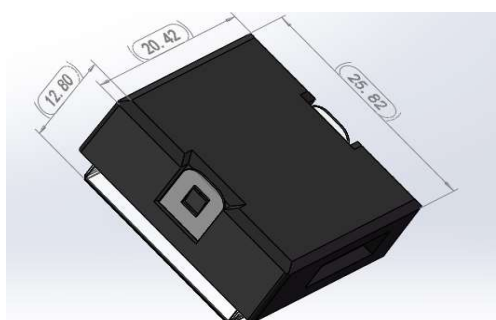

图 1.8 多回路式温度传感器 ATE300M

Figure 1.8 multiLoop temperature sensor ATE300M

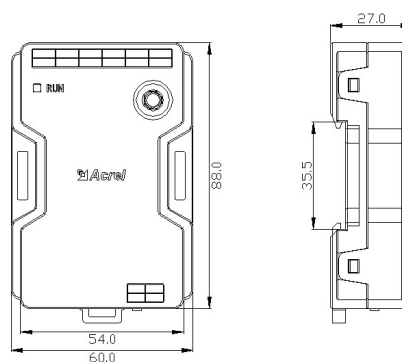

图 1.9 无线温度电流复合传感器 ACE100

Figure 1.9 wireless temperature & current sensor ACE100

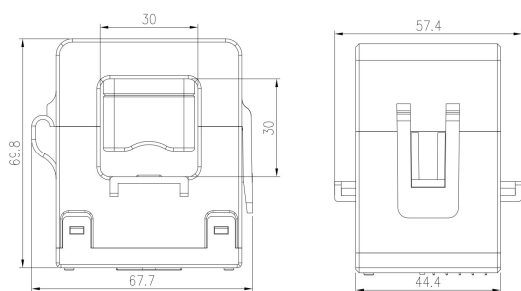

图 2.0 分体式有源无线测温传感器 ATE300P

Figure 2.0 Split active wired temperature sensor ATE300P

1.5 触摸屏背部端子图

1.5 back terminal diagram of touch screen

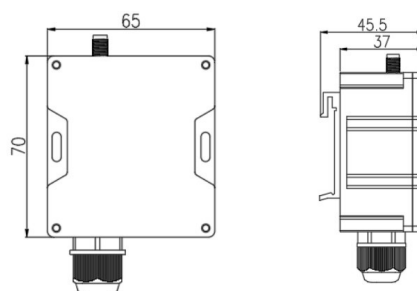

图 1.10 触摸屏背部端子

Figure 1.10 back terminal of touch screen

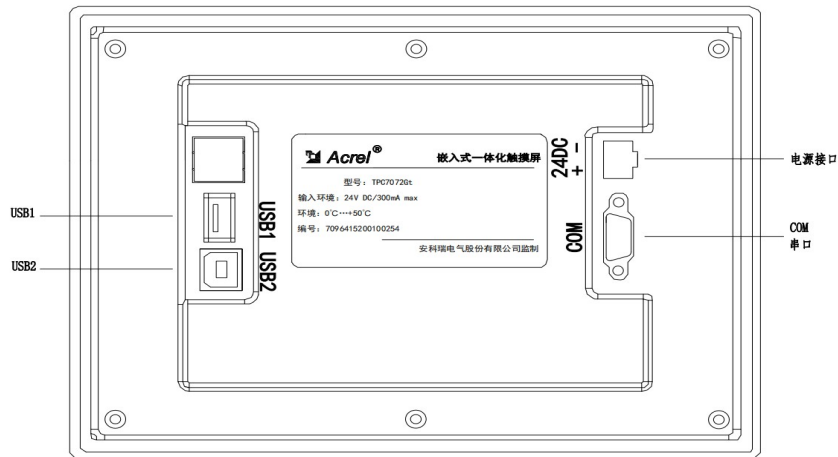

图 1.11 串口引脚

Figure 1.11 serial port pin

触摸屏出厂配置有一根转接线(INC0702Z), J1 接触摸屏串口, 其中红、蓝(7-8)是下行, 和模块的 485 相连, 绿、白(4-9)上行, 转动环用。

The touch screen factory is equipped with an adapter line (inc0702z), J1 is connected to the touch screen serial port, in which the red and blue (7-8) are downlink, connected with the 485 of the module, the green and white (4-9) are uplink, and used for the rotary ring.

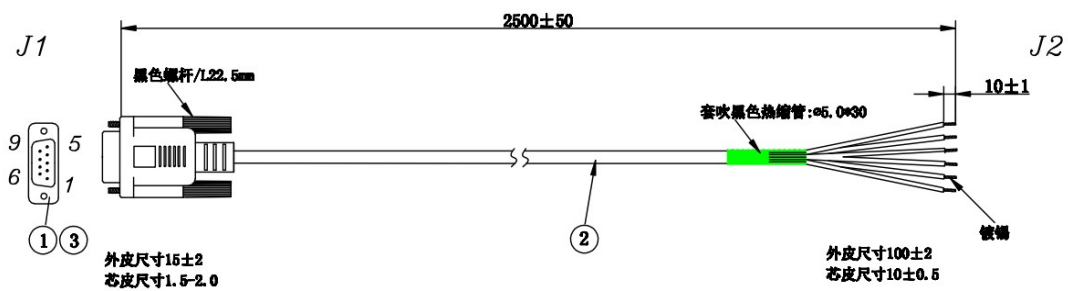
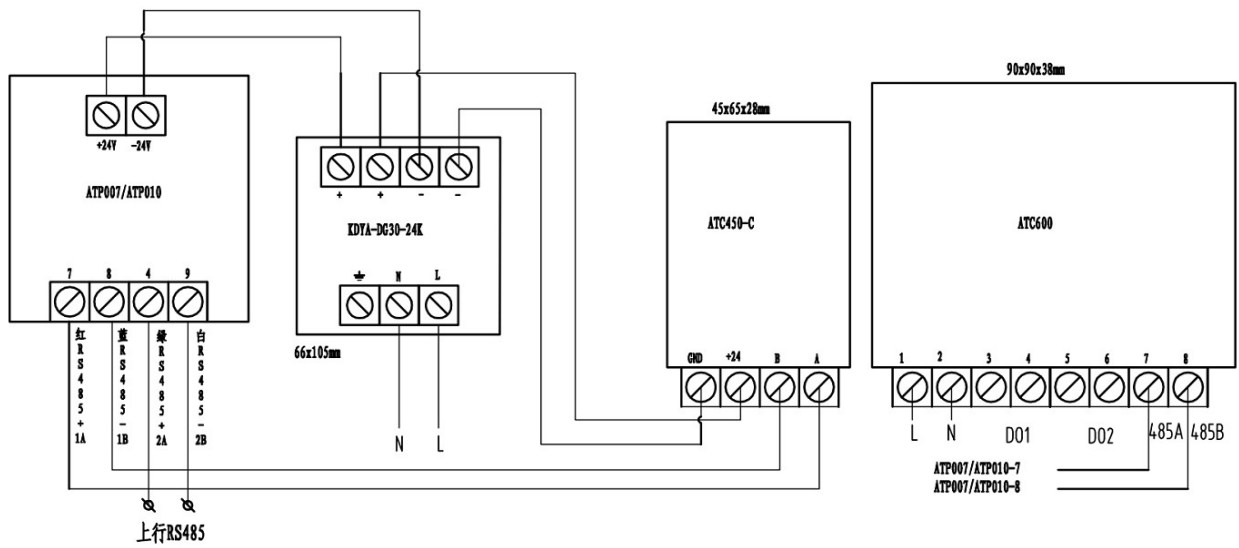

2 产品操作指南

2 Product operation guide

安装好触摸显示屏及无线温度收发器，并连接好两者之间的通讯线缆，然后通过电源转换器给两者接通 DC 24V 的工作电源。

Install the touch screen and wireless temperature transceiver, and connect the communication cable between them, and then connect them with DC 24V working power through the power converter.

2.1 温度显示

2.1 Temperature display

触摸屏上电进入工作状态后，默认即为“实时温度”界面，再此界面可观察到各节点采集的温度值。

After the touch screen is powered on and enters the working state, the default is the "real time temperature" interface, and then the temperature value collected by each point can be monitored on this interface.



图 2.1 实时温度界面

Figure 2.1 real time temperature interface

2.2 定值设置

2.2 Setting value

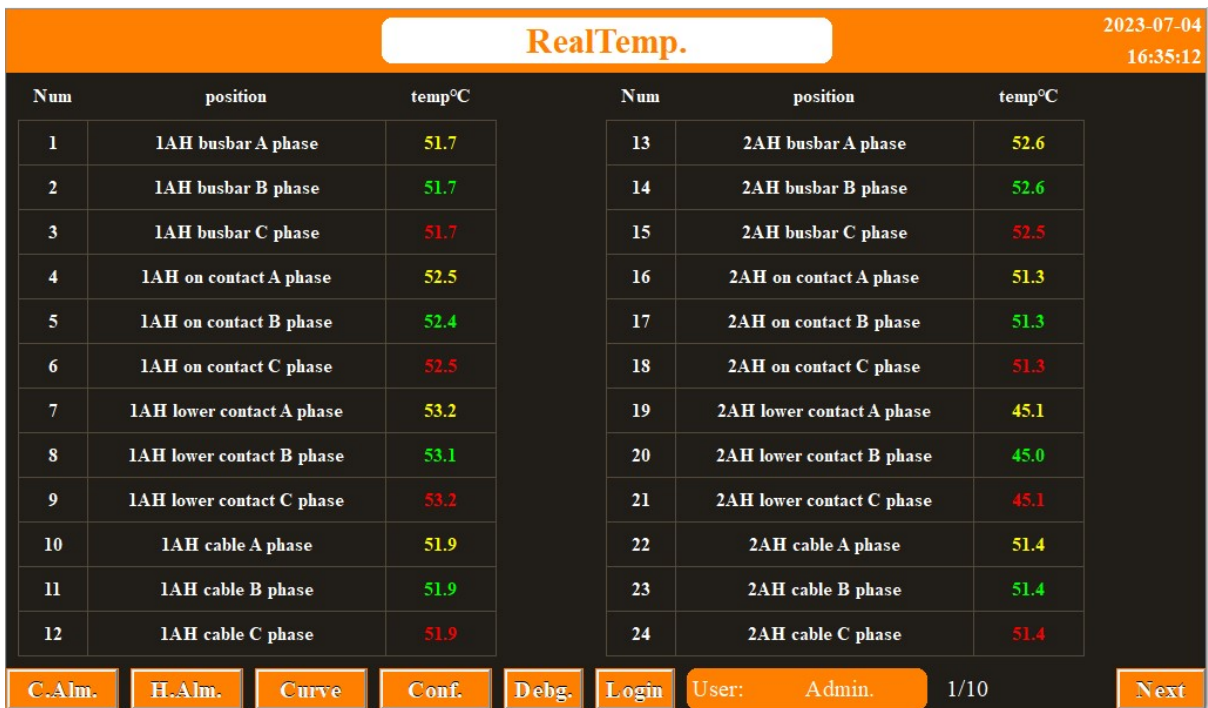
用户“登录”（“用户”默认登录密码为 0008，可通过登录界面修改密码）后，可以通过“参数设置”菜单设置无线温度传感器组的高温告警值和名称，当测得温度值超出设定值时，触摸屏显

示告警并且蜂鸣器鸣叫；同时可以设置中英文语言切换。

节点名称可通过 U 盘导入导出。导入时，需在 U 盘内建立根目录名称为“test”的文件夹；同时在文件夹内建立后缀为“.CSV”的“name”文件。导出时，在文件夹内建立后缀为“.CSV”的name0 文件。

设置好参数之后，一定要点击“保存设置”按钮，否则设置的值不成功。

After the user "logs in" (the default login password of "user" is 0008, and the password can be modified through the login interface), the high temperature alarm value and name of the wireless temperature sensor group can be set through the "parameter setting" menu. When the measured temperature value exceeds the set value, the touch screen will display the alarm and the buzzer will beep, and Chinese and English language switching can be set.

Node names can be imported and exported from a USB flash drive. During import, a folder with the root directory name of "test" needs to be created in the USB flash drive; At the same time, create a "name" file with the suffix ".CSV" in the folder. When exporting, create a "name0" file with the suffi ".CSV" in the folder.

After setting the parameters, be sure to click the "Save Settings" button, otherwise the set value will be lost.



图 2.2 登录管理界面

Figure 2.2 login management interface

参数设置
2023-03-23
15:34:59

节点高温定值设置

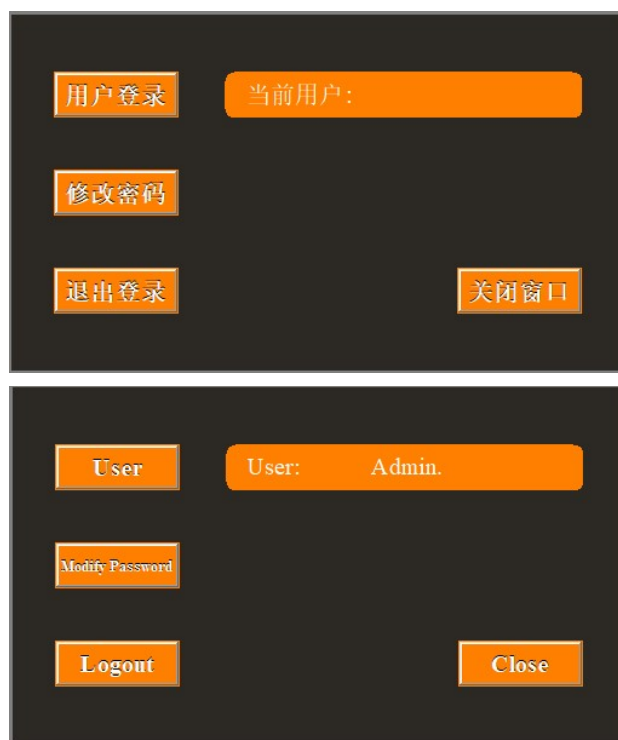
点号	1/2/3	4/5/6	7/8/9	10/11/12	13/14/15	16/17/18	19/20/21	22/23/24	25/26/27	28/29/30
+0	80℃	80℃	80℃	80℃	80℃	80℃	80℃	80℃	80℃	80℃
+30	80℃	80℃	80℃	80℃	80℃	80℃	80℃	80℃	80℃	80℃
+60	80℃	80℃	80℃	80℃	80℃	80℃	80℃	80℃	80℃	80℃
+90	80℃	80℃	80℃	80℃	80℃	80℃	80℃	80℃	80℃	80℃
+120	80℃	80℃	80℃	80℃	80℃	80℃	80℃	80℃	80℃	80℃
+150	80℃	80℃	80℃	80℃	80℃	80℃	80℃	80℃	80℃	80℃
+180	80℃	80℃	80℃	80℃	80℃	80℃	80℃	80℃	80℃	80℃
+210	80℃	80℃	80℃	80℃	80℃	80℃	80℃	80℃	80℃	80℃

设备地址 语言设置 中文

实时温度
1/5
下一页
保存设置

Conf.
2023-03-23
15:35:48

Node high temperature setting

No.	1/2/3	4/5/6	7/8/9	10/11/12	13/14/15	16/17/18	19/20/21	22/23/24	25/26/27	28/29/30
+0	80℃	80℃	80℃	80℃	80℃	80℃	80℃	80℃	80℃	80℃
+30	80℃	80℃	80℃	80℃	80℃	80℃	80℃	80℃	80℃	80℃
+60	80℃	80℃	80℃	80℃	80℃	80℃	80℃	80℃	80℃	80℃
+90	80℃	80℃	80℃	80℃	80℃	80℃	80℃	80℃	80℃	80℃
+120	80℃	80℃	80℃	80℃	80℃	80℃	80℃	80℃	80℃	80℃
+150	80℃	80℃	80℃	80℃	80℃	80℃	80℃	80℃	80℃	80℃
+180	80℃	80℃	80℃	80℃	80℃	80℃	80℃	80℃	80℃	80℃
+210	80℃	80℃	80℃	80℃	80℃	80℃	80℃	80℃	80℃	80℃

Device Addr. Language English

RealTemp.
1/5
Next
Save

图 2.3 参数设置

Figure 2.3 parameter setting



图 2.4 柜名设置

Figure 2.4 Cabinet name setting

2.3 报警信息

2.3 Alarm information

进入“当前报警”界面，显示的是当前告警发生情况，如图 2.4；若要查看所有历史告警，进入“历史报警”界面。在“当前报警”界面查看实时发生的报警，有报警时，此界面显示出报警提示，并且蜂鸣器鸣叫，在蜂鸣器鸣叫时，点击确认报警，蜂鸣器会停止鸣叫，同时报警提示的字颜

色会变为蓝色，当报警故障消除后，报警提示会消失。

Enter the "current alarm" interface to display the current alarm occurrence, as shown in Figure 2.4; to view all historical alarms, enter the "historical alarm" interface. Check the real-time alarm in the "current alarm" interface. When alarming, the interface will display the warning tips and the buzzer will beep. When the buzzer beeps, click to confirm the alarm and the buzzer will stop . At the same time, the color of the warning tips will change to blue. When the alarm fault is removed, the warning tips will disappear.

当前报警 2023-07-04 16:22:13

日期	时间	报警值	报警描述	响应时间
2023/07/04	16:21:59	51.4	024高温	
2023/07/04	16:21:59	51.4	023高温	
2023/07/04	16:21:59	51.4	022高温	
2023/07/04	16:21:59	51.3	018高温	
2023/07/04	16:21:59	51.3	017高温	
2023/07/04	16:21:59	51.3	016高温	
2023/07/04	16:21:59	52.5	015高温	
2023/07/04	16:21:59	52.6	014高温	
2023/07/04	16:21:59	52.6	013高温	
2023/07/04	16:21:59	51.9	012高温	
2023/07/04	16:21:59	51.9	011高温	
2023/07/04	16:21:59	51.9	010高温	
2023/07/04	16:21:59	53.2	009高温	
2023/07/04	16:21:59	53.1	008高温	
2023/07/04	16:21:59	53.2	007高温	

实时温度 历史报警

C.Alm. 2023-07-04 16:22:44

Date	Time	Alarm value	Alarm description	Response time
2023/07/04	16:21:59	51.4	024 High Temp.	
2023/07/04	16:21:59	51.4	023 High Temp.	
2023/07/04	16:21:59	51.4	022 High Temp.	
2023/07/04	16:21:59	51.3	018 High Temp.	
2023/07/04	16:21:59	51.3	017 High Temp.	
2023/07/04	16:21:59	51.3	016 High Temp.	
2023/07/04	16:21:59	52.5	015 High Temp.	
2023/07/04	16:21:59	52.6	014 High Temp.	
2023/07/04	16:21:59	52.6	013 High Temp.	
2023/07/04	16:21:59	51.9	012 High Temp.	
2023/07/04	16:21:59	51.9	011 High Temp.	
2023/07/04	16:21:59	51.9	010 High Temp.	
2023/07/04	16:21:59	53.2	009 High Temp.	
2023/07/04	16:21:59	53.1	008 High Temp.	
2023/07/04	16:21:59	53.2	007 High Temp.	

RealTemp. H.Alm.

图 2.5 当前报警
Figure 2.5 current alarm

2.4 温度曲线

2.4 Temperature curve

进入“温度曲线”界面，每一个页面存有 12 条曲线，共 20 页。每 1 小时记录一次温度，可以存储 100 天。具体曲线要求可在屏上自行调节。输入所需数据的起始时间和结束时间（格式：年-月-日 时-分-秒），U 盘插入，点击“U 盘导出”。当“控制”数值由 0 变为 1 时，说明导出成功。

Enter the "temperature curve" interface, each page has 12 curves, a total of 20 pages. The temperature is recorded every hour and can be stored for 100 days. The specific curve requirements can be adjusted on the screen. Enter the start time and end time of the required data (format: YYYY-MM-DD HOURS-MINUTES-SECONDS), Plug in the USB, and click "USB export". If the Control value changes from 0 to 1, the export is successful.





图 2.5 温度曲线

图 2.5 temperature curve

3 通讯指南

3 Communication Examples

在本章主要讲述如何利用软件通过通讯口来读取无线测温节点温度。本章内容的掌握需要您具有 MODBUS 协议的知识储备并且通读了本册其他章节所有内容，对本产品功能和应用概念有较全面的了解。

In this chapter, we mainly describe how to use software to read the temperature of wireless temperature measurement point through communication port. The master of this chapter requires you to have the knowledge reserve of Modbus protocol and read through all the other chapters of this instructions. You have a comprehensive understanding of the function and application concept of this product.

本章内容包括：通讯应用格式详解，本机的应用细节及参量地址表。

The content of this chapter includes: detailed explanation of communication application format, application details of this machine and parameter address table.

3.1 通讯格式详解

3.1 Detailed communication format

本节所举实例将尽可能的使用如下表所示的格式，数据为十六进制。

The examples in this section will use the format shown in the following table as much as possible, the number is hexadecimal.

3.1.1 读取数据（功能码 04H（只读寄存器）/03H（读写寄存器））

3.1.1 Read State (Function code 04H (Read only register) /03H (Read write register))

此功能允许用户获得设备采集与记录的数据及系统参数。主机一次请求的数据个数没有限制，但不能超出定义的地址范围。

This function allows the user to get the data measured and system parameters recorded by slave. There is no limit of data length for asking data, but it cannot exceed the range of defined address.

例如，主机发送查询数据帧：

For example, master send data frame:

地址 Addr	功能码 Fun	起始地址 Register Addr		寄存器数量 Register Count		CRC16 校验码 CRC 16	
		高 Hi	低 Lo	高 Hi	低 Lo	高 Hi	低 Lo
		01H	03H	00H	30H	00H	03H

装置返回响应数据帧：

Slave answer data frame:

地址 Addr	功能码 Fun	字节数 Byte count	数据 1 Data 1		数据 2 Data 2		数据 3 Data 3		CRC16 校验码 CRC 16	
			高 Hi	低 Lo	高 Hi	低 Lo	高 Hi	低 Lo	高 Hi	低 Lo
			01H	03H	06H	00H	00H	00H	00H	00H

3.1.2 预置单个寄存器（功能码 06H）

3.1.2 Preset Single Register (Function code 06H)

此功能码允许用户改变单个寄存器的内容，可通过此功能码将工作参数写入装置。

User can write active parameter into the single register with this function code.

例如，主机发送：

For example, master send data frame:

地址 Addr	功能码 Fun	寄存器地址 Register Addr		预置值 Value		CRC16 校验码 CRC16	
		高 Hi	低 Lo	高 Hi	低 Lo	高 Hi	低 Lo
		01H	06H	00H	03H	03H	E8H

装置返回响应数据帧：

Slave answer data frame:

地址	功能码	寄存器地址	预置值	CRC16 校验码
----	-----	-------	-----	-----------

Addr	Fun	Register Addr		Value		CRC 16	
		高 Hi	低 Lo	高 Hi	低 Lo	高 Hi	低 Lo
01H	06H	00H	03H	03H	E8H	74H	79H

3.1.3 预置多个寄存器 (功能码 10H)

3.1.3 Preset Multi Registers (Function code 10H)

此功能码允许用户改变多个寄存器的内容，可通过此功能码将工作参数写入装置。

User can write active parameter into the multi registers with this function code.

例如，主机发送：

For example, master send data

地址 Addr	功能码 Fun	起始地址 Register Addr		寄存器数 Register Count		字节数 Byte Count	预置值 1 Value 1		预置值 2 Value 1		CRC16	
		高 Hi	低 Lo	高 Hi	低 Lo		高 Hi	低 Lo	高 Hi	低 Lo	高 Hi	低 Lo
01H	10H	00H	03H	00H	02H	04H	00H	28H	00H	64H	59H	32H

装置返回响应数据帧：

Slave answer data frame:

地址 Addr	功能码 Fun	起始地址 Register Addr		寄存器数量 Register Count		CRC16 校验码 CRC16	
		高字节 Hi	低字节 Lo	高字节 Hi	低字节 Lo	高字节 Hi	低字节 Lo
01H	10H	00H	03H	00H	02H	B1H	C8H

3.2 通讯地址表

3.2 Communication address list

3.2.1 搭配 ATC600-C 地址表

3.2.1 With ATC600-C address table

地址 Addr	参数 Parameter	属性 Attribute	数值范围 Range	数据类型 Data type
0000H	通讯地址 Addr	R/W	001~247	UWord
0001H	预留 Reserved	R		UWord

0002H	告警状态 Alarm status	R	0, 无温度越线; 1, 温度越线告警。 0, No temperature over; 1, Temperature over line alarm.	UWord
0003H	预留 Reserved	R		Word
0004H 00F3H	传感器温度值 Sensor temperature value	R	-50~125(°C), (×10 整数传输), 共 240 个 -50~125(°C)(× 10 integer transmission), 240 in total	Word
00F4H 01E3H	传感器 ID sensor ID	R	每个传感器的 ID 应该不同, 共 240 个 Each sensor ID should be different, 240 in total	UWord
01E4H 01F2H	无线温度传感器 在线状态 Online status of wireless temperature sensor	R	位数据, bit0~bit239 分别对应 1~240 号传感器 在线状态: 0——离线, 1——在线。 Bit data, bit0 ~ bit239 correspond to the online status of sensors 1 ~ 240 respectively; 0 - offline, 1 - online.	UWord
01F3H 0201H	无线温度传感器 电池状态 Wireless temperature sensor battery status	R	位数据, bit0~bit239 分别对应 1~240 号传感器 电池状态: 0——正常, 1——低压。 Bit data, bit0 ~ bit239 correspond to the battery status of sensors 1 ~ 240 respectively; 0 - normal, 1 - low voltage.	UWord
0202H	预留 Reserved	R/W		UWord
0203H 03E3H	预留 Reserved	R		UWord
03E4H 0432H	无线温度传感器高 温定值 Wireless temperature sensor temperature value	R/W	-50~125(°C), 共 80 个(每个定值对应 3 路传感器) -50~125 (°C), a total of 80 (each constant value corresponds to 3 sensors)	Word

3.2.2 搭配 ATC600-M 地址表

3.2.2 With ATC600-M address table

地址 Address	参数 Parameter	属性 Attribute	数值范围 Range	数据类型 Data type
0000H	通讯地址 Add	R/W	1-247, 默认为 1 1-247, Default is 1	UWord
0001H	保留 Reserved	R		UWord
0002H	告警状态 Alarm status	R	1, 无温度越线; 1, 温度越线告警。 0, No temperature over; 1, Temperature over line alarm.	UWord

0003H	保留 Reserve	R		UWord
0004H ~05A3H	1~1440 点温度值 1~1440 points temperature value	R	-40°C ~ 140.0°C (×10);	Word
05A4H ~0693H	无线温度传感器 1~240 号 ID 1~240 Wireless temperature sensor ID	R	1~65534, 65535 表示未绑定传感器 1 ~ 65534 , 65535 means sensor is not bound	UWord
0694H ~06A2H	无线温度传感器 在线状态 Wireless temperature sensor online status	R	位数据, bit0~bit239 分别对应 1~240 号传 感器在线状态; 0——离线, 1——在线。 Bit data, bit0~bit239: 1~240 sensor online status; 0——Offline, 1——online.	UWord
06A3H 0792H	无线温度传感器高 温定值 Wireless temperature sensor temperature value	R/W	-40~140(°C), 共 240 个(每个定值对应 6 路 传感器) -40~140 (°C), a total of 240 (each constant value corresponds to 6 sensors)	Word

注: [1] R—只读; R/W—可读, 可写。

Note: [1] r-read-only; R / w-read-write.

3.3 通讯设置

3.3 Communication settings

如需所有数据传入后台监控系统,则要设置正确的通讯地址,默认通讯地址为 1,波特率为 9600,通讯地址的设定在“参数设置界”面中,在“转发数据地址”输入框内,修改成相应的地址,然后点击“保存设置”,否则掉电后会恢复到默认地址 1。

If you need all the data to be transferred into the background monitoring system, you need to set the correct communication address. The default communication address is 1, and the baud rate is 9600. The communication address is set in the "parameter setting interface". In the "forward data address" input box, modify it to the corresponding address, and then click "Save Settings". Otherwise, it will return to the default address 1 after power failure.

总部：安科瑞电气股份有限公司

Headquarter: Acrel Co., LTD.

地址：上海市嘉定区育绿路 253 号

Address: No.253 Yulv Road Jiading District, Shanghai, China.

电话：0086-21-69158300 0086-21-69156052 0086-21-59156392 0086-21-69156971

TEL.: 0086-21-69158300 0086-21-69156052 0086-21-59156392 0086-21-69156971

传真：0086-21-69158303

Fax: 0086-21-69158303

网址：www.acrel-electric.com

Web-site: www.acrel-electric.com

邮箱：ACREL008@vip.163.com

Email: ACREL008@vip.163.com

邮编：201801

Postcode: 201801

生产基地：江苏安科瑞电器制造有限公司

Manufacturer: Jiangsu Acrel Electrical Manufacturing Co., LTD.

地址：江苏省江阴市南闸街道东盟工业园区东盟路 5 号

Address: No.5 Dongmeng Road Dongmeng Industrial Park, Nanzha Street, Jiangyin

电话（传真）：0086-510-86179970

TEL./Fax: 0086-510-86179970

网址：www.jsacrel.com

Web-site: www.jsacrel.com

邮箱：JY-ACREL001@vip.163.com

Email: JY-ACREL001@vip.163.com

邮编：214405

Postcode: 214405