



EN 61326-1: 2013 EN 61326-2-4:2013

EMC MEASUREMENT AND TEST REPORT
FOR

Applicant : Acrel Co., Ltd.

No.253, Yulv Road, Jiading Dsitriect, Shanghai, China.

Manufacturer : Jiangsu Acrel Electric MFG. Co., Ltd.

No.5, Dongmeng Road, Nanzha Street, Jiangyin City, Jiangsu Province, China.

TEST MODEL: AIL100

Aug.26, 2019

This Report Concerns: <input checked="" type="checkbox"/> Original Report	Equipment Type: Insulation Fault Locator
Test Engineer: <i>Liu Tong</i>	
Test Date: Aug.20, 2019 – Aug.26, 2019	
Reviewed By: <i>Huang Jian</i>	
Approved By: <i>Shangliangdong</i>	
Prepared By:	CHINA CEPREI (SICHUAN) LABORATORY No.45 Wen Ming Dong Road, Longquanyi Chengdu 610100 P. R. China

Note: This report may not be duplicated without prior written consent of China CEPREI (Sichuan) Laboratory.

TABLE OF CONTENTS

GENERAL INFORMATION..... 4

PRODUCT DESCRIPTION FOR EQUIPMENT UNDER TEST (EUT).....4

OBJECTIVE.....4

EQUIPMENT MODIFICATIONS4

1 – EN 61326-1:2013 EN 61326-2-4:2013 5

1.1 CONDUCTED DISTURBANCE AT THE MAINS TERMINALS5

1.1.1 TEST EQUIPMENT LIST AND DETAILS5

1.1.2 DESCRIPTION OF MEASUREMENT CONDITIONS5

1.1.3 LIMITS FOR CONDUCTED DISTURBANCE AT THE MAINS TERMINAL OF CLASS B.....5

1.1.4 TEST PROCEDURE AND THE TEST SET-UP6

SET-UP.....6

1.1.5 VERDICT6

1.2 RADIATED DISTURBANCES.....7

1.2.1 TEST EQUIPMENT LIST AND DETAILS7

1.2.2 DESCRIPTION OF MEASUREMENT CONDITIONS7

1.2.3 LIMITS OF RADIATED DISTURBANCES OF CLASS B AT A MEASURING DISTANCE OF 3M.7

1.2.4 TEST PROCEDURE AND THE TEST SET-UP8

1.2.5 TEST DATA AND RECORDS9

1.2.6 VERDICT9

1.3 HARMONIC CURRENT10

1.3.1 TEST EQUIPMENT LIST AND DETAILS10

1.3.2 DESCRIPTION OF MEASUREMENT CONDITIONS10

1.3.3 TEST PROCEDURE AND THE TEST SET-UP10

1.3.4 VERDICT10

1.4 VOLTAGE CHANGES, VOLTAGE FLUCTUATIONS AND FLICKER.....11

1.4.1 TEST EQUIPMENT LIST AND DETAILS11

1.4.2 DESCRIPTION OF MEASUREMENT CONDITIONS11

1.4.3 TEST PROCEDURE AND THE TEST SET-UP11

1.4. VERDICT11

1.5 ESD.....12

1.5.1 TEST EQUIPMENT LIST AND DETAILS12

1.5.2 DESCRIPTION OF MEASUREMENT CONDITIONS12

1.5.3 C TEST PROCEDURE AND THE TEST SET-UP12

1.5.4 TEST DATA AND RECORDS13

1.5.5 VERDICT13

1.6 EFT/B.....14

1.6.1 TEST EQUIPMENT LIST AND DETAILS14

1.6.2 DESCRIPTION OF MEASUREMENT CONDITIONS14

1.6.3 TEST PROCEDURE AND THE TEST SET-UP14

1.6.4 VERDICT14

1.7 RADIO-FREQUENCY ELECTROMAGNETIC FIELD15

1.7.1 TEST EQUIPMENT LIST AND DETAILS15

1.7.2 DESCRIPTION OF MEASUREMENT CONDITIONS15

1.7.3 TEST PROCEDURE AND THE TEST SET-UP15

1.7.4 TEST DATA AND RECORDS16

1.7.5 VERDICT16

1.8 RADIO-FREQUENCY CONTINUOUS CONDUCTED, 0.15 MHz TO 80 MHz17

1.8.1 TEST EQUIPMENT LIST AND DETAILS17

1.8.2 DESCRIPTION OF MEASUREMENT CONDITIONS17

1.8.3 CONFIGURATION17

1.8.4 TEST DATA AND RECORDS17

1.8.5 VERDICT17

1.9 SURGES.....18

Test model: AIL100

- 1.9.1 TEST EQUIPMENT LIST AND DETAILS18
- 1.9.2 DESCRIPTION OF MEASUREMENT CONDITIONS18
- 1.9.3 TEST PROCEDURE AND THE TEST SET-UP.....18
- 1.9.4 VERDICT19
- 1.10 VOLTAGE DIPS AND INTERRUPTIONS20
- 1.10.1 TEST EQUIPMENT LIST AND DETAILS20
- 1.10.2 DESCRIPTION OF MEASUREMENT CONDITIONS20
- 1.10.3 TEST PROCEDURE AND THE TEST SET-UP20
- 1.10.5 VERDICT20
- APPENDIX – PHOTOGRAPH.....21**

Test model: AIL100

GENERAL INFORMATION

Product Description for Equipment Under Test (EUT)

The product that is produced by **Acrel Co., Ltd.** test model: *AIL100*, the "EUT" as referred to in this report is a **Insulation Fault Locator**, Application model: *AIL100, AIL100-4, AIL100-8, AIL150-4, AIL150-8, AIL200-12*

The applied products insulation fault locator (Model: No.AIL100-4) and insulation fault locator (Model No. AIL100-8) and insulation fault locator (Model No. AIL150-4)and insulation fault locator (Model No. AIL150-8)and insulation fault locator (Model No. AIL200-12)were in same color, and produced from the same structure and manufacturing processes by same suppliers.

Objective

In order to meet the EMC requirements approved by CENELEC, the following standards will be cited:

- 1. EN 61326-1:2013:** Electrical equipment for measurement, control and laboratory use-EMC requirements.
- 2. EN 61326-2-4:2013:** Electrical equipment for measurement, control and laboratory use — EMC requirements Part 2-4: Particular requirements — Test configurations, operational conditions and performance criteria for insulation monitoring devices according to IEC 61557-8 and for equipment for insulation fault location according to IEC 61557-9

The objective of the manufacturer is to demonstrate compliance with the limits for the standard Limits and methods of measurement.

Equipment Modifications

No modification to the EUT was made by China Ceprei (Sichuan) Laboratory to make sure the EUT comply with applicable limits.

Note: The test data is only valid for the test sample. There is possible deviation from the original test data for other products

Test model: AIL100

1 – EN 61326-1:2013 EN 61326-2-4:2013

1.1 Conducted disturbance at the Mains Terminals.

1.1.1 Test Equipment List and Details

Manufacturer	Description	Model	Serial Number	Last Cal. Date	Cal. Period
Albatross Projects GmbH	Shield Room	Site 1	---	2017.10	2 Year
R&S	EMI Test Receiver	ESU40	1302	2018.10	1 Year
R&S	Artificial Mains (Three Line)	ENV4200	1107	2018.02	2 Year
R&S	Artificial Mains (Two Line)	ENV216	3560	2018.02	2 Year
R&S	EMI Test System Cabinet	---	---	N/A	N/A
R&S	EMI Test Software	EMC32	---	N/A	N/A

*Statement of Traceability:

China Ceprei (Sichuan) Laboratory certifies that all calibrations have been performed using suitable standards traceable to the CHINA SCIENTIFIC MEASUREMENT INSTITUTE.

1.1.2 Description of Measurement Conditions

Temperature: 22°C

Humidity: 60%

Pressure: 1033mbar

Electromagnetic environment: normal

1.1.3 Limits for conducted disturbance at the mains terminal of class B.

Frequency range MHz	Limit values dB(μV)	
	Quasi-peak	Average
0.15 to 0.5	66 to 56	56 to 46
0.5 to 5	56	46
5 to 30	60	50

NOTE 1: The lower limit shall apply at the transition frequencies.
NOTE 2: The limit decreases linearly with the frequency in the range 0,15 MHz to 0,50 MHz.

Test model: AIL100

1.1.4 Test procedure and the test set-up

Procedure

- a. The EUT was placed 0.4 meters from the conducting wall of the shielded room with EUT being connected to the power mains through a line impedance stabilization network (LISN). Other support units were connected to the power mains through another LISN. The two LISNs provide 50 Ohm/ 50uH of coupling impedance for the measuring instrument.
- b. Both lines of the power mains connected to the EUT were checked for maximum conducted interference.
- c. The frequency range from 150 kHz to 30 MHz was searched. Emission levels under limit -20dB of the prescribed limits could not be reported.

Set-up

The configuration is in accordance with the requirement in EN61326, the sketch map as follow:

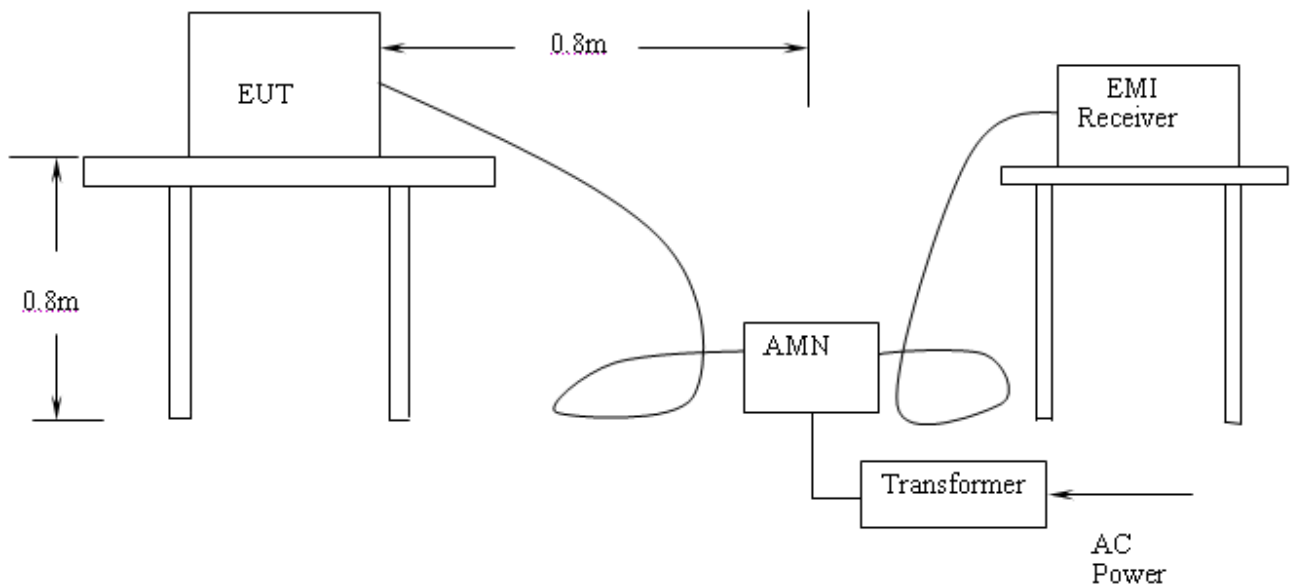

1.1.5 Verdict

This EUT is DC power supply, So it is deemed to fulfil all relevant requirements of this standard without further testing.

Test model: AIL100

1.2 Radiated disturbances

1.2.1 Test Equipment List and Details

Manufacturer	Description	Model	Serial Number	Last Cal. Date	Cal. Period
Albatross Projects GmbH	Anechoic Chamber	---	9290832	2017.10	2 Year
R&S	Ultra-broadband Antennas	HL562	---	2018.01	2 Year
Inn-co GmbH	Antenna Towers	---	---	N/A	N/A
R&S	EMI Test Receiver	ESU40	1302	2018.09	1 Year
Inn-co GmbH	Turntable	DS2000S-1t		N/A	N/A
Inn-co GmbH	Controller	CO 2000	10806L	N/A	N/A
R&S	EMI Test Software	EMC32	---	N/A	N/A
R&S	EMI Test System Cabinet	---	---	N/A	N/A

***Statement of Traceability:**

China Ceprei (Sichuan) Laboratory certifies that all calibrations have been performed using suitable standards traceable to the CHINA SCIENTIFIC MEASUREMENT INSTITUTE.

1.2.2 Description of Measurement Conditions

Temperature: 24°C

Humidity: 60%

Pressure: 1033mbar

Electromagnetic environment: normal

1.2.3 Limits of radiated disturbances of class B at a measuring distance of 3m.

Frequency range MHz	Quasi-peak limits dB(µV/m)
30 to 230	40
230 to 1000	47

NOTE: The lower limit shall apply at the transition frequency.

NOTE: Additional provisions may be required for cases where interference occurs.

Test model: AIL100

1.2.4 Test procedure and the test set-up

Procedure

The EUT was placed on the top of a rotating table 0.8 meters above the ground at a 3m semi/full-anechoic chamber. The table was rotated 360 degrees to determine the position of the highest radiation.

- b. The EUT was set 3 meters away from the interference-receiving antenna, which was mounted on the top of a variable-height antenna tower.
- c. The antenna is a broadband antenna, and its height is varied from one meter to four meters above the ground to determine the maximum value of the field strength. Both horizontal and vertical polarization of the antenna are set to make the measurement.
- d. For each suspected emission, the EUT was arranged to its worst case and then the antenna was tuned to heights from 1 meter to 4 meters and the turn table was turned from 0 degrees to 360 degrees to find the maximum reading.
- e. The test-receiver system was set to Peak Detect Function and Specified Bandwidth with Maximum Hold Mode.
- f. If the emission level of the EUT in peak mode was 10 dB lower than the limit specified, then testing could be stopped and the peak values of the EUT would be reported. Otherwise the emissions that did not have 10 dB margin would be retested one by one using the quasi- peak method or average method as specified and then reported In Data sheet peak mode and QP mode.

Set-up

The configuration is in accordance with the requirement in EN61326, the sketch map as follow:

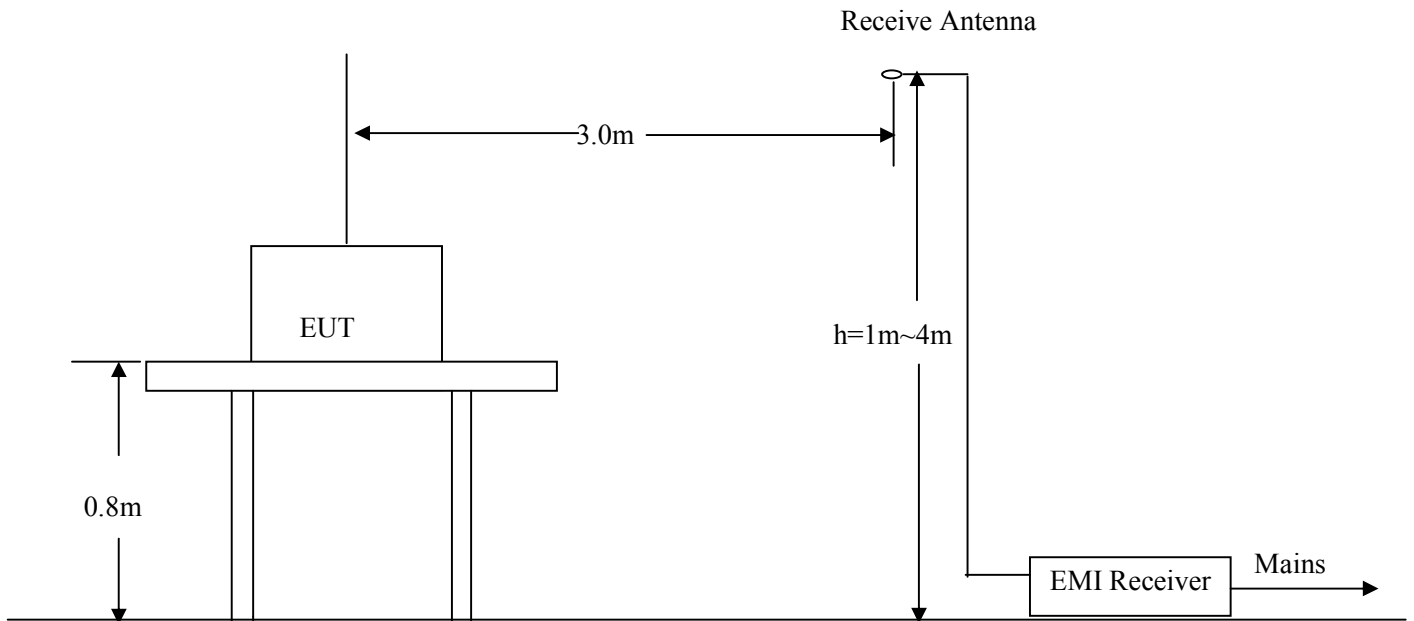

Test model: AIL100

1.2.5 Test Data and Records Passed

Vertical :

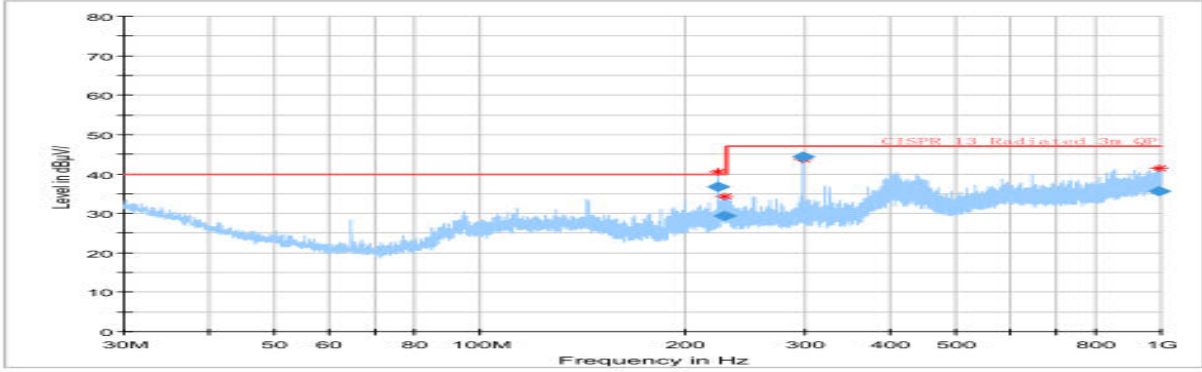

Horizontal :

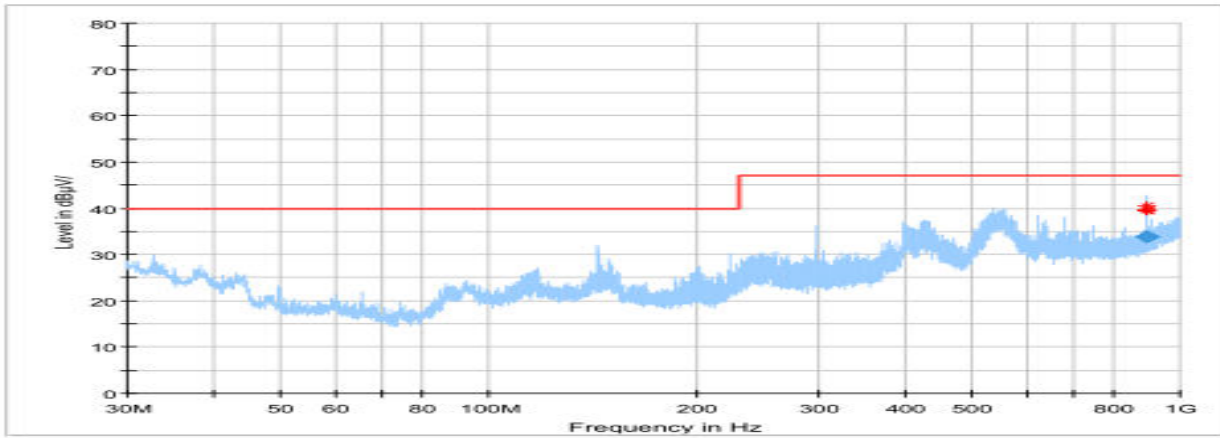

1.2.6 Verdict

The EUT met the requirement.

Test model: AIL100

1.3 Harmonic current

1.3.1 Test Equipment List and Details

Manufacturer	Description	Model	Serial Number	Last Cal. Date	Cal. Period
EMC-PARTNER	Harmonics and Flicker Analyzer	HARMONIC S-1000	HAR1000-40	2017.07	3 Year

***Statement of Traceability:**

China Ceprei (Sichuan) Laboratory certifies that all calibrations have been performed using suitable standards traceable to the CHINA SCIENTIFIC MEASUREMENT INSTITUTE.

1.3.2 Description of Measurement Conditions

Temperature: 22°C
Humidity: 56%
Pressure: 1033mbar
Electromagnetic environment: normal

1.3.3 Test procedure and the test set-up

Procedure

- a. The EUT was placed on the top of a wooden table 0.8 meters above the ground and operated to produce the maximum harmonic components under normal operating conditions for each successive harmonic component in turn.
- b. The classification of EUT is according to section 5 of EN 61000-3-2. The EUT is classified as follows:
 - Class A: Balanced three-phase equipment, Household appliances excluding equipment as Class D, Tools excluding portable tools, Dimmers for incandescent lamps, audio equipment, equipment not specified in one of the three other classes.
 - Class B: Portable tools. Arc welding equipment which is not professional equipment
 - Class C: Lighting equipment, including dimming devices.
 - Class D: Equipment having a specified power less than or equal to 600 W of the following types: Personal computers and personal computer monitors.
- c. The correspondent test program of test instrument to measure the current harmonics emanated from EUT is chosen. The measure time shall be not less than the time necessary for the EUT to be exercised.

Set-up

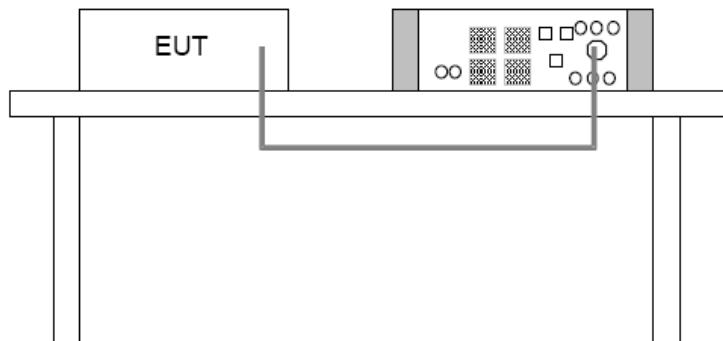

1.3.4 Verdict

This EUT is DC power supply, So it is deemed to fulfil all relevant requirements of this standard without further testing.

Test model: AIL100

1.4 Voltage changes, voltage fluctuations and flicker

1.4.1 Test Equipment List and Details

Manufacturer	Description	Model	Serial Number	Last Cal. Date	Cal. Period
EMC-PARTNER	Harmonics and Flicker Analyzer	HARMONIC S-1000	HAR1000-40	2017.07	3 Year

*Statement of Traceability:

China Ceprei (Sichuan) Laboratory certifies that all calibrations have been performed using suitable standards traceable to the CHINA SCIENTIFIC MEASUREMENT INSTITUTE.

1.4.2 Description of Measurement Conditions

Temperature: 21°C

Humidity: 58%

Pressure: 1033mbar

Electromagnetic environment: normal

1.4.3 Test procedure and the test set-up

Procedure

- The EUT was placed on the top of a wooden table 0.8 meters above the ground and operated to produce the most unfavorable sequence of voltage changes under normal operating conditions.
- During the flick measurement, the measure time shall include that part of whole operation cycle in which the EUT produce the most unfavorable sequence of voltage changes. The observation period for short-term flicker indicator is 10 minutes and the observation period for long-term flicker indicator is 2 hours.

Set-up

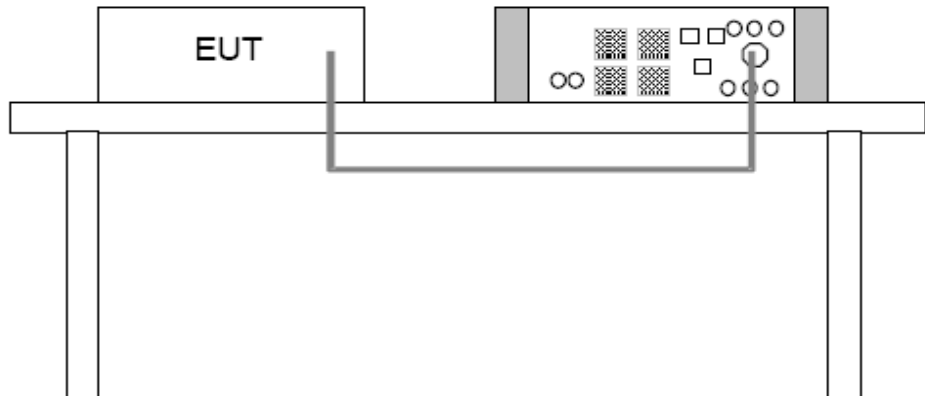

1.4. Verdict

This EUT is DC power supply, So it is deemed to fulfil all relevant requirements of this standard without further testing.

Test model: AIL100

1.5 ESD

1.5.1 Test Equipment List and Details

Manufacturer	Description	Model	Serial Number	Last Cal. Date	Cal. Period
Shanghai Sanki	Electrostatic Discharge tester	ESD-320	0329501C	2018.06	2 Year

***Statement of Traceability:**

China Ceprei (Sichuan) Laboratory certifies that all calibrations have been performed using suitable standards traceable to the CHINA SCIENTIFIC MEASUREMENT INSTITUTE.

1.5.2 Description of Measurement Conditions

Temperature: 23°C

Humidity: 60%

Pressure: 1033mbar

Electromagnetic environment: normal

1.5.3 C Test procedure and the test set-up

Procedure

- a. Electrostatic discharges were applied only to those points and surfaces of the EUT that are accessible to users during normal operation.
- b. The test was performed with at least ten single discharges on the pre-selected points in the most sensitive polarity.
- c. The time interval between two successive single discharges was at least 1 second.
- d. The ESD generator was held perpendicularly to the surface to which the discharge was applied and the return cable was at least 0.2 meters from the EUT.
- e. Contact discharges were applied to the non-insulating coating, with the pointed tip of the generator penetrating the coating and contacting the conducting substrate.
- f. Air discharges were applied with the round discharge tip of the discharge electrode approaching the EUT as fast as possible (without causing mechanical damage) to touch the EUT. After each discharge, the ESD generator was removed from the EUT and re-triggered for a new single discharge. The test was repeated until all discharges were complete.
- g. At least ten single discharges (in the most sensitive polarity) were applied at the front edge of each Horizontal Coupling Plane opposite the center point of each unit of the EUT and 0.1 meters from the front of the EUT. The long axis of the discharge electrode was in the plane of the HCP and perpendicular to its front edge during the discharge.
- h. At least ten single discharges (in the most sensitive polarity) were applied to the center of one vertical edge of the Vertical Coupling Plane in sufficiently different positions that the four faces of the EUT were completely illuminated. The VCP (dimensions 0.5m x 0.5m) was placed vertically to and 0.1 meters from the EUT.

Test model: AIL100

Set-up

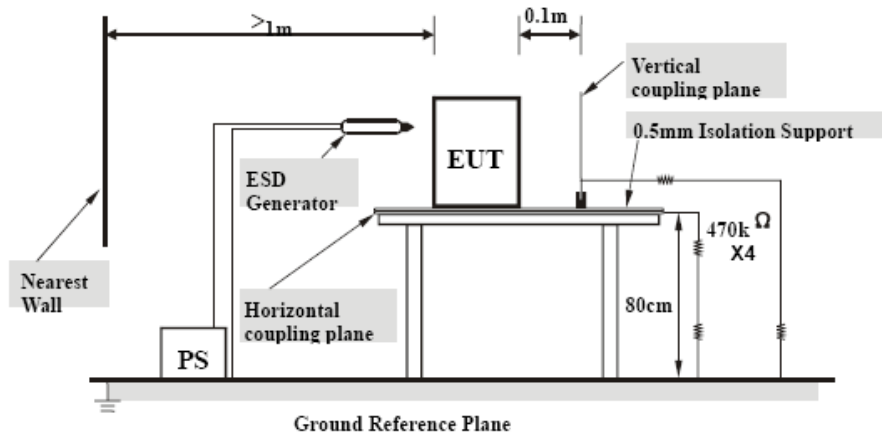

1.5.4 Test Data and Records

Air Discharge

Test Levels																
EN61000-4-2 Test Points	-2 kV	+2 kV	-4 kV	+4 kV	-6 kV	+6 kV	-8 kV	+8 kV	-10 kV	+10 kV	-12.5 kV	+12.5 kV	-15 kV	+15 kV	-20 kV	+20 kV
EUT Front Side	B	B	B	B	B	B	B	B								
EUT Top Side	B	B	B	B	B	B	B	B								
EUT Back Side	B	B	B	B	B	B	B	B								
EUT Left Side	B	B	B	B	B	B	B	B								
EUT Right Side	B	B	B	B	B	B	B	B								

Direct Contact

Test Levels																
EN61000-4-2 Test Points	-2 kV	+2 kV	-4 kV	+4 kV	-6 kV	+6 kV	-8 kV	+8 kV	-10 kV	+10 kV	-12.5 kV	+12.5 kV	-15 kV	+15 kV	-20 kV	+20 kV
EUT Front Side	B	B	B	B												
EUT Top Side	B	B	B	B												
EUT Back Side	B	B	B	B												
EUT Left Side	B	B	B	B												
EUT Right Side	B	B	B	B												

1.5.5 Verdict

The EUT was working as normal, so it met the requirement of performance criteria B.

Test model: AIL100

1.6 EFT/B

1.6.1 Test Equipment List and Details

Manufacturer	Description	Model	Serial Number	Last Cal. Date	Cal. Period
Shanghai Sanki	E.F.TB Generator	8014	069504E	2018.06	2 Year

*Statement of Traceability:

China Ceprei (Sichuan) Laboratory certifies that all calibrations have been performed using suitable standards traceable to the CHINA SCIENTIFIC MEASUREMENT INSTITUTE.

1.6.2 Description of Measurement Conditions

Temperature: 20°C

Humidity: 60%

Pressure: 1033mbar

Electromagnetic environment: normal

1.6.3 Test procedure and the test set-up

Procedure

- Both positive and negative polarity discharges were applied.
- The length of the “hot wire” from the coaxial output of the EFT generator to the terminals on the EUT should not exceed 1 meter.
- The duration time of each test sequential was 1 minute.
- The transient/burst waveform was in accordance with IEC 61000-4-4, 5/50ns.

Set-up

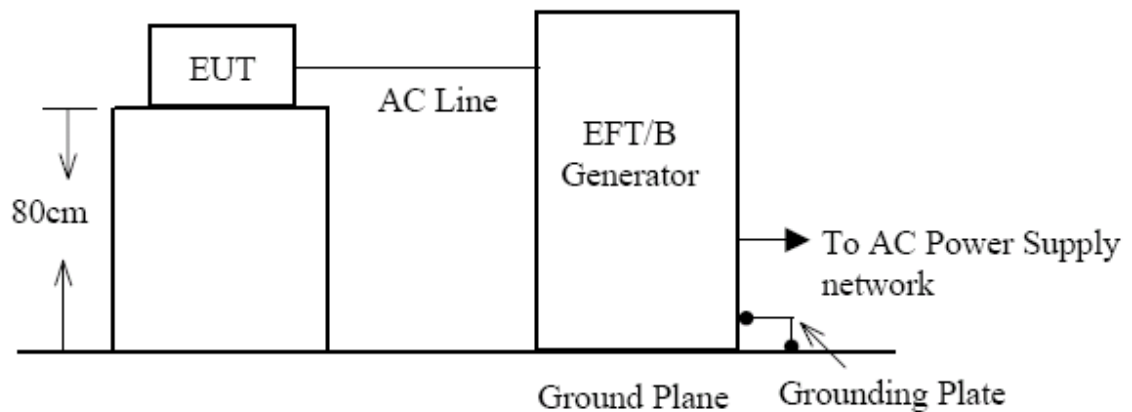

1.6.4 Verdict

This EUT is DC power supply, So it is deemed to fulfil all relevant requirements of this standard without further testing.

Test model: AIL100

1.7 Radio-frequency electromagnetic field

1.7.1 Test Equipment List and Details

Manufacturer	Description	Model	Serial Number	Last Cal. Date	Cal. Period
R&S	Signal Generator	SMR-40	1104	2018.09	1 Year
QF	Broadband Power Amplifier	QF3860	---	2018.02	2 Year
QF	Millivoltmeter	QF2281	92028	2018.02	2 Year
Albatross Projects GmbH	Anechoic Chamber	---	9290832	2017.10	2 Year
R&S	Ultra-broadband Antennas	HL562	---	2018.01	2 Year
Inn-co GmbH	Antenna Towers	---	---	N/A	N/A
Inn-co GmbH	Turntable	DS2000S-1t	---	N/A	N/A
Inn-co GmbH	Controller	CO 2000	10806L	N/A	N/A
R&S	EMI Test Software	EMC32	---	N/A	N/A
R&S	EMI Test System Cabinet	---	---	N/A	N/A

*Statement of Traceability:

China Ceprei (Sichuan) Laboratory certifies that all calibrations have been performed using suitable standards traceable to the CHINA SCIENTIFIC MEASUREMENT INSTITUTE.

1.7.2 Description of Measurement Conditions

Temperature: 20°C

Humidity: 60%

Pressure: 1033mbar

Electromagnetic environment: normal

1.7.3 Test procedure and the test set-up

Procedure

The test procedure was in accordance with EN 61000-4-3

- The testing was performed in a fully-anechoic chamber. The transmit antenna was located at a distance of 3 meters from the EUT.
- The frequency range is swept from 80 MHz to 1000 MHz with the signal 80% amplitude modulated with a 1kHz sine wave. The rate of sweep did not exceed 1.5×10^{-3} decade/s. Where the frequency range is swept incrementally, the step size was 1 % of preceding frequency value.
- The dwell time at each frequency shall be not less than the time necessary for the EUT to be able to respond.
- The field strength level was 3V/m or 1V/m.
- The test was performed with the EUT exposed to both vertically and horizontally polarized fields on each of the four sides.

Test model: AIL100

Set-up

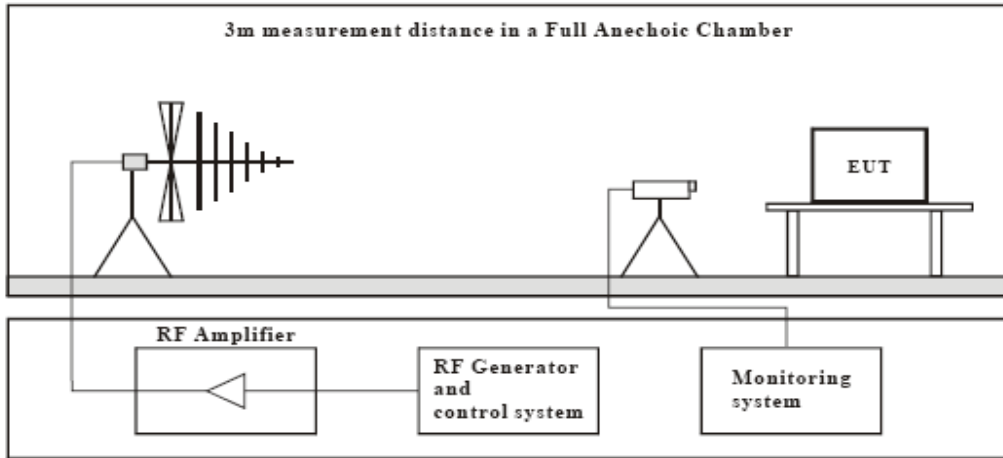

1.7.4 Test Data and Records

Frequency Range (MHz)	Front Side (10V/m)		Rear Side (10 V/m)		Left Side (10 V/m)		Right Side (10 V/m)	
	VERT	HORI	VERT	HORI	VERT	HORI	VERT	HORI
80-1000	A	A	A	A	A	A	A	A

1.7.5 Verdict

The EUT was working as normal, so it met the requirement of performance criteria A.

Test model: AIL100

1.8 Radio-frequency continuous conducted, 0.15 MHz to 80 MHz

1.8.1 Test Equipment List and Details

Manufacturer	Description	Model	Serial Number	Last Cal. Date	Cal. Period
Giga-tronics	Synthesized RF Signal Generator	6061A	5130304	2018.02	2 Year
QF	Broadband Power Amplifier	QF3860	---	2018.02	2 Year
QF	Millivoltmeter	QF2281	92028	2018.02	2 Year

*Statement of Traceability:

China Ceprei (Sichuan) Laboratory certifies that all calibrations have been performed using suitable standards traceable to the CHINA SCIENTIFIC MEASUREMENT INSTITUTE.

1.8.2 Description of Measurement Conditions

Temperature: 20°C
Humidity: 60%
Pressure: 1033mbar
Electromagnetic environment: normal

1.8.3 Configuration

The configuration in accordance with the requirement in EN61000-4-6, see the photo in appendix.

1.8.4 Test Data and Records

The EUT was tested that it worked at the normal state.

EN61000-4-6 Test Points	Frequency range MHz	Levels	Voltage Level (e.m.f.)V	Pass	Fail
0.15-80 (power port)	0.15-80MHz	1	1		
		2	3	A	
		3	10		
		X	Special		

1.8.5 Verdict

The EUT was working as normal, so it met the requirement of performance criteria A.

Test model: AIL100

1.9 SURGES

1.9.1 Test Equipment List and Details

Manufacturer	Description	Model	Serial Number	Last Cal. Date	Cal. Period
Noise Laboratory CO., LTD	Surge Lite	LSS-6030	9099E00350	2017.11	2 Year

*Statement of Traceability:

China Ceprei (Sichuan) Laboratory certifies that all calibrations have been performed using suitable standards traceable to the CHINA SCIENTIFIC MEASUREMENT INSTITUTE.

1.9.2 Description of Measurement Conditions

Temperature: 21 °C
Humidity: 58%
Pressure: 1033mbar
Electromagnetic environment: normal

1.9.3 test procedure and the test set-up

Procedure

- a. For EUT power supply:
The surge is to be applied to the EUT power supply terminals via the capacitive coupling network. Decoupling networks are required in order to avoid possible adverse effects on equipment not under test that may be powered by the same lines, and to provide sufficient decoupling impedance to the surge wave. The power cord between the EUT and the coupling/decoupling networks shall be 2 meters in length (or shorter).
- b. For test applied to unshielded unsymmetrically operated interconnection lines of EUT: The surge is applied to the lines via the capacitive coupling. The coupling / decoupling networks shall not influence the specified functional conditions of the EUT. The interconnection line between the EUT and the coupling/decoupling networks shall be 2 meters in length (or shorter).
- c. For test applied to unshielded symmetrically operated interconnection / telecommunication lines of EUT: The surge is applied to the lines via gas arrestors coupling. Test levels below the ignition point of the coupling arrestor cannot be specified. The interconnection line between the EUT and the coupling/decoupling networks shall be 2 meters in length (or shorter).
- a. Both positive and negative polarity discharges were applied.
- b. The length of the “hot wire” from the coaxial output of the EFT generator to the terminals on the EUT should not exceed 1 meter.
- c. The duration time of each test sequential was 1 minute.
- d. The transient/burst waveform was in accordance with IEC 61000-4-4, 5/50ns.

Set-up

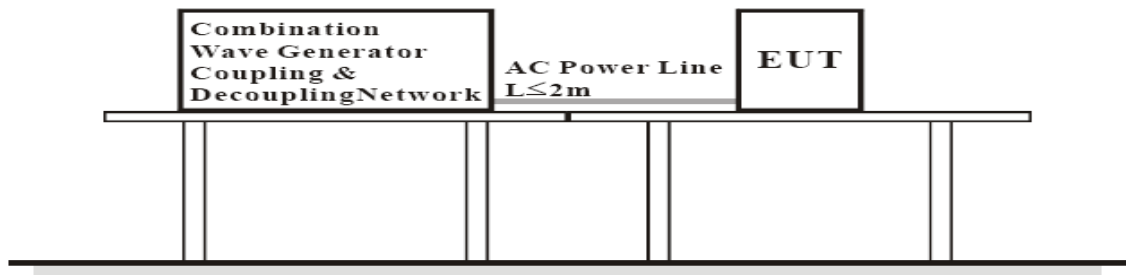

Test model: AIL100

1.9.4 Verdict

This EUT is DC power supply, So it is deemed to fulfil all relevant requirements of this standard without further testing.

Test model: AIL100

1.10 VOLTAGE DIPS AND INTERRUPTIONS

1.10.1 Test Equipment List and Details

Manufacturer	Description	Model	Serial Number	Last Cal. Date	Cal. Period
Noise Laboratory CO., LTD	Voltage Dip Simulator	VDS-220B	2199D00098	2017.10	2 Year

***Statement of Traceability:**

China Ceprei (Sichuan) Laboratory certifies that all calibrations have been performed using suitable standards traceable to the CHINA SCIENTIFIC MEASUREMENT INSTITUTE.

1.10.2 Description of Measurement Conditions

Temperature: 21 °C
Humidity: 58%
Pressure: 1033mbar
Electromagnetic environment: normal

1.10.3 Test procedure and the test set-up

Procedure

The EUT shall be tested for each selected combination of test levels and duration with a sequence of three dips/interruptions with intervals of 10 s minimum (between each test event). Each representative mode of operation shall be tested. Abrupt changes in supply voltage shall occur at zero crossings of the voltage waveform.

Set-up

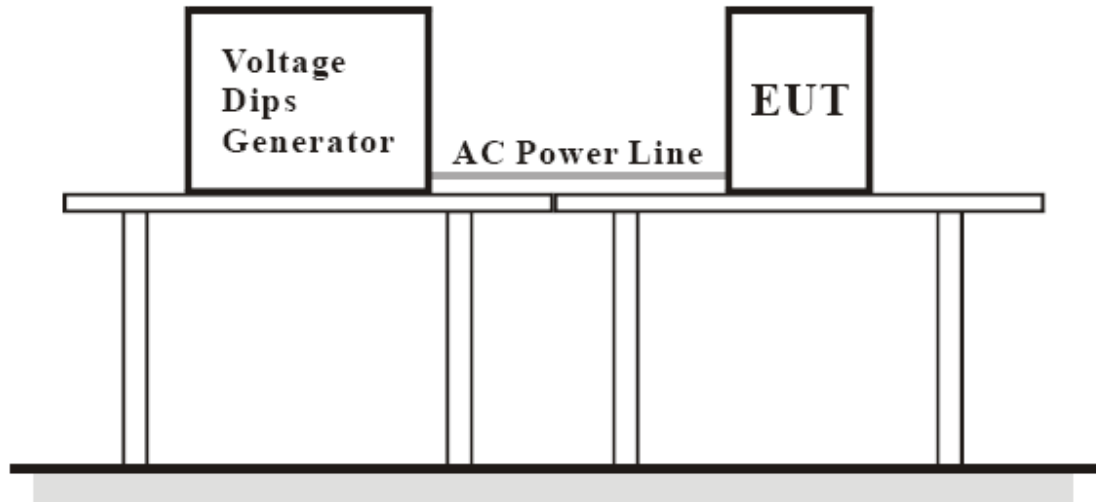

1.10.5 Verdict

This EUT is DC power supply, So it is deemed to fulfil all relevant requirements of this standard without further testing.

APPENDIX – PHOTOGRAPH



Notice

1. This test report shall be invalidation without the cachet of the testing laboratory.
2. This copied report shall be invalidation without sealed the cachet of the testing laboratory.
3. This report shall be invalidation without tester signature, reviewer signature and approver signature.
4. This altered report shall be invalidation.
5. Client shall put forward demurrer within 15days after received report. The testing laboratory shall refuse disposal if exceeded the time limit.
6. The test results presented in this report relate only to the object tested.