



高品质定制产品系列

- **设计**—造型严谨，注重每个线条的细节，由内而外的气质体现；

- **材料**—高端、环保、天然；

- **品质**—标准化开发模式，成熟结构连接，进口品质要求；

- **产品**—经过市场检验的畅销款；

- **DESIGN**—Modelling, infinite close to the original, from the inside and out of the temperament.

- **MATERIAL**: Environmental, protection natural, Quality;

- **QUALITY**: Standardized development mode, mature structural connection; import quality requirements;

- **FURNITURE**: After the market test of the best-selling;



# 面料篇

## F A B R I C

Italily 面料分为三个等级：可接受客供面料，以一等级面料报价

**一等级：**以棉麻面料为主，纱线材质丰富，色彩高级，层次感强，克重及耐磨测试高；

**二等级：**天鹅绒面料，天然成分高，色彩饱满；

超纤皮，颜色自然，物理性能稳定，性价比高

**三等级：**含羊毛、绒成分，手感舒适，天然成分，刚使用中有轻微起毛现象。

MAYER LARGE Art Mayer



Categoria / Category  
11

Composizione / Composition  
33% Acrilico / Acrylic  
29% Cotone / Cotton  
21% Viscosa / Viscosa  
5% Lino / Linen  
8% Poliestere / Polyester

Indicazioni di lavaggio / Washing instructions  
[Icons: Machine wash, No bleach, No iron, No dry clean, No tumble dry]



FISHER Art 31

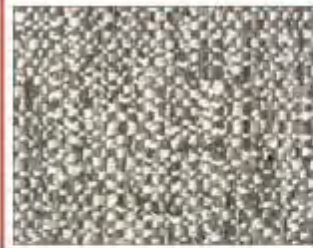

Categoria / Category  
0

Composizione / Composition  
57% Polipropilene / Polypropylene  
21% Acrilico / Acrylic  
17% Polipropilene / Polypropylene  
1% Lino / Linen  
1% Lana / Wool  
4% Cotone / Cotton  
1% Polipropilene / Polypropylene

Indicazioni di lavaggio / Washing instructions  
[Icons: Machine wash, No bleach, No iron, No dry clean, No tumble dry]

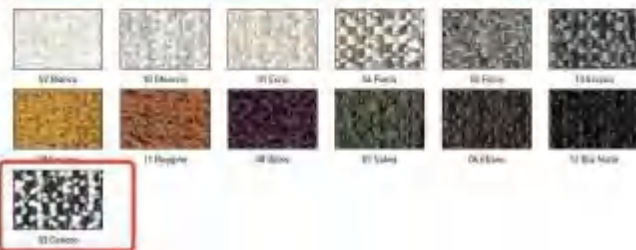

## 木 材 篇

### W O O D

ITALILY 产品中木质部分主要由两种材料部件构成：木皮贴面和实木，根据产品形态、气质及稳定性需求综合应用。

木皮贴面的基材采用P2级中纤板或铝材、塑木复合板等，亦根据具体产品的特性及需求选择性应用。

The wood part of Italily products is mainly composed of two materials; Wood veneer and solid wood, according to the product form, temperament and stability requirements integrated application.

The substrate of veneer veneer is P2 MDF, aluminum, plastic wood composite board, etc., which can be selectively applied according to the characteristics and needs of specific products.

- **白栓直纹实木木皮：**产地美国 纹理细腻，线条整齐内敛
- **白橡木山纹实木木皮：**产地欧洲 可做染色木皮，纹理大气丰富，适合做桌几表面木皮
- **鲍迪豆实木 木皮：**产地南美洲 颜色丰富，层次多，适合做装饰木皮

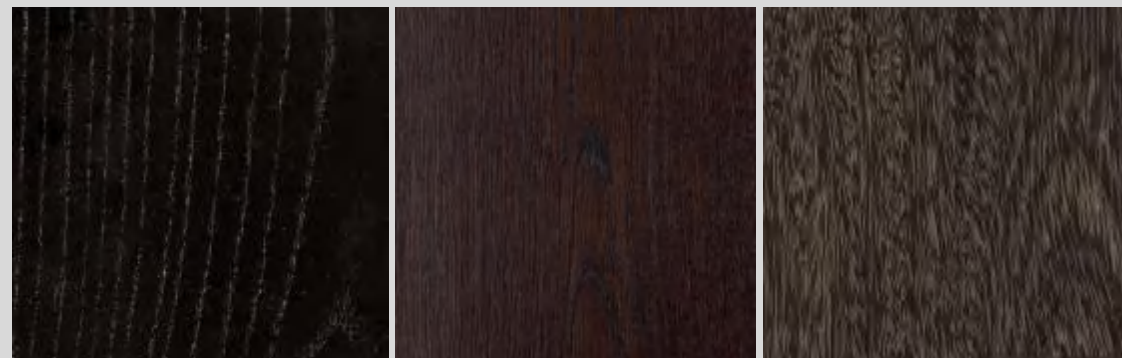

## 皮料篇

### LEATHER

Italily 牛皮分为三个等级：全部是意大利进口牛皮

**一等级：**平纹Napa皮，适合做硬体家具外包部分皮料；

**二等级：**荔枝纹意大利进口皮，木桶浸染工艺，色彩饱和度高，皮胚皮质完整，弹性适中，肉感舒适，适合做模块大沙发，厚度1.4~1.8。

**三等级：**进口磨砂皮，目前只用于minotti大屏床，由于磨砂皮的天然属性难维护，表面不做修饰，脖颈纹相对明显，价格高，不建议用于大沙发。



# 内部结构

STRUCTURE

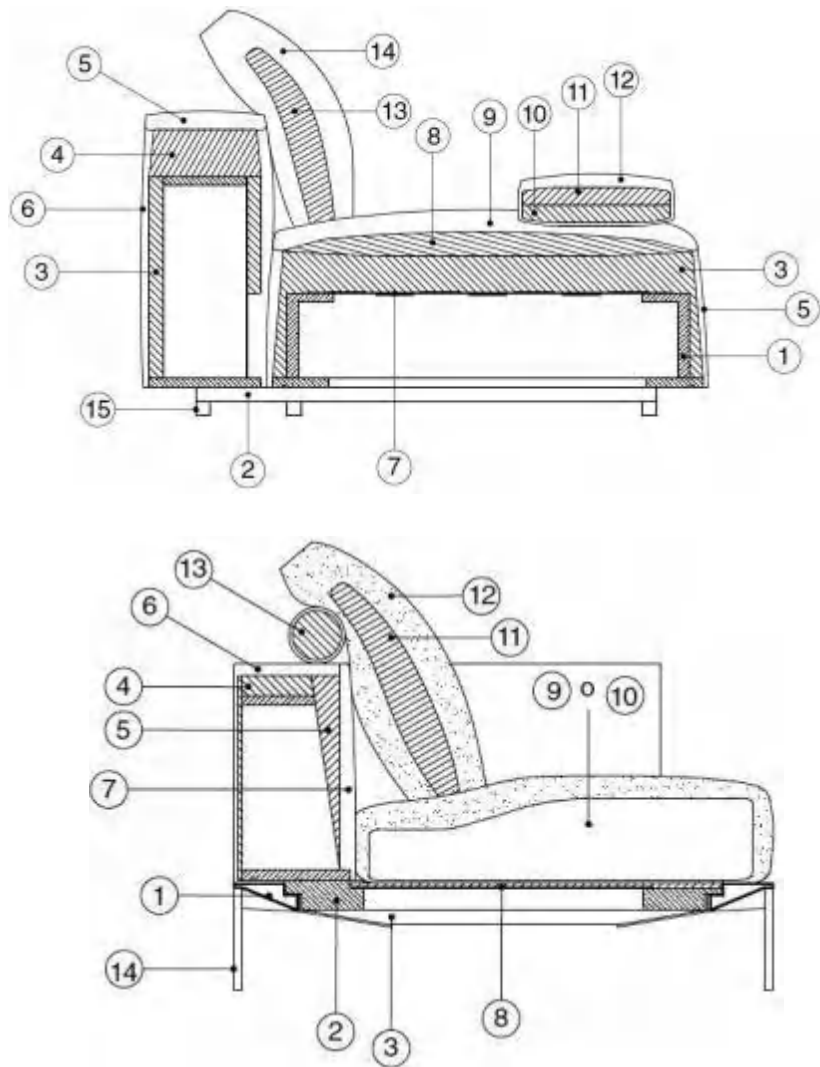

不同的款型，根据设计造型及人体工程学原理，搭配不同的材料和拼接方法，让家具更科学，美观



让每一个精致、舒适的产品，具备独一无二的设计

每一个细节都是有原因的，全为精心制作

Let each exquisite, comfortable products, with a unique design.

Every detail is for a reason. It's all crafted.

# 模块沙发 - “Modular sofa”

Technical Features



北极熊



CONNERY系列



SAINT-GERMAIN系列

PZ-22系列

# 三人沙发 - “Three-seat sofa” Mix

Technical Features



L-03L系列



L-01系列



L-04L系列





# 三人沙发 - “Three-seat sofa” Mix

Technical Features



# 单人沙发 - “Single sofa”

Technical Features



# 单人沙发 - "Single sofa"

Technical Features



# 单人沙发 - “Single sofa”

Technical Features



# 茶几 - “Coffee table” Mix

Technical Features



# 茶几 - "Coffee table" Mix

Technical Features



# 餐桌 - “Dining table” Mix

Technical Features



# 餐椅 - “Dining chair” Mix

Technical Features





# 餐椅 - “Dining chair” Mix

Technical Features



# 餐椅 - “Dining chair” Mix

Technical Features



# 床 - "Bed" Mix

Technical Features

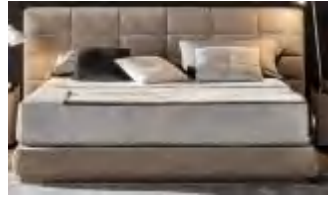

瑞卡

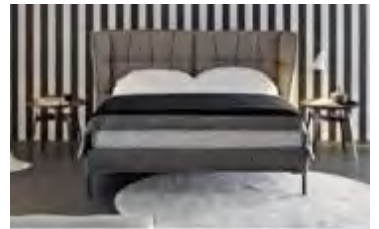

# 床头柜 - “Night Table”Mix

Technical Features

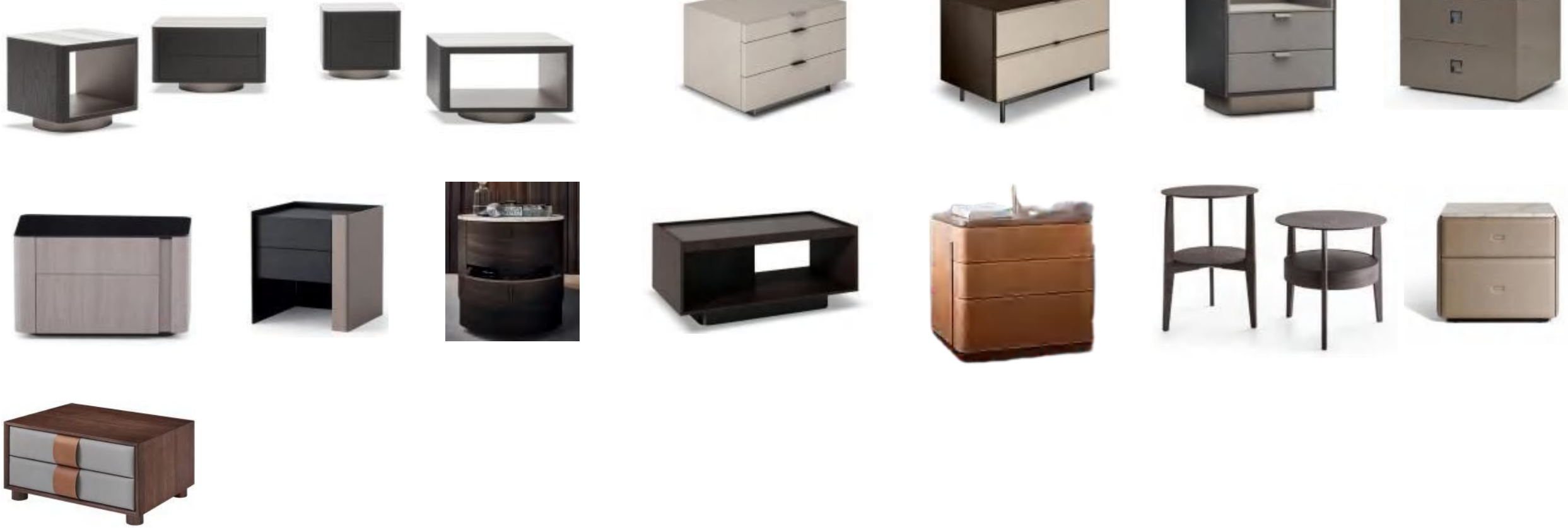

# 边柜 - “Side Table” Mix

Technical Features



沙发背几



# 书桌 - “Writing Desk” Mix

Technical Features

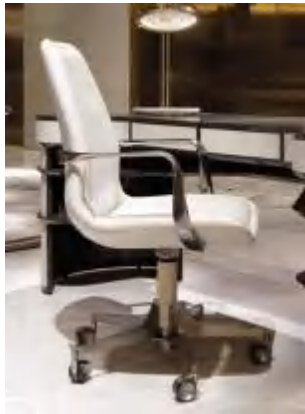
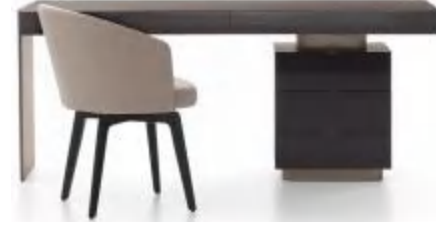

多款模块化组件可以创造出多种多样的组合形式,从具有完美几何造型的“L”型方案到线条轻巧的线性演绎方案,皆能应对自如, 这要得益于独具创意的A001-M弧形组件, 比如

躺椅或其他圆角末端沙发。

产品拥有高低不一的靠背, 亦可将其组合搭配, 增强这一系

列的多用性。U字型的高靠背设计打造出一处私密的角落, 让人可以在这一空间中舒适地阅读或看电视。此外,低靠背设计的组件则不会遮蔽周围空间的视野。



金属饰面  
MATERIAL

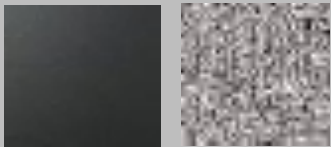

黑色哑光漆 MY-A2842-1A

模块沙发,可根据实际摆放面积,自由组合不同模块,腿部喷涂黑色哑光漆,面料可选皮或者布。



场景图片

SPACE PICTURE





实物细节照片  
DETAIL PICTURE



实物拍摄  
材质：MY-A2842  
-1A 金棕色  
金属脚 尺寸见  
下图

常用组合  
ARRANGEMENTS





常用组合  
ARRANGEMENTS



# 可选模块尺寸

## Technical Features

ELEMENTO TERMINALE **LOW CM 152**  
ELEMENT WITH ONE ARMREST **LOW CM 152**

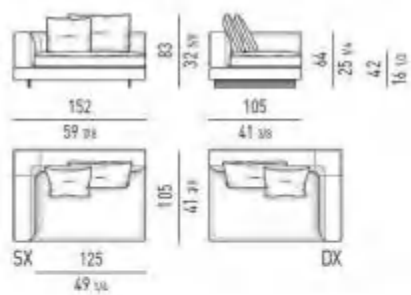

ELEMENTO TERMINALE **LOW CM 162**  
ELEMENT WITH ONE ARMREST **LOW CM 162**

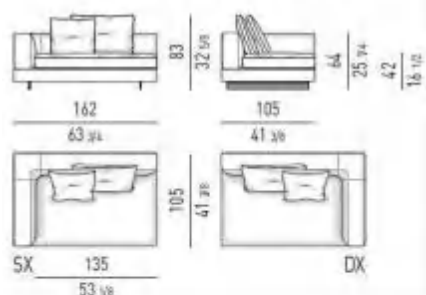

ELEMENTO TERMINALE **LOW CM 187**  
ELEMENT WITH ONE ARMREST **LOW CM 187**

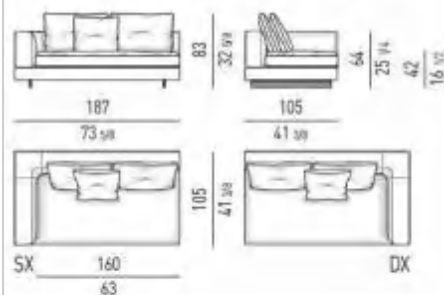

ELEMENTO TERMINALE **LOW CM 202**  
ELEMENT WITH ONE ARMREST **LOW CM 202**

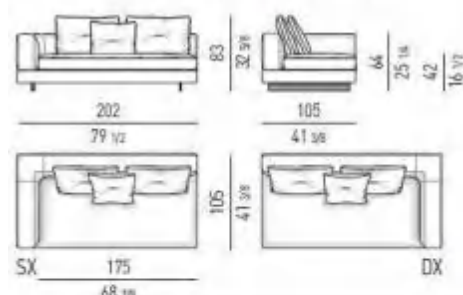

ELEMENTO TERMINALE **LOW CM 227**  
ELEMENT WITH ONE ARMREST **LOW CM 227**

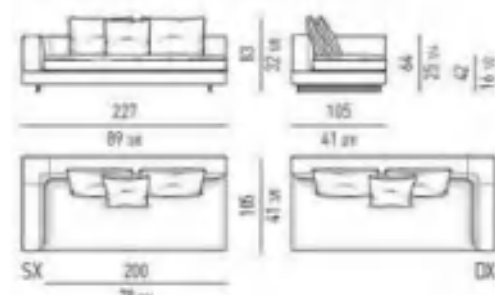

ELEMENTO TERMINALE **HIGH CM 152**  
ELEMENT WITH ONE ARMREST **HIGH CM 152**

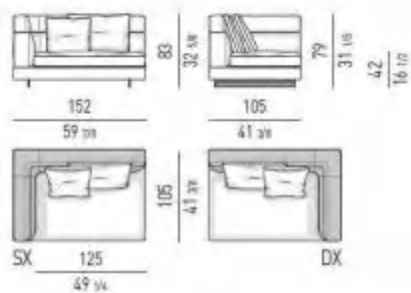

ELEMENTO TERMINALE **HIGH CM 162**  
ELEMENT WITH ONE ARMREST **HIGH CM 162**

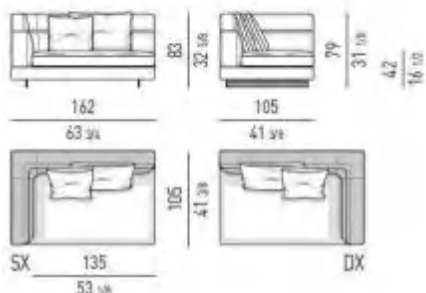

ELEMENTO TERMINALE **HIGH CM 187**  
ELEMENT WITH ONE ARMREST **HIGH CM 187**

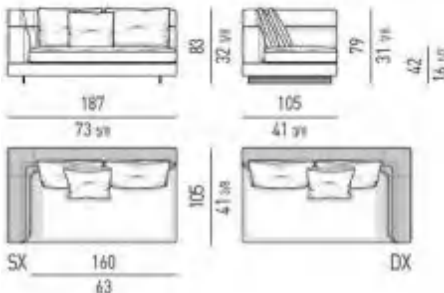

ELEMENTO TERMINALE **HIGH CM 202**  
ELEMENT WITH ONE ARMREST **HIGH CM 202**

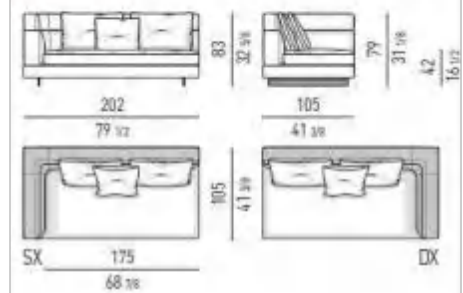

ELEMENTO TERMINALE **HIGH CM 227**  
ELEMENT WITH ONE ARMREST **HIGH CM 227**

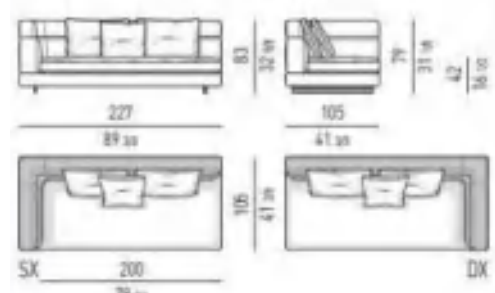

# 可选模块尺寸

## Technical Features

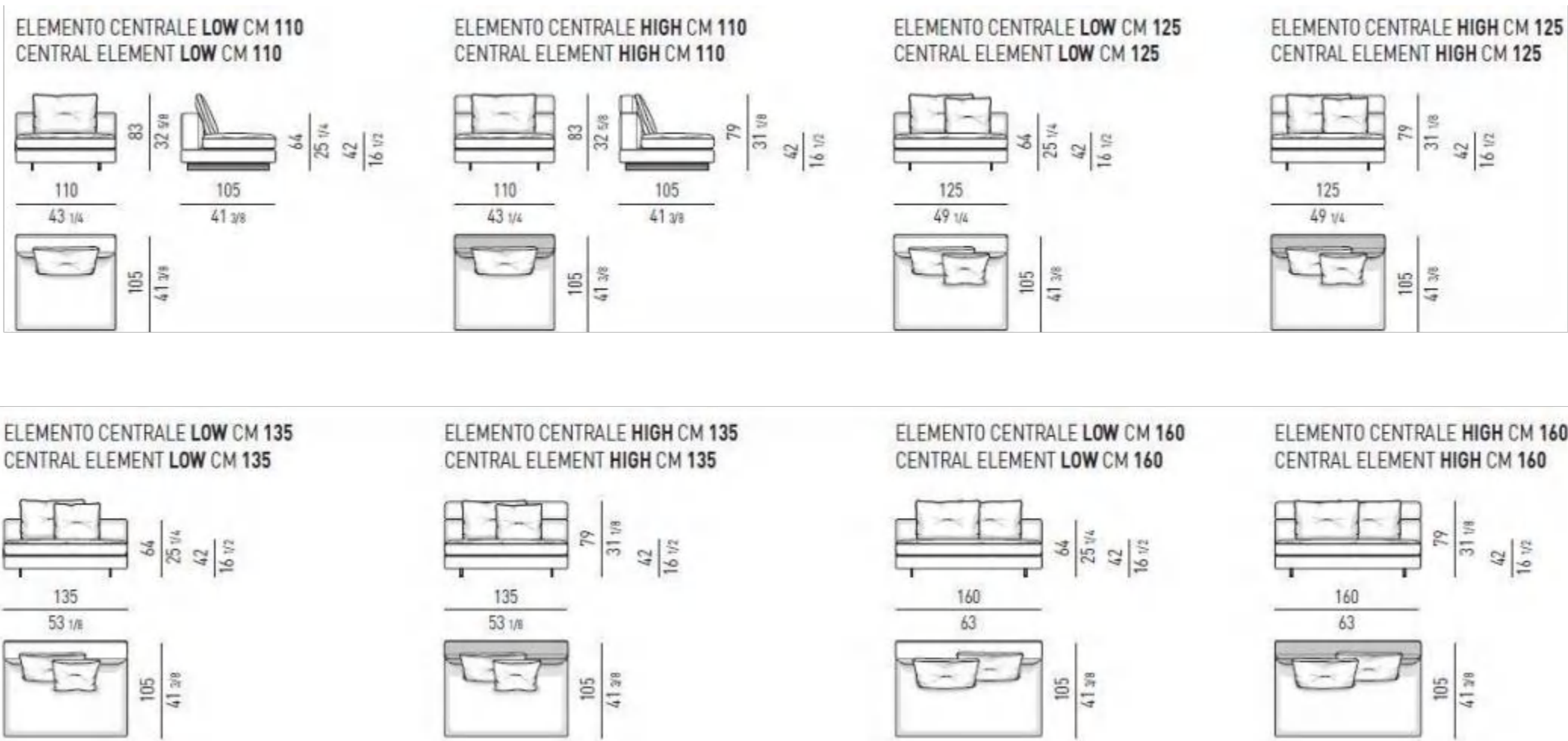

# 可选模块尺寸

## Technical Features

ELEMENTO TERMINALE PENISOLA **LOW** CM 202  
OPEN-END ELEMENT WITH ONE ARMREST **LOW** CM 202

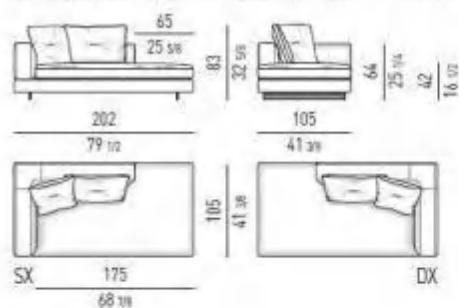

ELEMENTO TERMINALE PENISOLA **HIGH** CM 202  
OPEN-END ELEMENT WITH ONE ARMREST **HIGH** CM 202

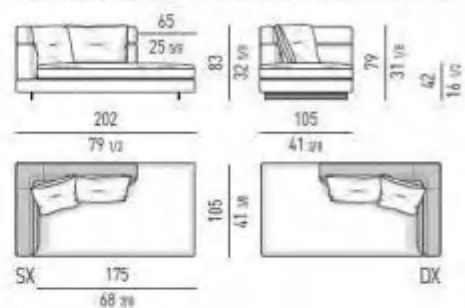

ELEMENTO TERMINALE PENISOLA **LOW** CM 227  
OPEN-END ELEMENT WITH ONE ARMREST **LOW** CM 227

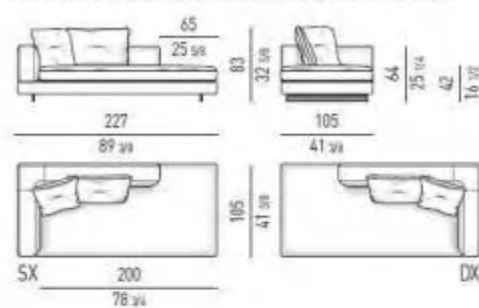

ELEMENTO TERMINALE PENISOLA **HIGH** CM 227  
OPEN-END ELEMENT WITH ONE ARMREST **HIGH** CM 227

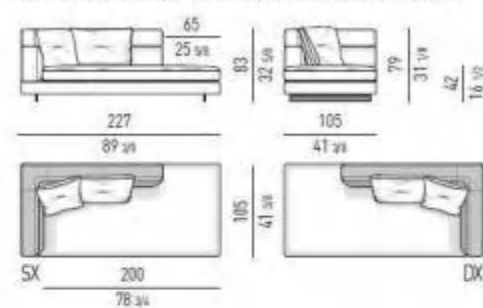

ELEMENTO TERMINALE PENISOLA **LOW** CM 217  
OPEN-END ELEMENT WITH ONE ARMREST **LOW** CM 217

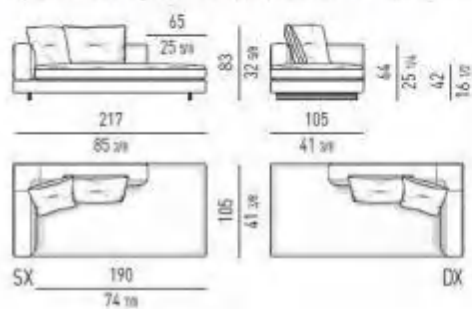

ELEMENTO TERMINALE PENISOLA **HIGH** CM 217  
OPEN-END ELEMENT WITH ONE ARMREST **HIGH** CM 217

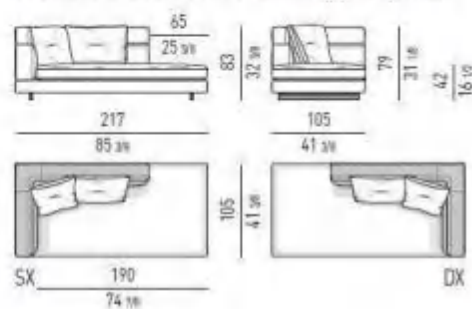

ELEMENTO TERMINALE PENISOLA **LOW** CM 252  
OPEN-END ELEMENT WITH ONE ARMREST **LOW** CM 252

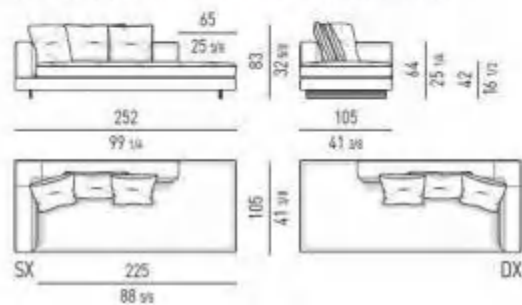

ELEMENTO TERMINALE PENISOLA **HIGH** CM 252  
OPEN-END ELEMENT WITH ONE ARMREST **HIGH** CM 252

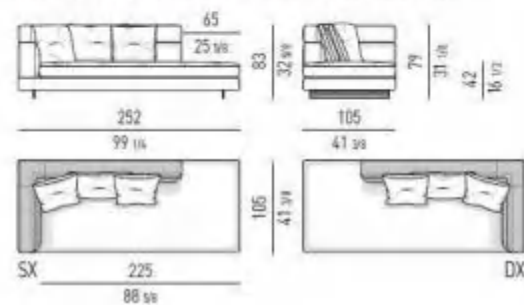

# 可选模块尺寸

## Technical Features

ELEMENTO PENISOLA **LOW** CM 175  
OPEN-END ELEMENT **LOW** CM 175

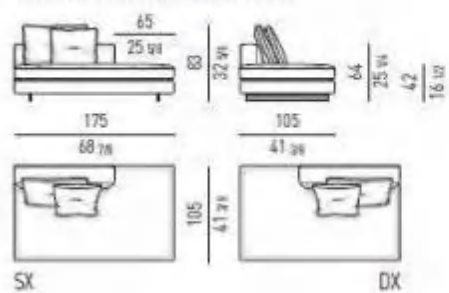

ELEMENTO PENISOLA **HIGH** CM 175  
OPEN-END ELEMENT **HIGH** CM 175

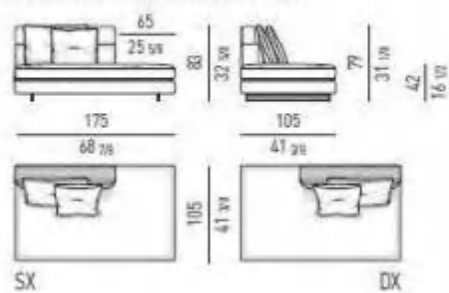

ELEMENTO PENISOLA **LOW** CM 190  
OPEN-END ELEMENT **LOW** CM 190

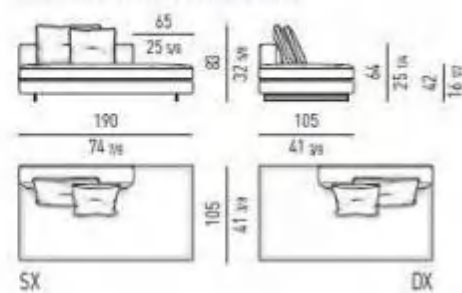

ELEMENTO PENISOLA **HIGH** CM 190  
OPEN-END ELEMENT **HIGH** CM 190

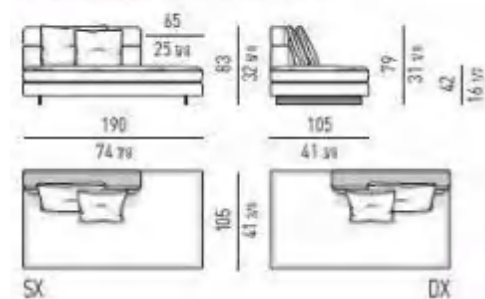

POUF CM 105x105  
OTTOMAN CM 105x105

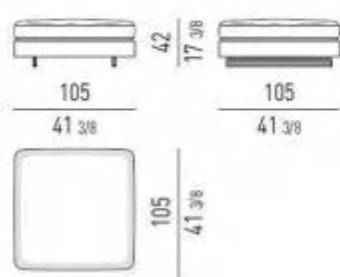

CUSCINI SCHIENALE OPTIONAL  
OPTIONAL BACKREST CUSHIONS



# 可选模块尺寸

## Technical Features

ELEMENTO TERMINALE **LOW** CM 162  
ELEMENT WITH ONE ARMREST **LOW** CM 162

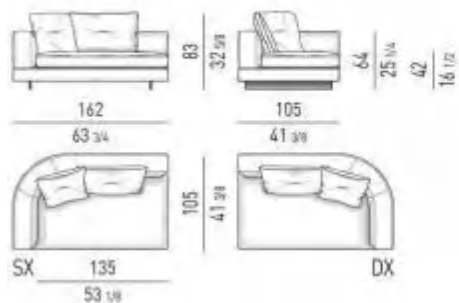

ELEMENTO TERMINALE **HIGH** CM 162  
ELEMENT WITH ONE ARMREST **HIGH** CM 162

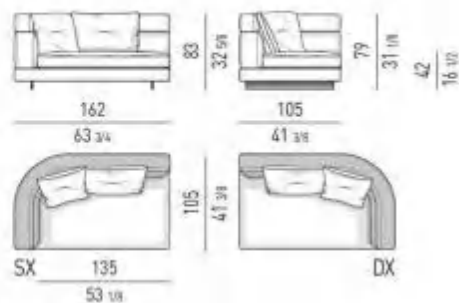

CHAISE-LONGUE **RAY** - **LOW** CM 187x167  
CHAISE-LONGUE **RAY** - **LOW** CM 187x167

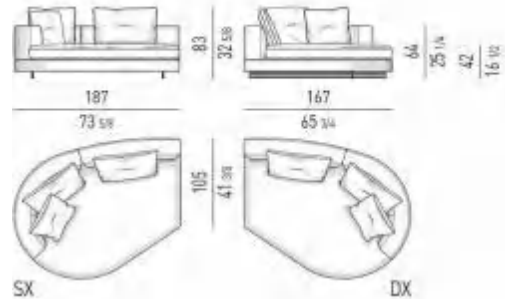

CHAISE-LONGUE **RAY** - **MIX** CM 187x167  
CHAISE-LONGUE **RAY** - **MIX** CM 187x167

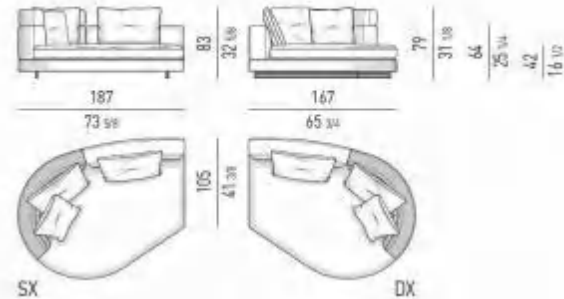

ELEMENTO TERMINALE **PENISOLA** **LOW** CM 227  
OPEN-END ELEMENT WITH ONE ARMREST **LOW** CM 227

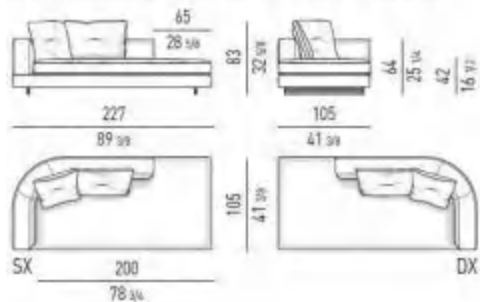

ELEMENTO TERMINALE **PENISOLA** **HIGH** CM 227  
OPEN-END ELEMENT WITH ONE ARMREST **HIGH** CM 227

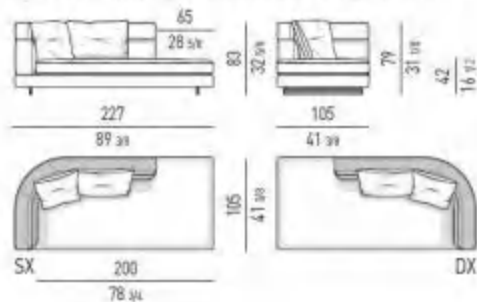

ELEMENTO TERMINALE **PENISOLA** **LOW** CM 252  
OPEN-END ELEMENT WITH ONE ARMREST **LOW** CM 252

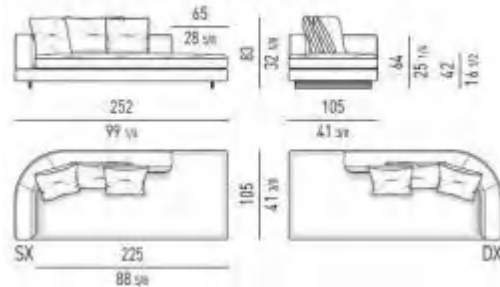

ELEMENTO TERMINALE **PENISOLA** **HIGH** CM 252  
OPEN-END ELEMENT WITH ONE ARMREST **HIGH** CM 252

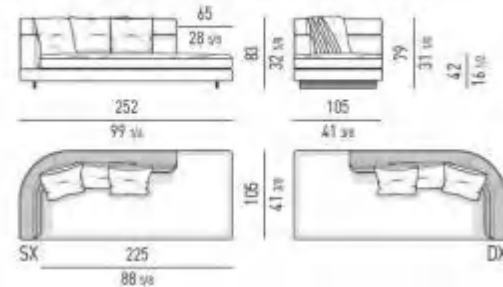



沙发组合系列类似于景观设计项目,各个元素的巧妙组合打造出让人耳目一新的室内住宅景观,起居区域采用别出心裁的组合形式,将规则的弧线和椭圆形融入线性设计,为其增添一份灵动感。



金属饰面  
MATERIAL

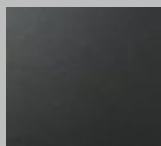

黑色哑光漆

模块沙发,可根据实际摆放面积,自由组合不同模块,腿部喷涂黑色哑光漆,面料可选皮或者布。

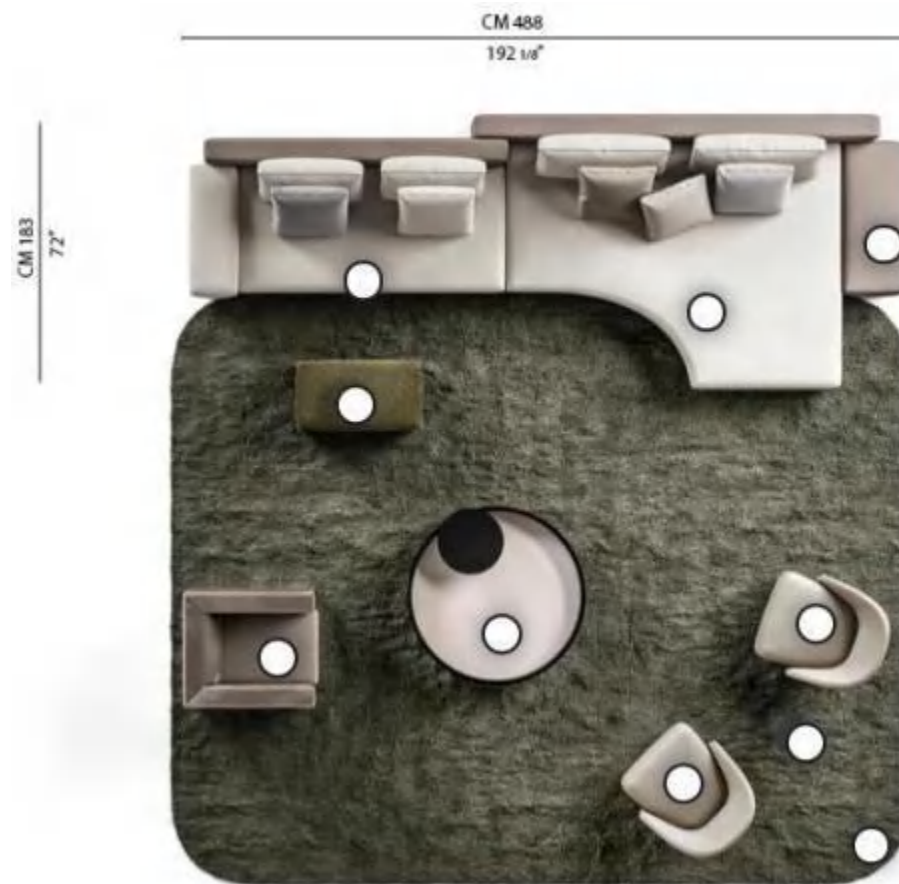

场景图片  
SPACEPICTURE



实物细节照片  
DETAIL PICTURE

ELEMENT WITH ONE ARMREST CM 195

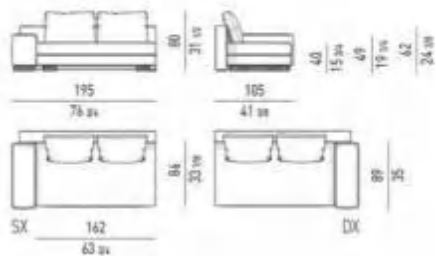

OFFSET SOFA CHAISE-LONGUE CM 205X169 - SEAT DEPTH CM 86

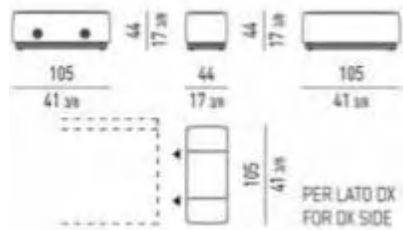
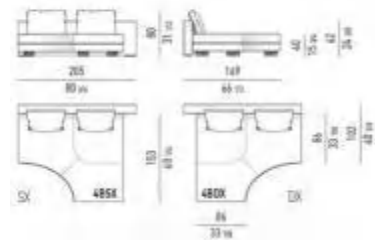

实物拍摄  
材质：MY-A2977  
- 1A 黑色哑光漆  
金属脚 尺寸见下图

可以用可移除的休闲凳来替代固定扶手,休闲

凳采用皮革或织物覆面,配备滚轮。

它不仅可以通过磁铁与沙发贴在一起,也可以将其移动,作

为额外的座椅或支撑表面来使用,还可以置于坐垫前方,构成自然的加长部件。休闲凳可以与 Amber 低矮家具的末端固定在一起。

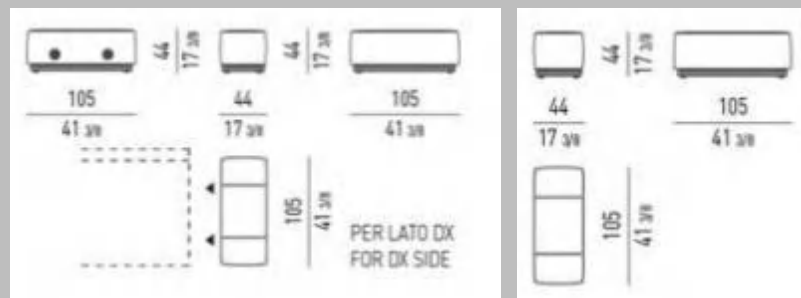
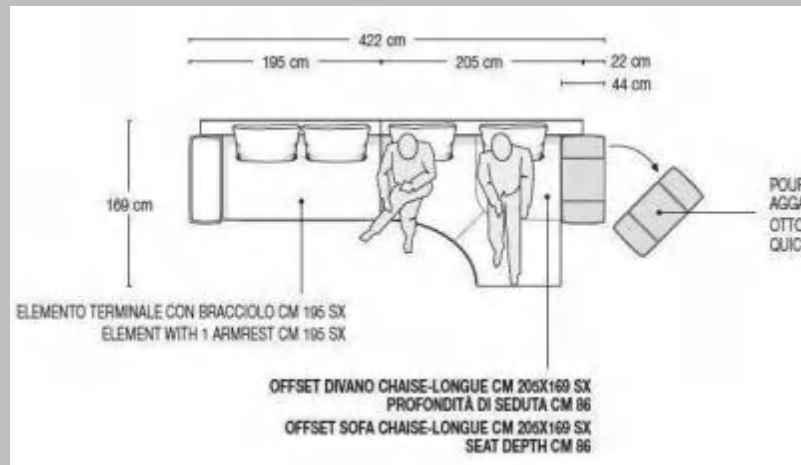

ELEMENT WITH ONE ARMREST CM 155

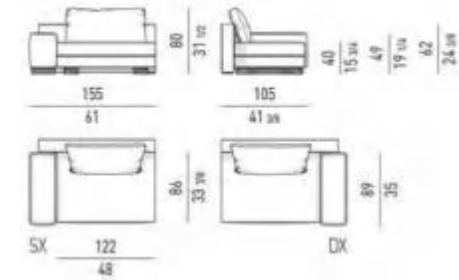

ELEMENT WITH ONE ARMREST CM 170

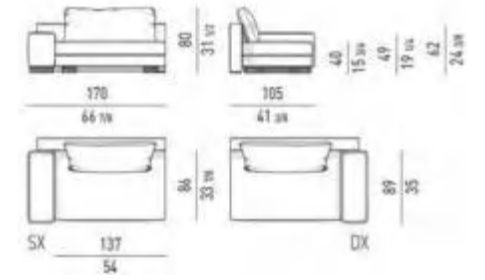

ELEMENT WITH ONE ARMREST CM 195

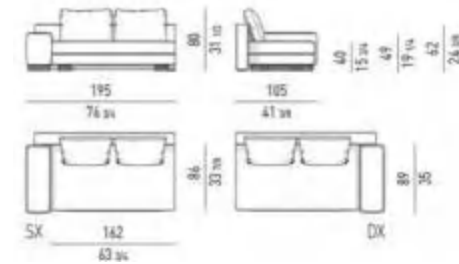

ELEMENT WITH ONE ARMREST CM 215

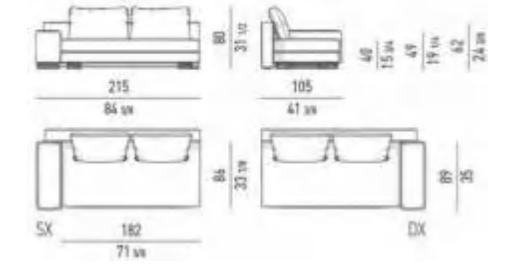

OFFSET SOFA CHAISE-LONGUE CM 205X169 - SEAT CM 86

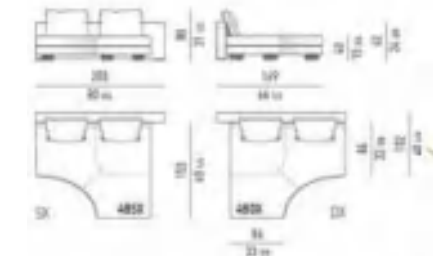

F通过沙发系列来对居住空间的设计加以创新,运用独具特

色的多种元素, 搭配别具一格的审美情趣, 融入优雅的比例设计和

无与伦比的舒适感。M系列集双重特质于一身: “D u v e t”组合

拥有柔软而包容的线条和超软靠垫,打造温暖舒适的非凡体验。

“D u v e t”的设计抚慰人心, 精致的细节做工重新对传统加以诠释, 平添一份具有现代感的古典风情。

“T a i l o r”组合拥有与众不同的个性,造型更加洗练,单组沙发的缝制设计别具一格,展现出图形魅力与现代意味。两种特质融合在一起, 打造出“多面玲珑”的组合形式, 在一天中的不同时刻, 用不同方式来享受沙发上的体验。

F系列沙发系列无疑是居住空间的主角,既可以在这里独享私密空间,也可以在这一闲适的环境中与朋友共度美好时光。沙发的支

金属饰面  
M A T E R I A L



金棕色艺术漆

## “Duvet”



## “Tailor”



组合方式  
HOW TO USE THEM

“Tailor”Wing



“Tailor”Mix



“Duvet”+ “Tailor”Wing



“Duvet”+ “Tailor” Mix



# 组合方式

HOW TO USE THEM

EXAMPLE 01  
Freeman "Duvet" + Freeman "Tailor"



EXAMPLE 02  
Freeman "Tailor"



EXAMPLE 04  
Freeman "Duvet" + Freeman "Tailor"



**Gray边几** 特别为搭配沙发系列而设计。外侧两边开放式的结构为金属板材质搭配金棕色金属漆表面,内侧部分则使用米灰色鲍迪豆木饰贴面,打造出极为优雅的美学效果。内部空间的尺寸经过特别设计,选配Gray托盘,这两个部件也采用米灰色的鲍迪豆木饰贴面。得益于Gray边几的独特造型,它既可以放置于两张座椅之间,也可以摆放在沙发的侧边。

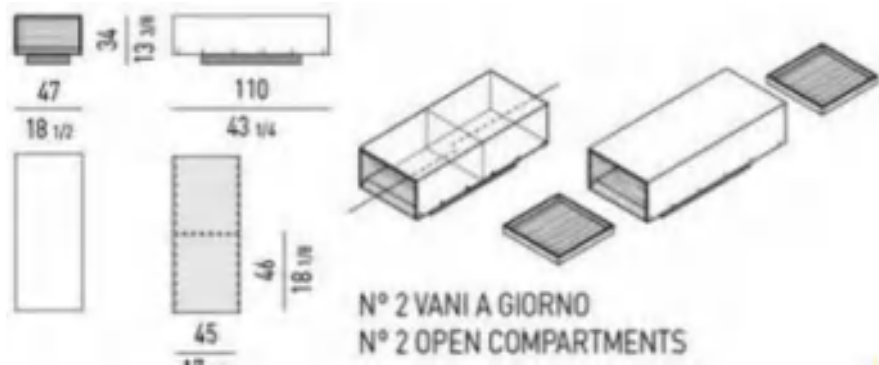
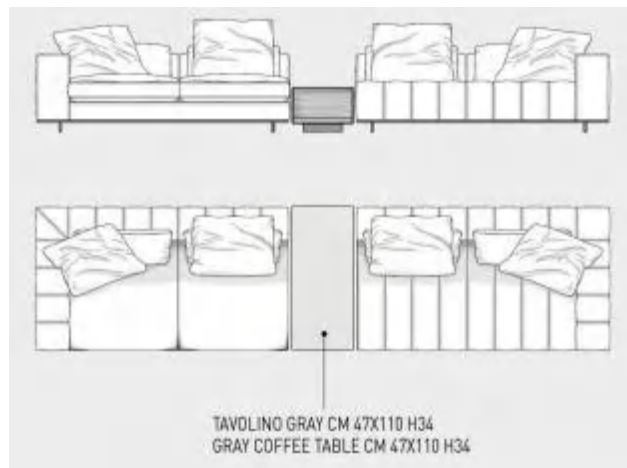

### 产品信息

尺寸: 47\*110\*34

材质: 金棕色艺术漆+ 鲍迪豆木皮

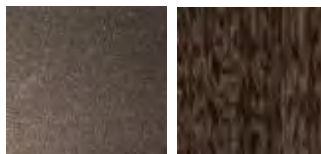





## 细节照片

DETAILPICTURE



这一组沙发座椅系列拥有双重个性：一是让人尽享放松的柔软温馨，二是颇具动感和当代精神的风范



# 可选模块尺寸 - “Duvet”

Technical Features

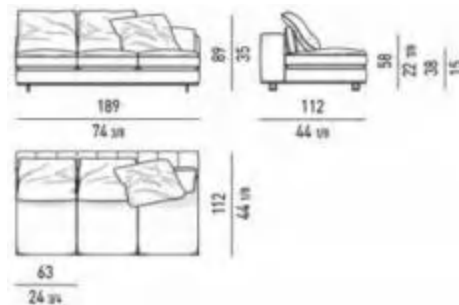
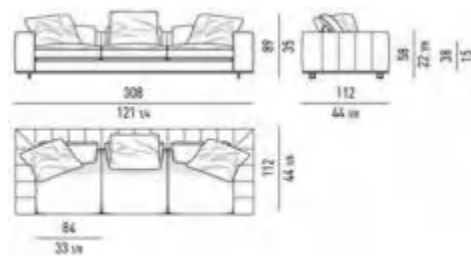
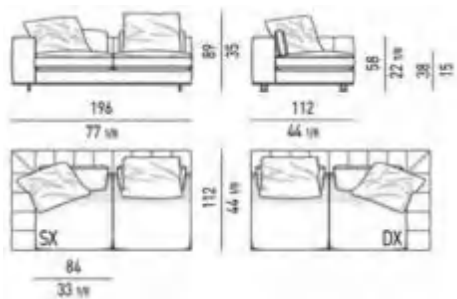
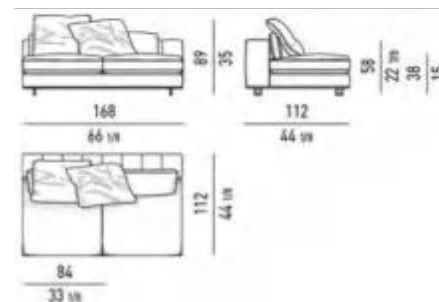
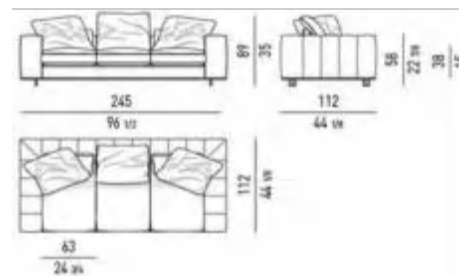
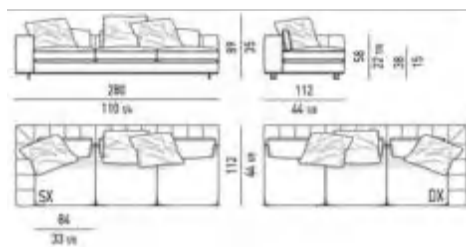
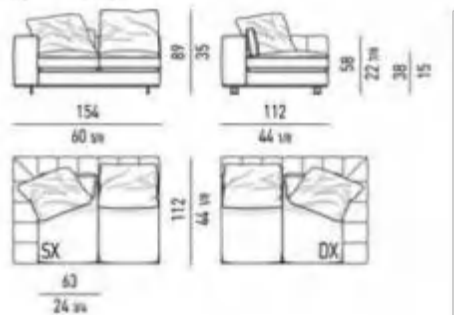
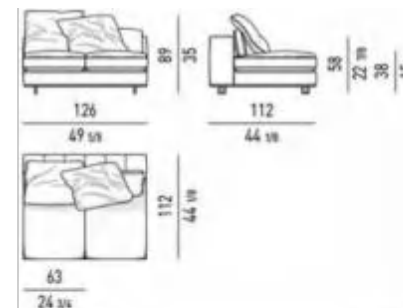
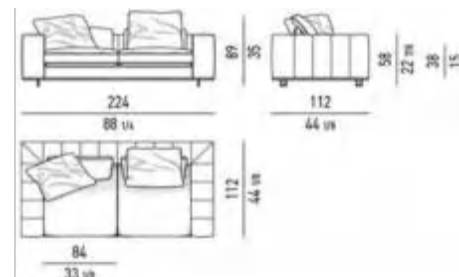
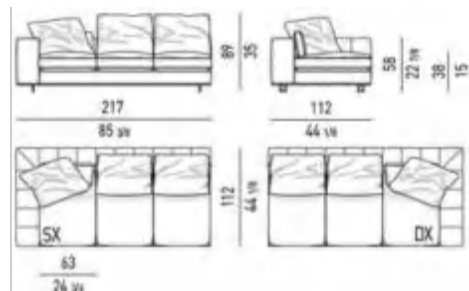
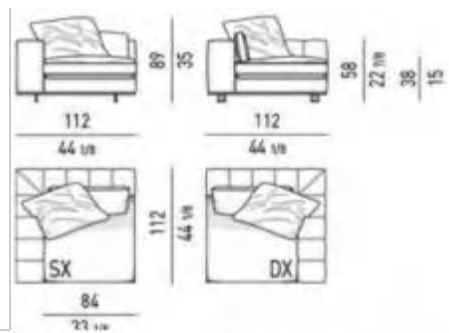

# 可选模块尺寸 - “Duvet”

Technical Features

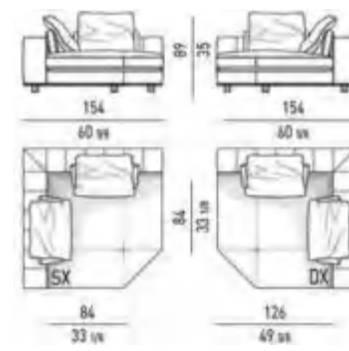
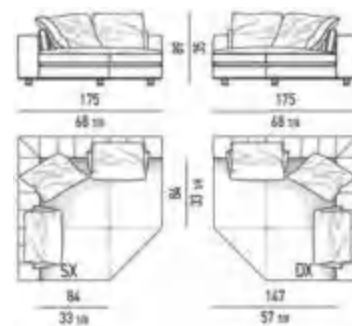
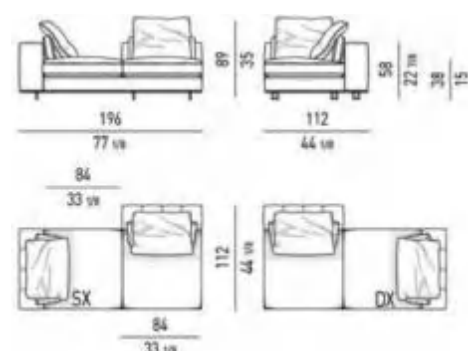
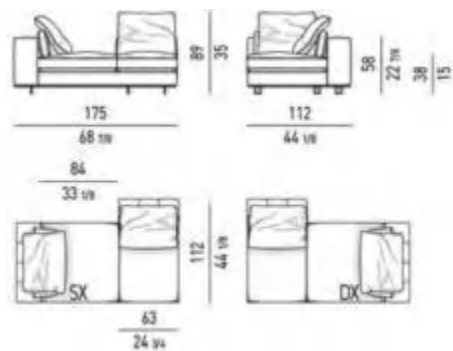
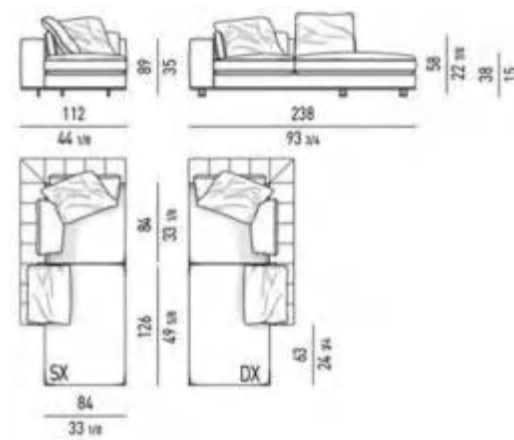
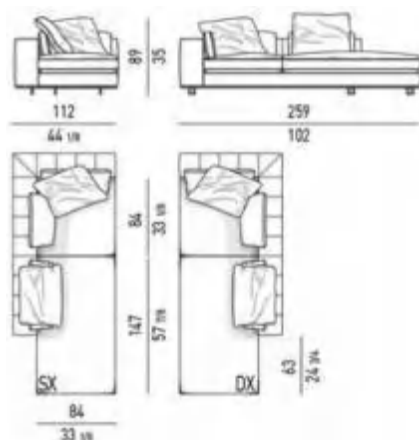
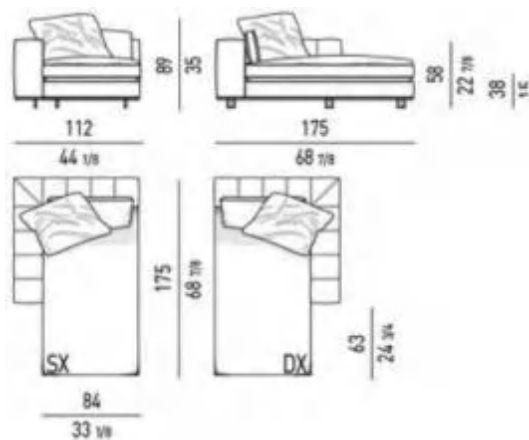



# 可选模块尺寸 - “Tailor”

Technical Features

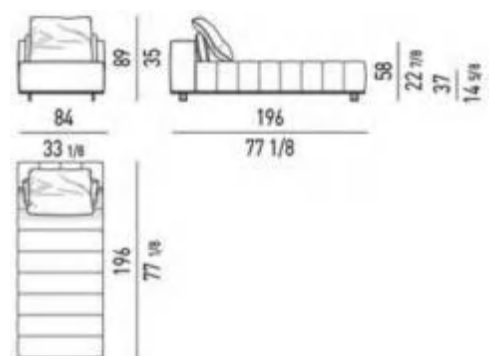
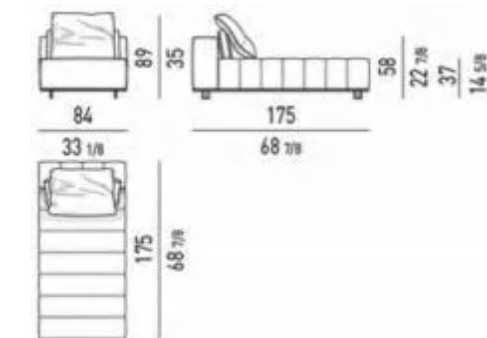
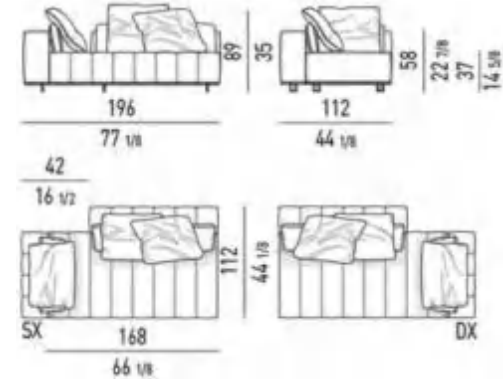
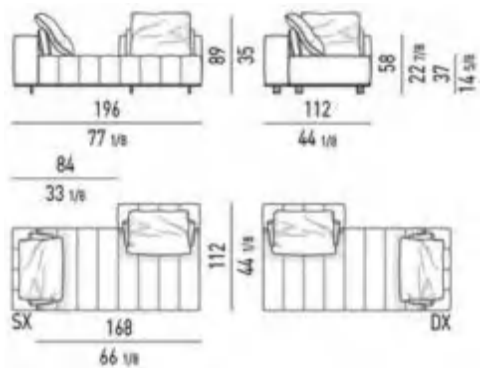
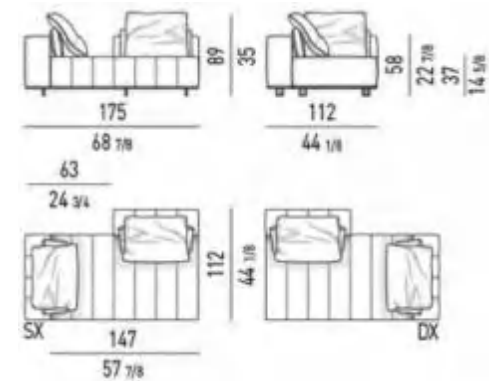
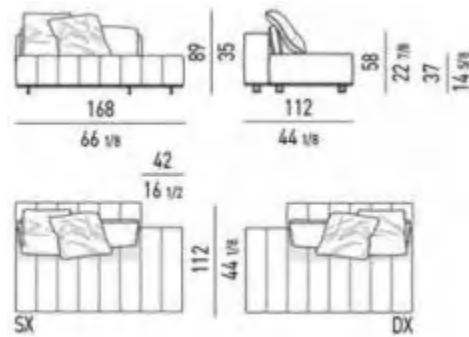
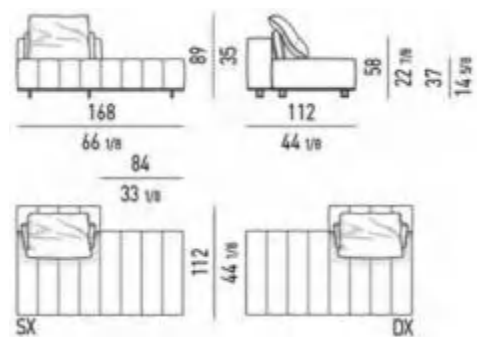
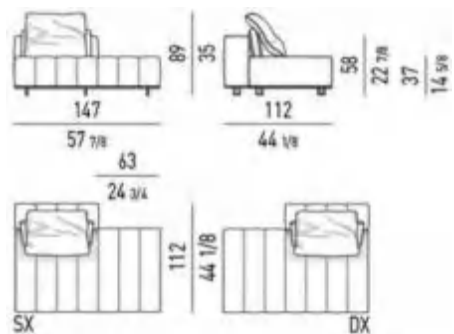

# 可选模块尺寸 - “Tailor”wing

Technical Features

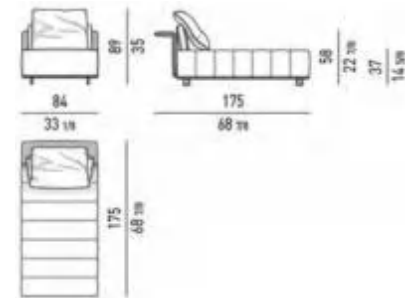
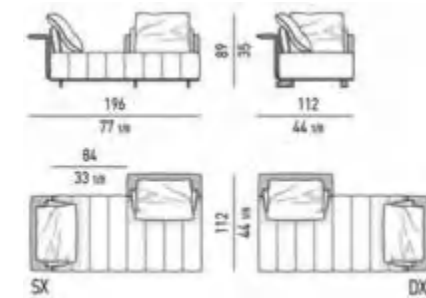
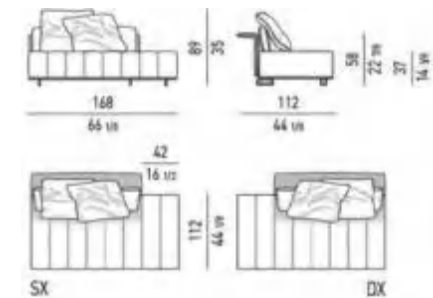
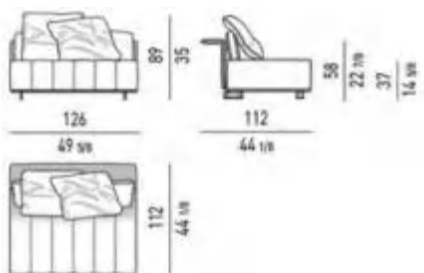
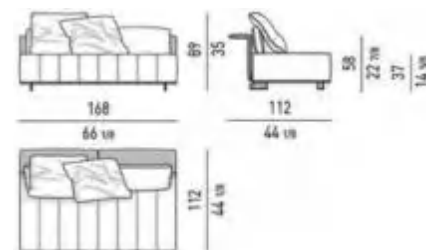
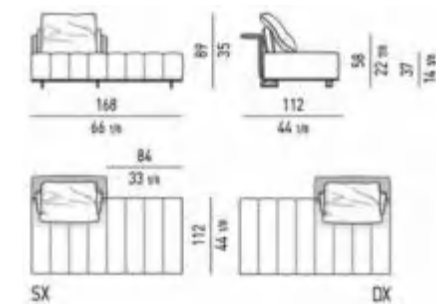
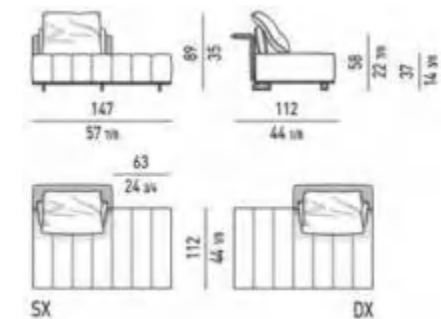
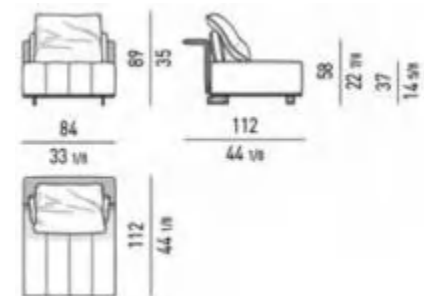
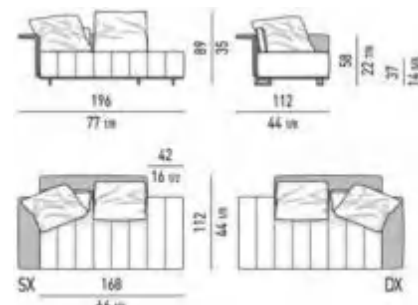
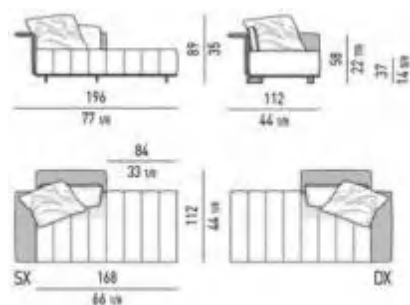
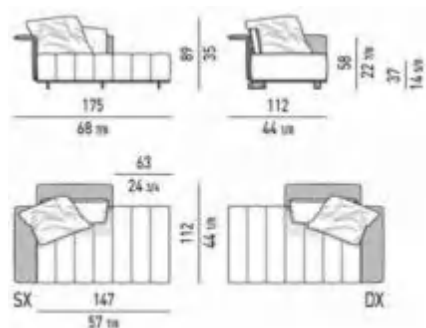
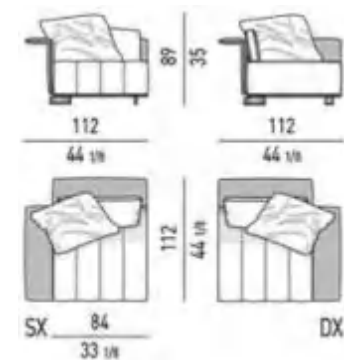

# 可选模块尺寸 - “Tailor”wing

Technical Features

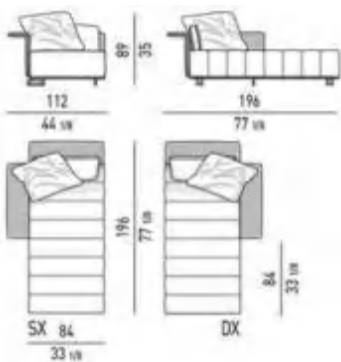
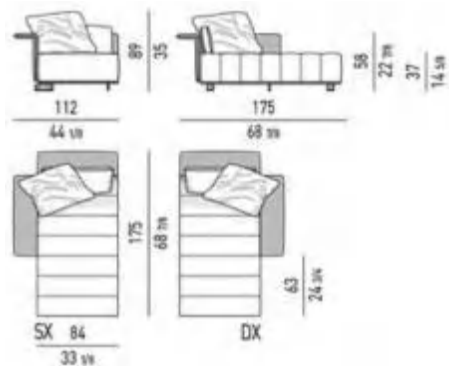
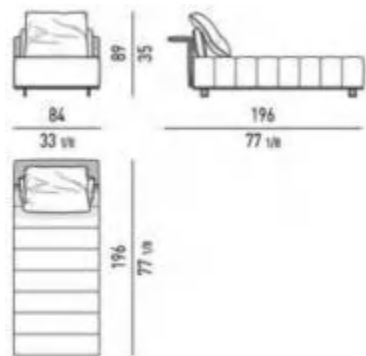



# 可选模块尺寸 - “Tailor”Mix

Technical Features

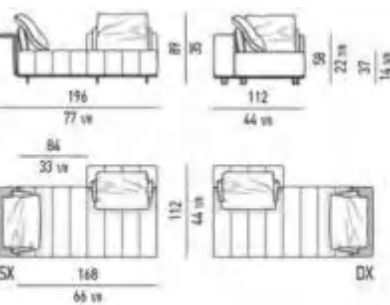
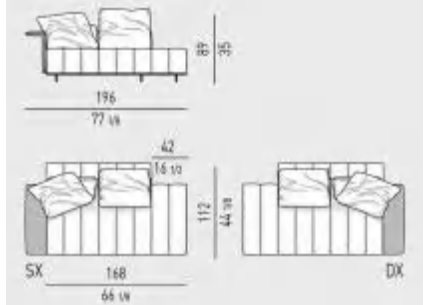
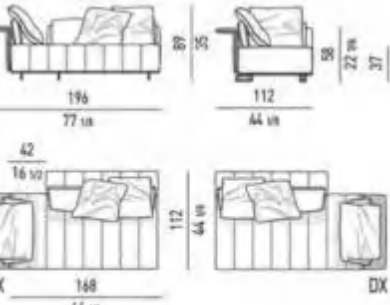
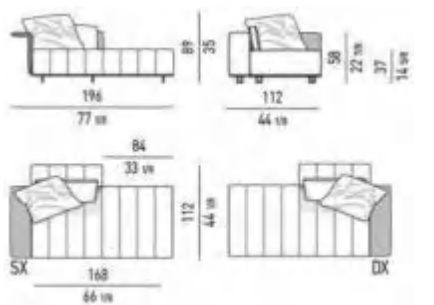
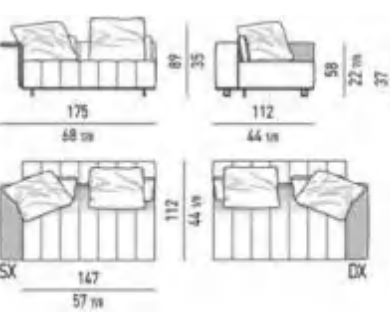
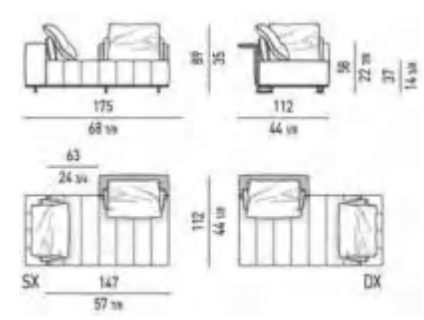
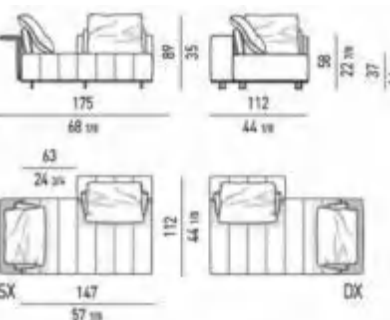
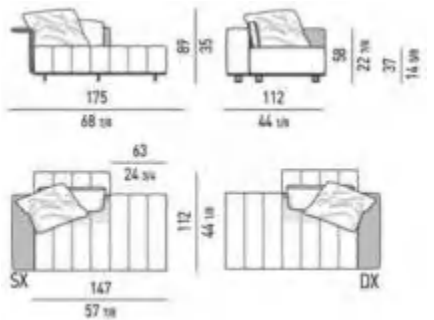
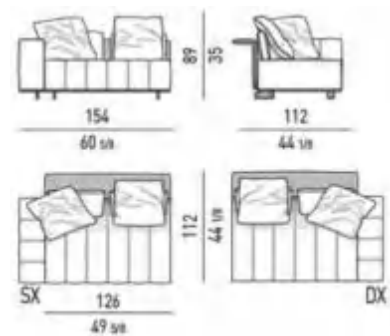
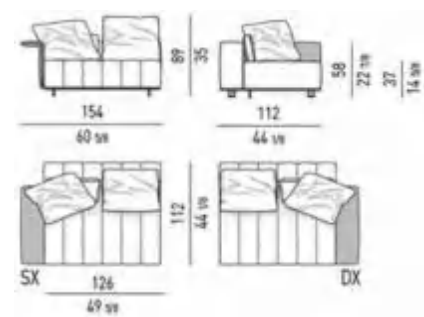
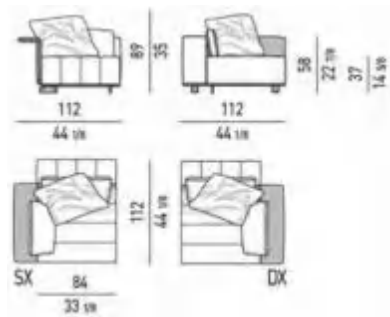
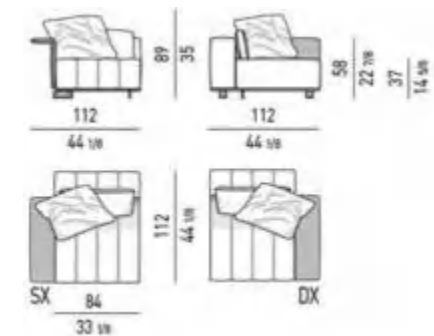

# 可选模块尺寸 - “Tailor”Mix

Technical Features

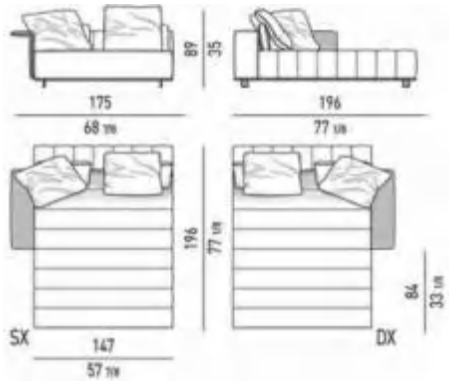
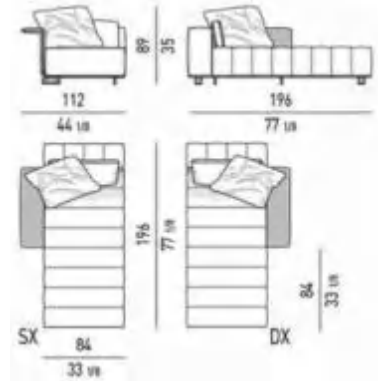
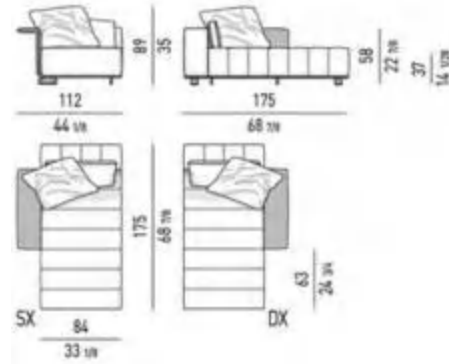
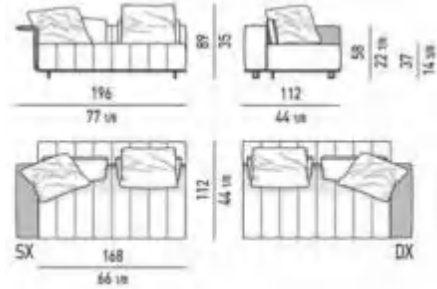
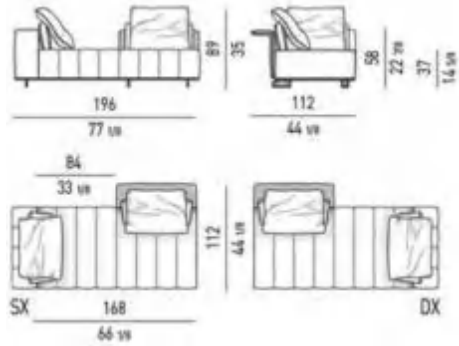

# 可选模块尺寸 - Bench

Technical Features

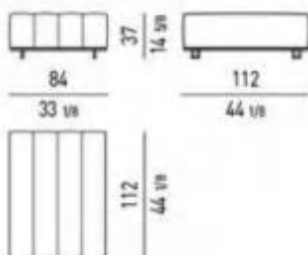
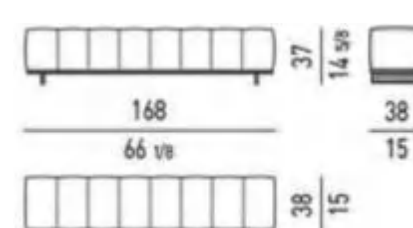
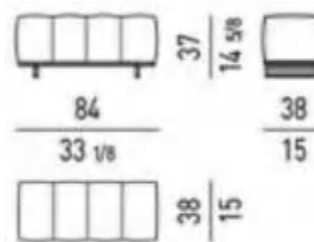
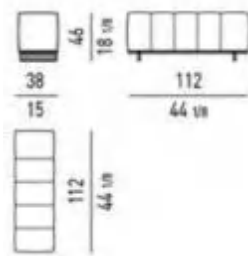
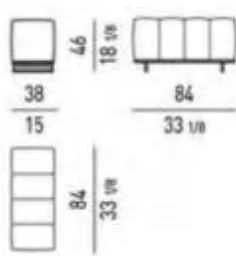
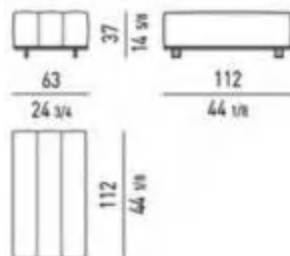
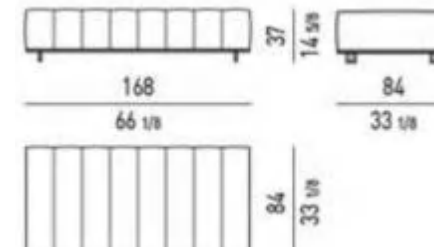
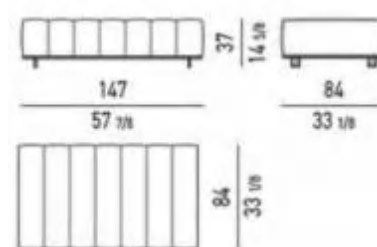
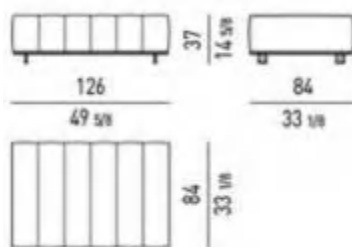
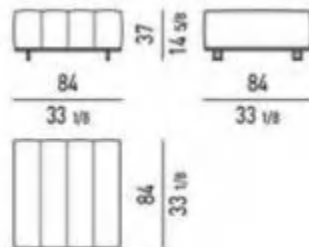
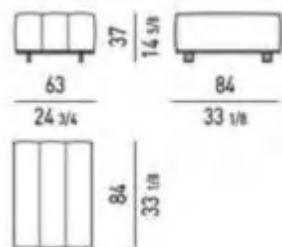



底框超纤皮硬包+坐垫及靠背软包

底框超纤皮硬包可选型号：

超纤硬皮/ FAB.3 (按照三等模布设计)				
LZ-PAN-03 FAB.3	LZ-PAN-02 FAB.3	LZ-PAN-01 FAB.3	LZ-PAN-21 FAB.3	LZ-PAN-20 FAB.3
LZ-PAN-6 FAB.3	LZ-PAN-10 FAB.3	LZ-PAN-15 FAB.3		

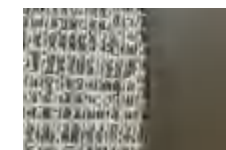
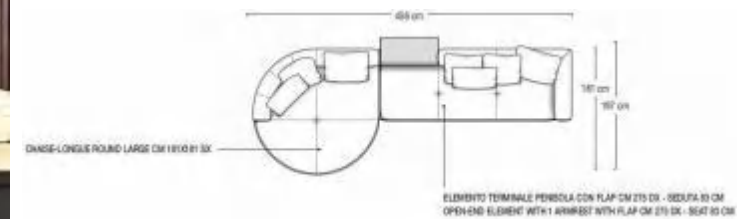

超纤硬皮：LZ-PAN-6/面料：MY-A2976-2A

# 可选模块尺寸 - module 83CM

Technical Features

**DIVANO CM 214**  
SOFA CM 214

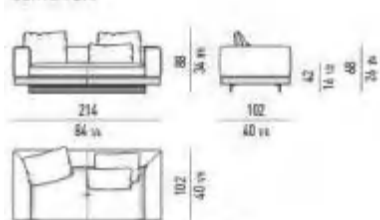

**DIVANO CON FLAP CM 230**  
SOFA WITH FLAP CM 230

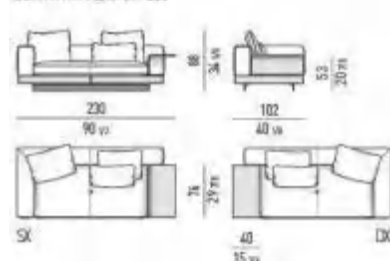

**DIVANO CM 297**  
SOFA CM 297

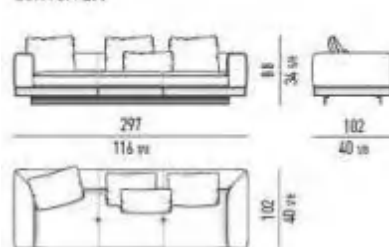

**DIVANI-DAYBED | DAYBED-SOFAS**

**DIVANO-DAYBED CON FLAP CM 297**  
DAYBED-SOFA WITH FLAP CM 297

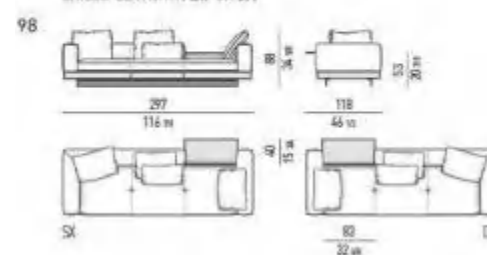

**DIVANO CON FLAP CM 313**  
SOFA WITH FLAP CM 313

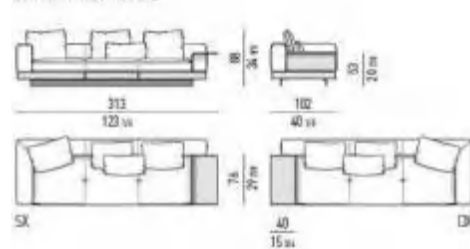

**ELEMENTI TERMINALI | ELEMENTS WITH 1 ARMREST**

**ELEMENTO TERMINALE CM 192**  
ELEMENT WITH 1 ARMREST CM 192

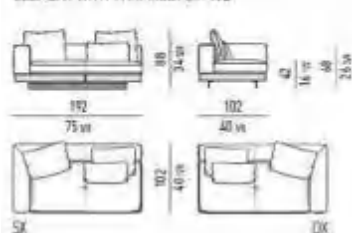

**ELEMENTO TERMINALE PENISOLA CON FLAP CM 192**  
OPEN-END ELEMENT WITH 1 ARMREST AND FLAP CM 192

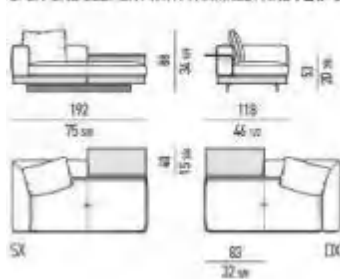

**ELEMENTO TERMINALE CON FLAP CM 208**  
ELEMENT WITH 1 ARMREST AND FLAP CM 208

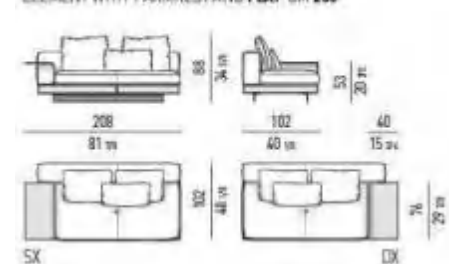

**ELEMENTO TERMINALE CM 275**  
ELEMENT WITH 1 ARMREST CM 275

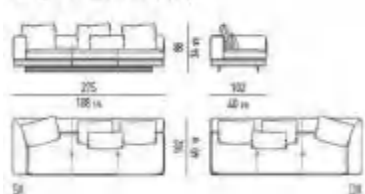

**ELEMENTO TERMINALE OPEN CON FLAP CM 275**  
OPEN ELEMENT WITH 1 ARMREST AND FLAP CM 275

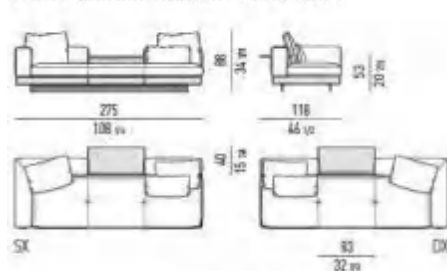

**ELEMENTO DAYBED CON FLAP CM 275**  
DAYBED ELEMENT WITH FLAP CM 275

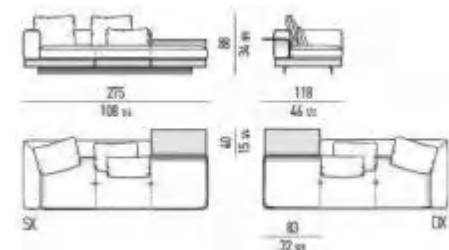
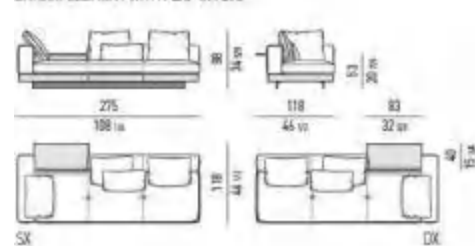

# 可选模块尺寸 - module 83CM

Technical Features

ELEMENTO TERMINALE CON FLAP CM 291  
ELEMENT WITH 1 ARMREST AND FLAP CM 291

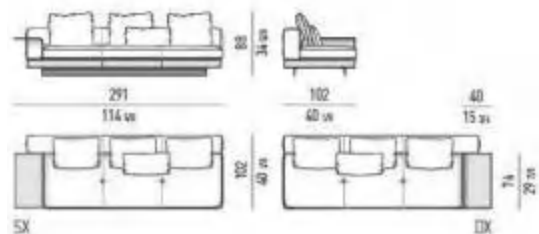

ELEMENTI PENISOLA | OPEN-END ELEMENTS

ELEMENTO PENISOLA CM 170  
OPEN-END ELEMENT CM 170

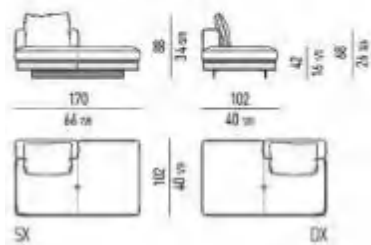

ELEMENTO CENTRALE CM 170  
CENTRAL ELEMENT CM 170

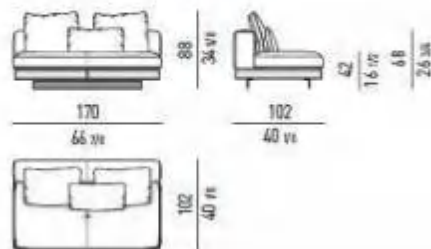

ELEMENTO PENISOLA CON FLAP CM 170  
OPEN-END ELEMENT WITH FLAP CM 170

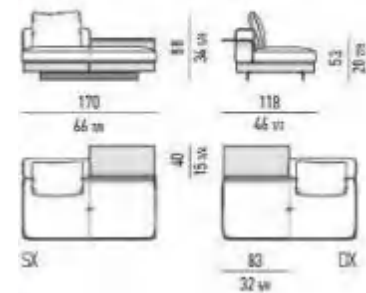

# 可选模块尺寸 - module 63CM

## Technical Features

DIVANO CM 252  
SOFA CM 252

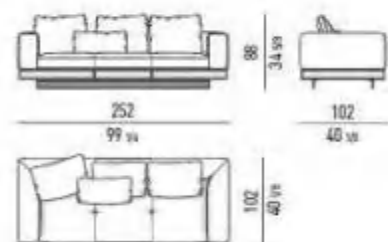

DIVANI-DAYBED | DAYBED-SOFAS

DIVANO-DAYBED CON FLAP CM 252  
DAYBED-SOFA WITH FLAP CM 252

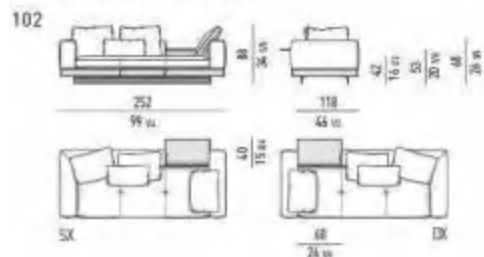

DIVANO CON FLAP CM 268  
SOFA WITH FLAP CM 268

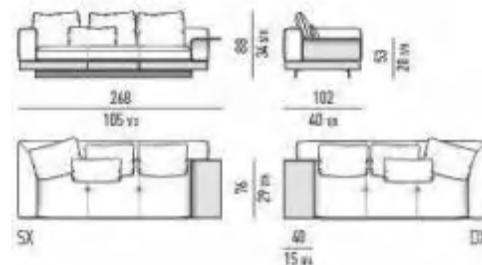

ELEMENTI TERMINALI | ELEMENTS WITH 1 ARMREST

ELEMENTO TERMINALE CM 162  
ELEMENT WITH 1 ARMREST CM 162

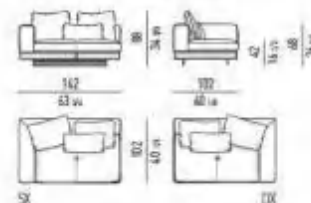

ELEMENTO TERMINALE PENISOLA CON FLAP CM 162  
OPEN-END ELEMENT WITH 1 ARMREST AND FLAP CM 162

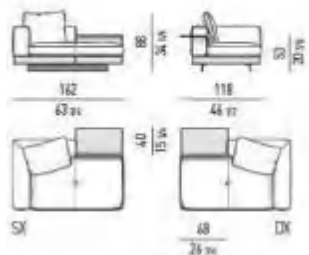

ELEMENTO TERMINALE CON FLAP CM 178  
ELEMENT WITH 1 ARMREST AND FLAP CM 178

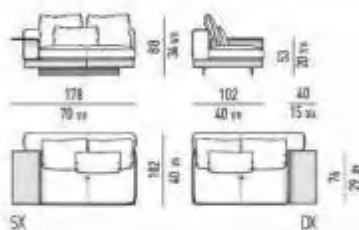

ELEMENTO TERMINALE CM 230  
ELEMENT WITH 1 ARMREST CM 230

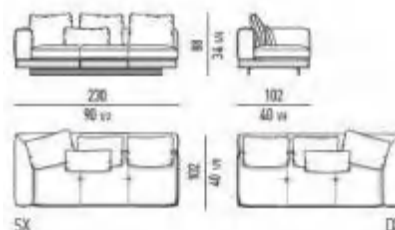

ELEMENTO DAYBED CON FLAP CM 230  
DAYBED ELEMENT WITH FLAP CM 230

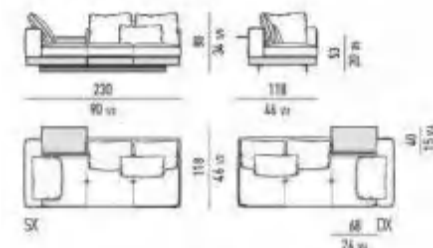

ELEMENTO TERMINALE OPEN CON FLAP CM 230  
OPEN ELEMENT WITH 1 ARMREST AND FLAP CM 230

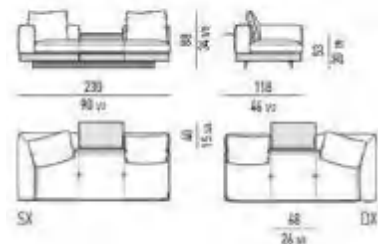

ELEMENTO TERMINALE PENISOLA CON FLAP CM 230  
OPEN-END ELEMENT WITH 1 ARMREST AND FLAP CM 230

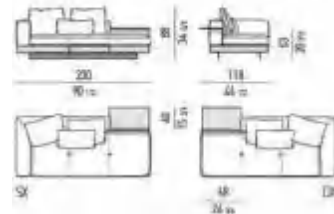

ELEMENTO TERMINALE CON FLAP CM 246  
ELEMENT WITH 1 ARMREST AND FLAP CM 246

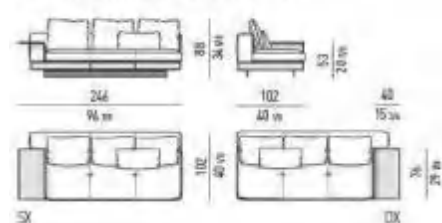

ELEMENTI CENTRALI | CENTRAL ELEMENTS

ELEMENTO CENTRALE CM 140  
CENTRAL ELEMENT CM 140

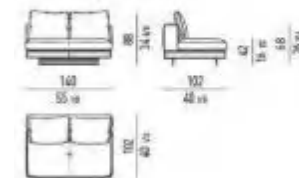

# 可选模块尺寸 - module 63CM

Technical Features

ELEMENTO PENISOLA CON FLAP CM 140  
OPEN-END ELEMENT WITH FLAP CM 140

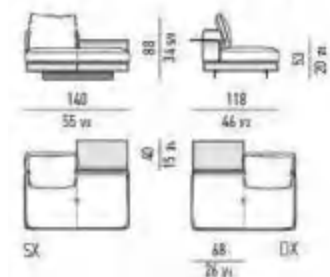

ELEMENTI PENISOLA | OPEN-END ELEMENTS

ELEMENTO PENISOLA CM 140  
OPEN-END ELEMENT CM 140

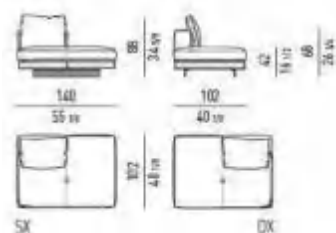

ELEMENTO CENTRALE CM 208  
CENTRAL ELEMENT CM 208

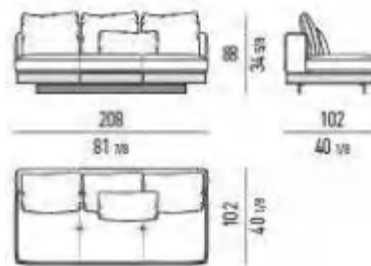

ELEMENTO PENISOLA CM 208  
OPEN-END ELEMENT CM 208

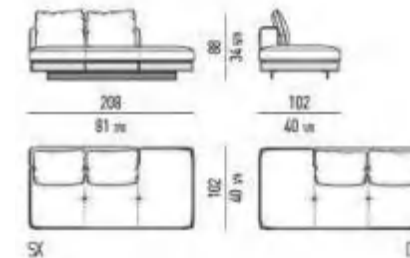

ELEMENTO PENISOLA CON FLAP CM 208  
OPEN-END ELEMENT WITH FLAP CM 208

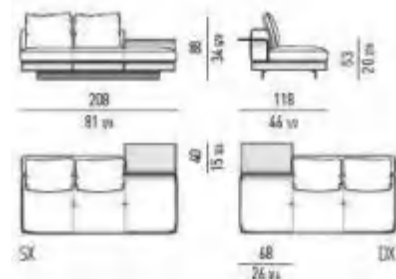

ELEMENTO CENTRALE OPEN CON FLAP CM 208  
OPEN CENTRAL ELEMENT WITH FLAP CM 208

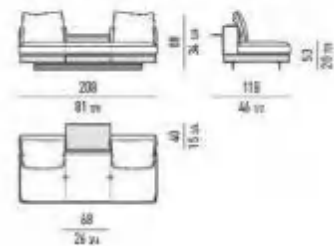



# 可选模块尺寸 - chaise longues

Technical Features

## CHAISE-LONGUES

### CHAISE-LONGUES SQUARE SMALL

CHAISE-LONGUE SQUARE SMALL CM 157X157  
CHAISE-LONGUE SQUARE SMALL CM 157X157

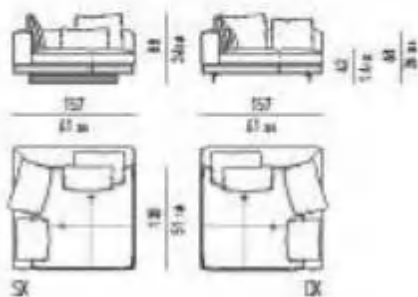

CHAISE-LONGUE SQUARE SMALL CON FLAP CM 173X157  
CHAISE-LONGUE SQUARE SMALL WITH FLAP CM 173X157

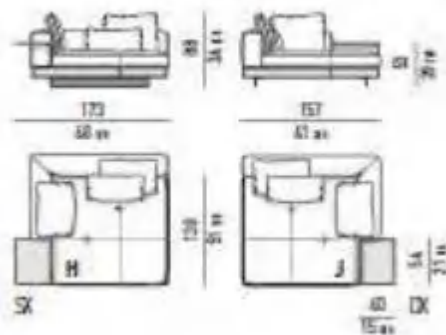

## CHAISE-LONGUES

### CHAISE-LONGUES SQUARE SMALL

CHAISE-LONGUE SQUARE SMALL CM 157X157  
CHAISE-LONGUE SQUARE SMALL CM 157X157

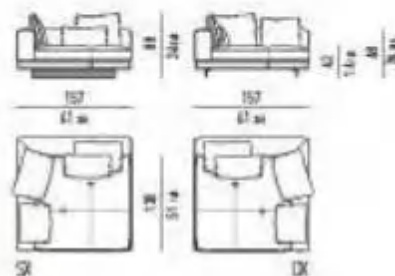

### CHAISE-LONGUES ROUND

CHAISE-LONGUE ROUND SMALL CM 165X165  
CHAISE-LONGUE ROUND SMALL CM 165X165

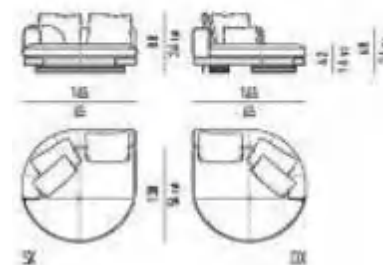



此系列通过其流畅的造型和平衡的圆润线条，探索不同类型的沙发座椅组合，从休闲的小扶手椅、更宽大舒适的扶手椅到沙发，突破经典造型风格，呈现创新解决方案。

Material.材质

Structure Legs :金属腿

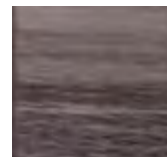

镜面镀铬

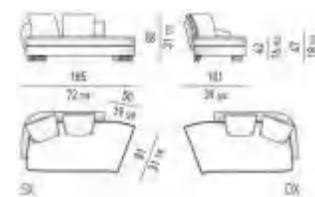
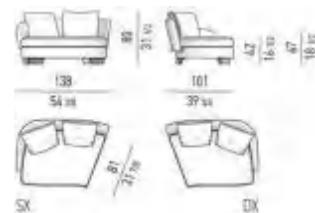





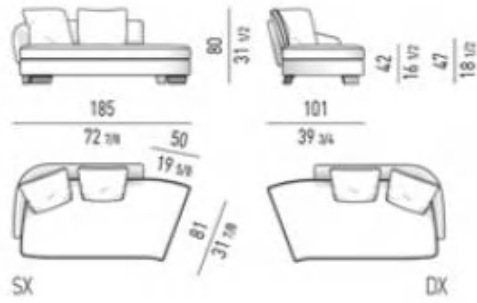
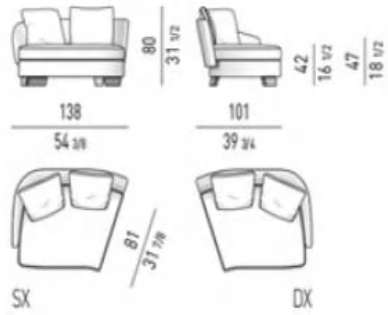

LARGE SEMI-ROUND ELEMENT CM 190

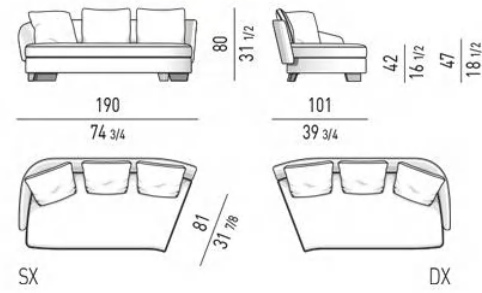

LARGE OPEN ROUND SOFA

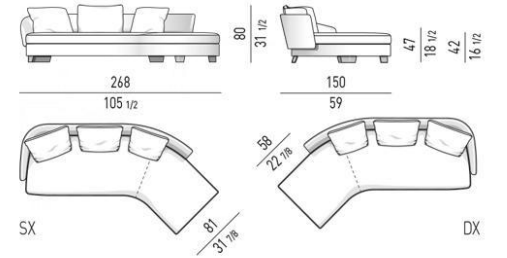

LARGE ROUND SOFA

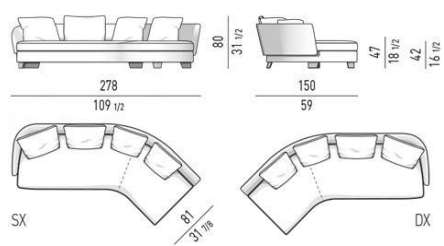

LARGE OPEN SOFA CHAISE-LONGUE

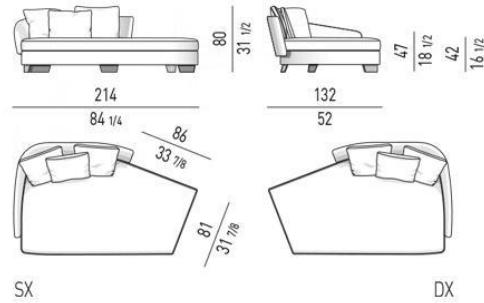

LARGE SOFA CHAISE-LONGUE

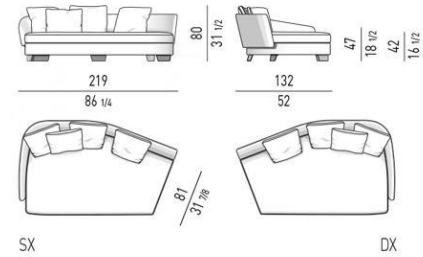

LARGE OPEN ELEMENT

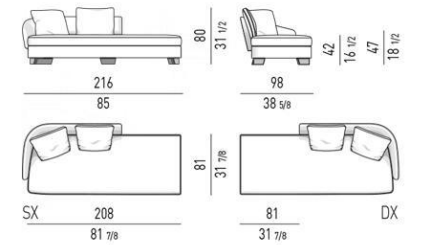

LARGE ELEMENT WITH 1 ARMREST CM 216

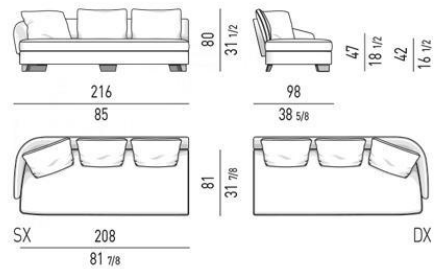



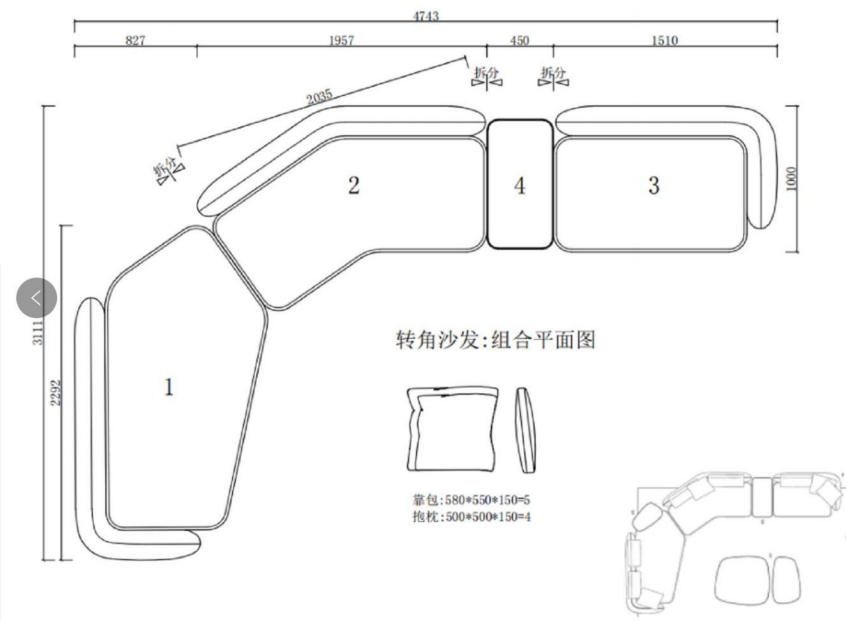

# 北极熊系列

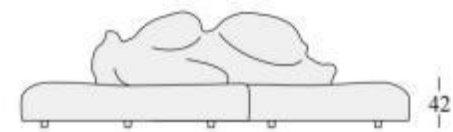
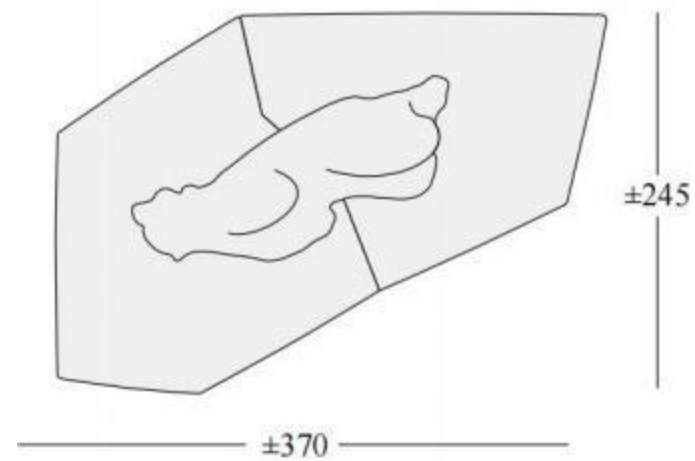





Connery 座椅系统具有现代感,具有强烈的建筑吸引力和让人联想到中世纪美国精神的纯线条,其精致的美学和设计立即吸引眼球。精美材料和精致细节的巧妙结合为其设计增添了一丝高级定制气息。

凭借其几何学的严谨性,底座与座椅的柔软性形成了原始的对比,它被设想为一个单一的靠垫,通过轻缝线定义座椅的宽度-83或68厘米-以及靠背和扶手的结构,覆盖在通道鹅绒填充。靠背和扶手形成一个整体,在角落处有45°分割。

除了织物覆盖物外,带衬垫的结构底座还可以采用皮革条覆盖物,采用与高级皮革箱包制作相同的技术制作而成。头枕和优雅的“C”形襟翼表面也参考了高端皮革制品的概念,它们与座椅元素无缝融合,以充满活力的节奏为构图注入活力。

结构底座在白兰地抛光漆面的挤压铝薄叶片上从地面升起,位于前面,使沙发具有吸引力和通风的外观,并让人想起行李箱和手提箱

的金属部件。



金棕色艺术漆





底框超纤皮硬包+坐垫及靠背软包

底框超纤皮硬包可选型号：

超纤硬皮 / FAB.3 (按照B等级布面校)				
LZ-PAN-31 FAB.3	LZ-PAN-32 FAB.3	LZ-PAN-31 FAB.3	LZ-PAN-31 FAB.3	LZ-PAN-31 FAB.3
LZ-PAN-31 FAB.3	LZ-PAN-31 FAB.3	LZ-PAN-31 FAB.3		

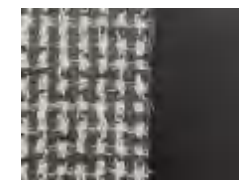

超纤硬皮：LZ-PAN-31/面料：MY-A2989-2A

底框超纤皮硬包+坐垫及靠背软包

底框超纤皮硬包可选型号:

超纤硬包/ FAB.3 (按照三等现有报价)				
LZ-PAN-18 FAB.1	LZ-PAN-32 FAB.2	LZ-PAN-20 FAB.3	LZ-PAN-24 FAB.4	LZ-PAN-25 FAB.5
LZ-PAN-6 FAB.1	LZ-PAN-10 FAB.4	LZ-PAN-10 FAB.5		

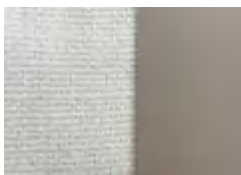

超纤硬皮: LZ-PAN-30/面料: MY-A2007-1A

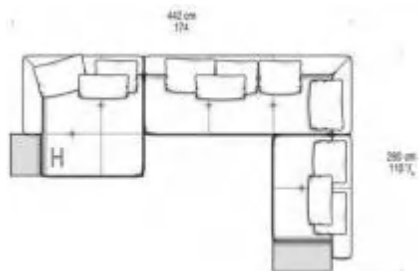

PZ-22系列



Il sostegno della seduta è ottenuto con doghe elastiche intrecciate. Cuscini sedili con inserti in piume ed inserti stabilizzanti in polietilene espanso. Cuscini schienali con imbottitura in piume a camera differenziabile. Piedi in finitura Alluminio a portali in nylon nero.

The seat spring system consists of interwoven elastic blades. Seat cushions with down padding and stabilizing insert in polyethylene foam. Backrest cushion with down padding in separate chambers. Cast aluminum feet with Nylon black feet and black nylon caps.

Le suspension de l'assise est obtenue avec des dogues élastiques tressées. Cuscins d'assise avec rembourrage en plumes et insert stabilisateur en mousse de polyéthylène. Cuscins de dossier avec rembourrage en plumes à zones différenciables. Pieds en finition d'aluminium avec Nylon Noir et embouts en nylon noir.

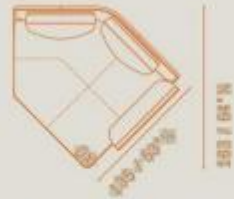

1425 x 600 mm

87 / 34" H

60 / 23" H

45 / 17" H



56 / 22" W / 39" W

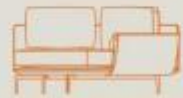

1427 x 65" W

93 x 35" W



87 / 34" H

60 / 23" H

45 / 17" H



56 x 22" W



1427 x 70" W

93 x 35" W

114 x 64" W

双人沙发,金属脚表面喷涂石墨色艺术漆,扶手可拆卸,当扶手与坐墩组合时,可放置在不同的位置,面料可选皮或者布。



金属饰面  
MATERIAL



石墨色艺术漆

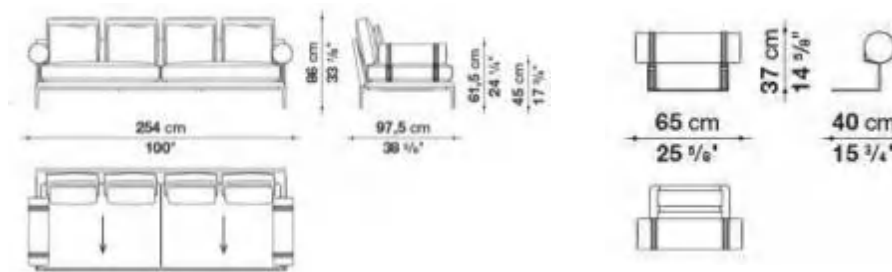

标配四个靠包





实物拍摄

尺寸：254\*975\*86H

材质：Boxer-774

石墨色艺术漆金属脚



柔和的造型、紧凑的比例和具有视觉冲击力的细节呈现出精致的美学语言,金属基座采用淡铜色的表面设计  
系列中的所有沙发座椅都拥有环抱式的线条,柔软的座椅和靠背带来温馨愉悦的感受。完美的造型和无可挑剔的覆面体现了生产工艺的高水平技艺,充分展现出坚实的工艺水准。

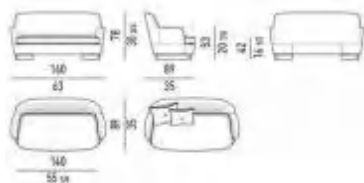

标配一个靠包

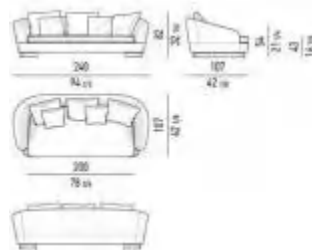

标配五个靠包 (三大+ 两小)



金棕色艺术漆



实物拍摄

尺寸：240\*107\*82H

材质：fab. 1MY-A842-10A

金棕色艺术漆金属脚





实物拍摄：

尺寸：160\*89\*78H

材质：cat.2 HS-Boxer-11

金棕色艺术漆金属脚





B006-M 沙发，脚为镜面枪黑色金属，面料可选皮或者布。

Material. 材质：

Structure Legs :金属腿：



镜面枪黑

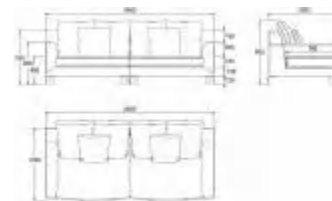
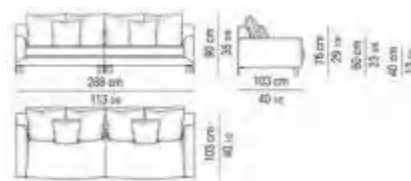

标配四个靠包

精心设计的外壳造型采用花冠式的展开方式,环抱着座垫,靠背的圆枕设计别具一格。造型方案呈现出雕塑感,在刚性结构与轻盈体量之间取得平衡,赋予座椅圆润温馨的美感。这一产品家族包括三座沙发、扶手休闲椅,外壳采用皮革材质,座椅和靠背则为织物面料,也可以选择覆面完全为织物面料或完全为皮革面料的配置方案。

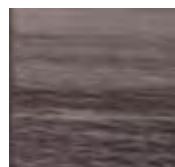

镜面枪黑

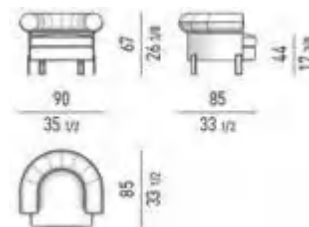
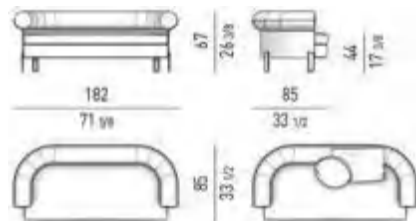



## 细节照片

DETAILPICTURE



引人注目的钢制支撑脚采用黑镍饰面,不仅是精致感的标志,也带来一份轻盈感。



此款不同寻常的风格,出自其之手的座椅系列充满特立独行的个性,运用轻盈的线条勾勒出扶手椅(提供带扶手和不带扶手的版本)、休闲小扶手椅、围手椅、两座沙发、三座沙发和休闲凳。  
 设计师采用讽刺意味颠覆了座椅支撑脚的传统概念,此番设计的支撑脚像是主体的延伸,被放置在结构之外。  
 基壳的柔软弧面突显线条的精致感和温馨感,搭配精心设计的扶手和造型圆润的靠垫。

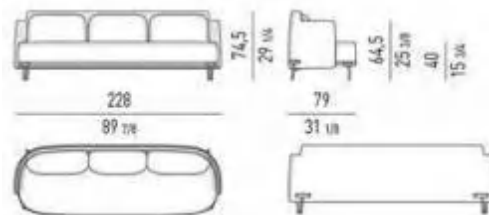
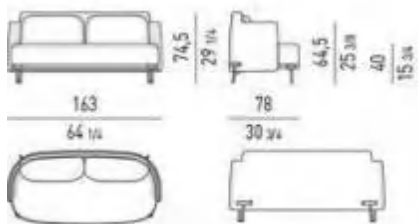

单人沙发,金属脚表面喷涂金棕色艺术漆,面料可选皮或者布。

Structure Legs :金属腿:



金棕色艺术漆





实物拍摄:

尺寸:163\*D 78\*H 74.5

材质: 后背cat. 2HS-BOXER-11

坐垫及靠包FAB. 1: MY-

A2267-

1A

金棕色艺术漆金属脚





B007-M 沙发，全软包面料可选皮或者布。

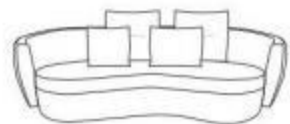

**DIMENSIONS**

H 33 -"  
W 91 -"  
D 41 -"  
SH 17 -"

实物拍摄

尺寸：2300\*103\*900H

材质：fab. 1MY-A2267-1A





L-03L系列

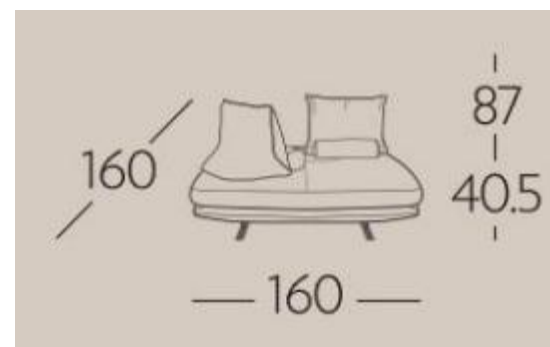
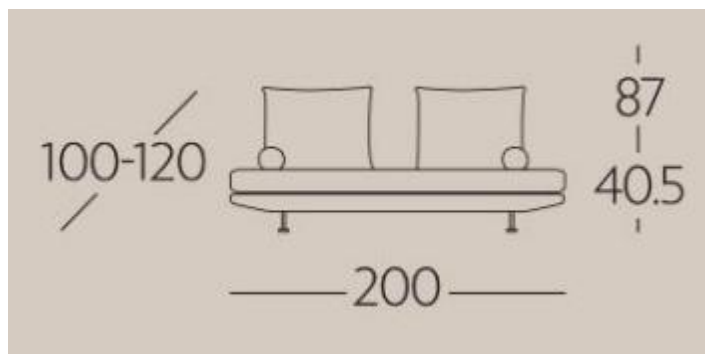
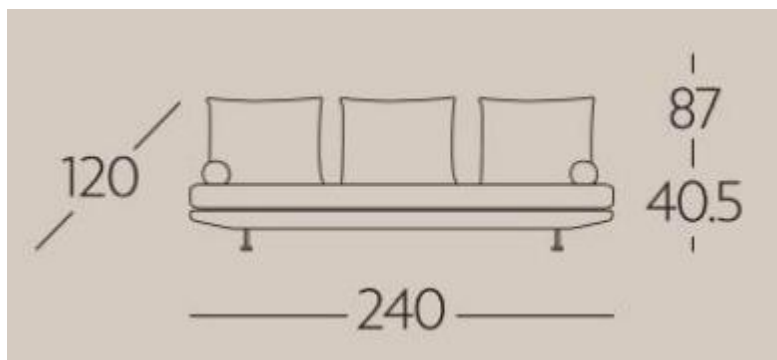

L-01系列

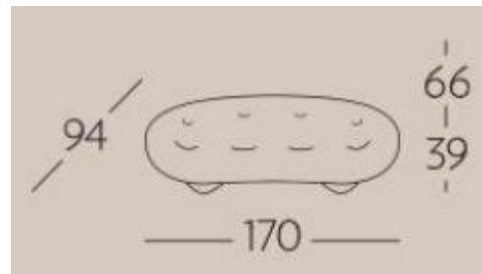
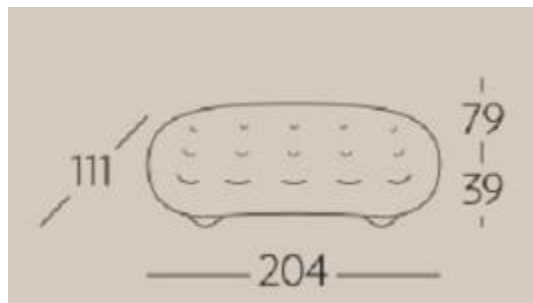
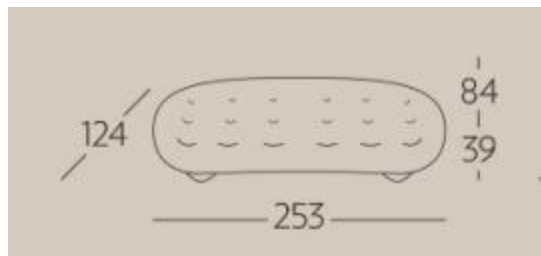

L-04L系列

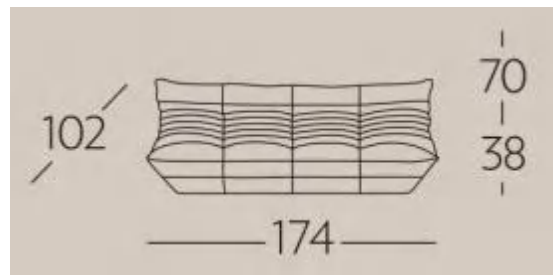
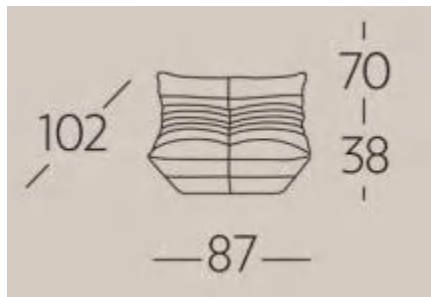

三人位2310\*1020\*700

L-04L系列



模块一单扶手带活动靠背尺寸：960\*960\*710

模块二尺寸：960\*600\*400

模块三无扶手带活动靠背尺寸：960\*960\*710



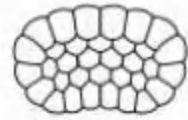

2.5-seat  
W. 190  
H. 76  
D. 114

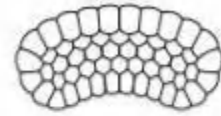

3 to 5-seat  
W. 238  
H. 76  
D. 114



Armchair  
W. 92  
H. 68  
D. 91



单人位: W1180\*D1120\*H740



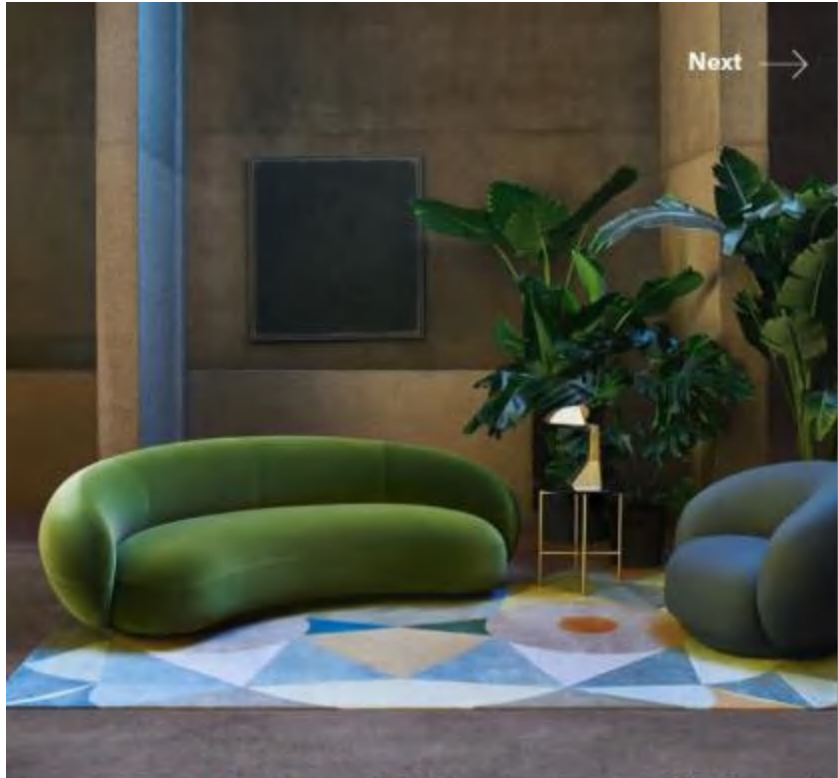

Sofa  
Cod. OJUL240  
W 240 D 126 H 75 cm  
H seat 42 cm









NELLA PAGINA ACCANTO\_OPPOSITE PAGE:  
FAT-FAT TAVOLINI\_SMALL TABLES















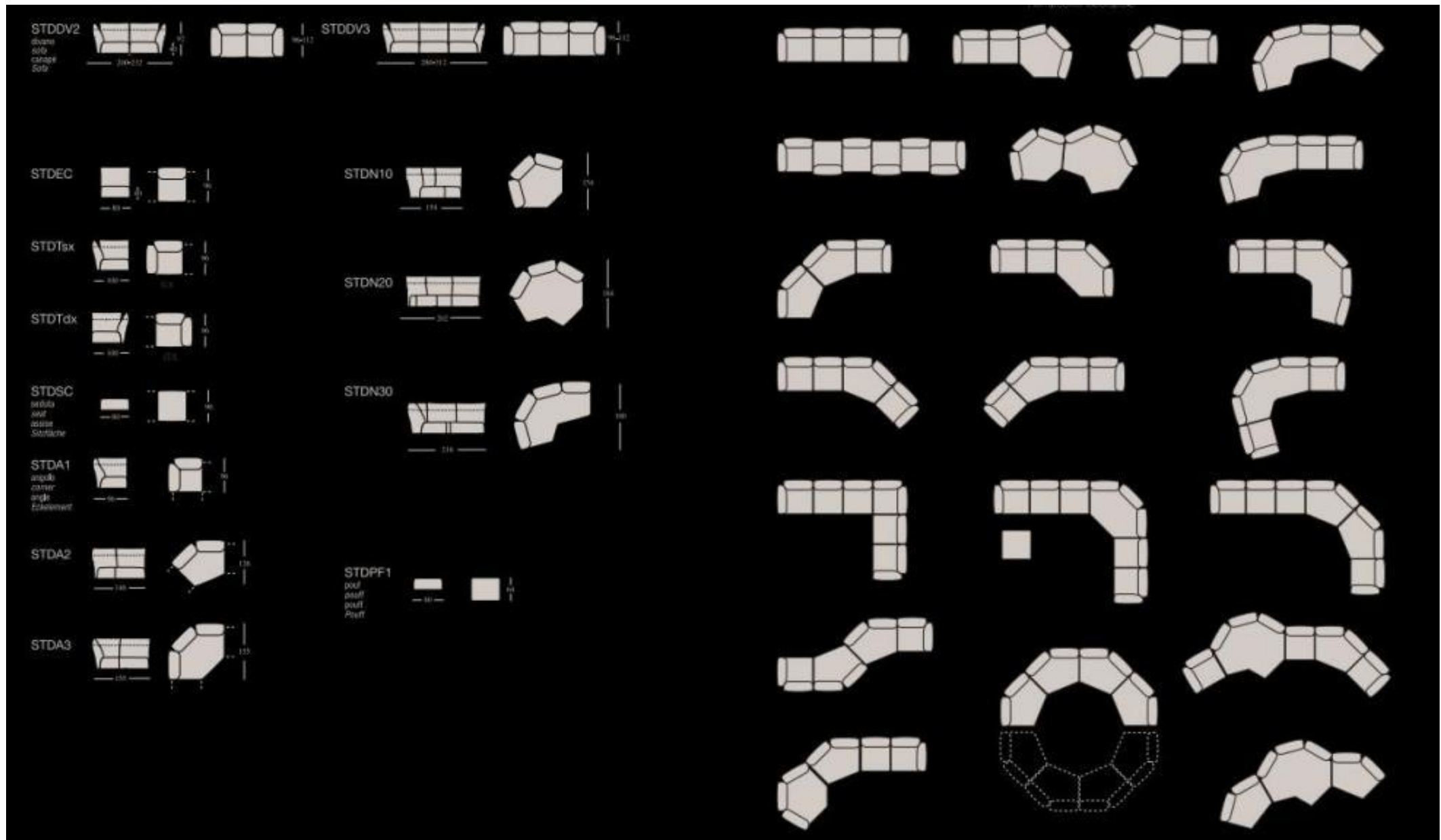

组合方式参考



OTRA  
OTRA  
OTR240  
divano  
sofa  
canapé  
Sofa

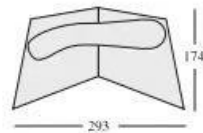

OTRA  
OTRA  
OTRB  
OTR320

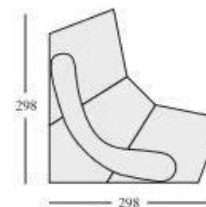

OTRA  
OTRA  
OTRB  
OTRCdX  
OTR240  
OTR320

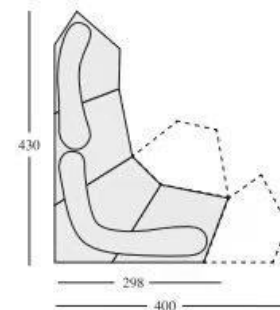

OTRA

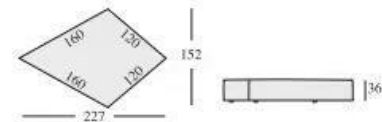

OTRB

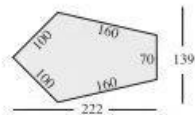

OTRCdX

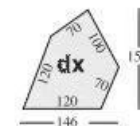

OTR240  
schienale  
back-rest  
dossier  
Rückenteil

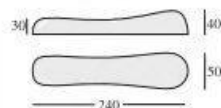

OTRCSx



OTR320







此款不同寻常的风格,出自其之手的座椅系列充满特立独行的个性,运用轻盈的线条勾勒出扶手椅(提供带扶手和不带扶手的版本)、休闲小扶手椅、围手椅、两座沙发、三座沙发和休闲凳。  
 设计师采用讽刺意味颠覆了座椅支撑脚的传统概念,此番设计的支撑脚像是主体的延伸,被放置在结构之外。  
 基壳的柔软弧面突显线条的精致感和温馨感,搭配精心设计的扶手和造型圆润的靠垫。

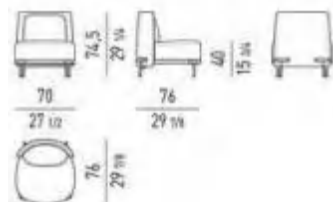
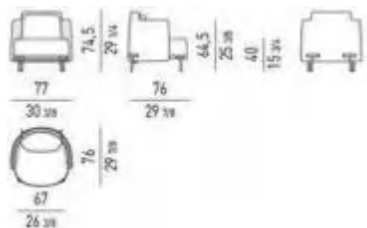

Structure Legs :金属腿:



金棕色艺术漆





实物拍摄:

尺寸:77\*D 76\*H 74.5

材质: 后背FAB.2 中国梦-01

坐垫及靠包FAB.1: MY-

A2976-

8

A 金棕色艺术漆金  
属脚





Material. 材质

这款扶手椅用现代方式重新演绎复古风情，展现capitonné钉扣工艺的传统。

座椅和靠背的设计将美学与人体工学巧妙地结合在一起：外壳采用热模塑的聚氨酯材料，内壳则采用模塑的高密度柔性聚氨酯。支撑底座采用洗练的设计，为其平添一份闲适的轻量感，其材质为模塑聚氨酯，漆面颜色为深Moka色。这是一款优雅舒适的扶手椅，可以和谐搭配该系列的所有沙发座椅，在各类环境中都能自如地展现魅力。

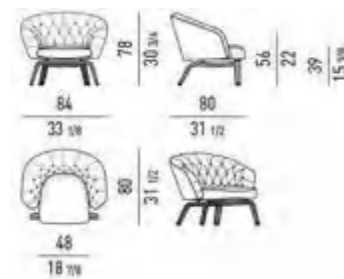

Mood Legs:木腿



黑色实木

实物拍摄：

尺寸：84\*80\*78H

材质：Cat. 2HS-BOXER-09

黑色实木腿





B009-P 单人沙发，全立面一体发泡， 内部羽绒填充，  
面料可选皮或者布。

Material.材质

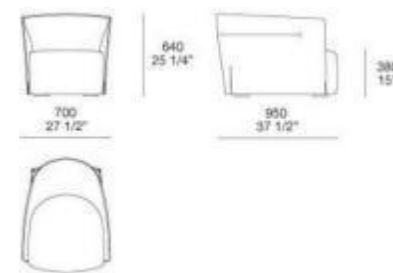





弯曲的木材和反光的金属：非凡的材质组合展现出恰如其分的优雅。

产品造型更加轻盈，并运用多种材质组合，打造温馨舒适的氛围。靠背为弧形胶合板，搭配米灰色鲍迪豆木饰贴面，内壳采用模塑

金棕色艺术漆，前方扶手椅的后方支撑部件为金属材质，表面为的高密度柔性聚氨酯。撑腿为米灰色的鲍迪豆实木材质

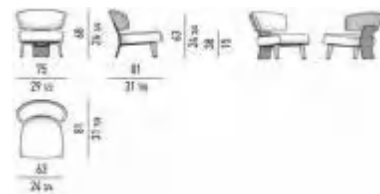

Material.材质

Structure Legs:金属腿

Legs/Backrest:腿/靠背



金棕色艺术漆



鲍迪豆木皮





座椅系列散发出50年代的风格，从别具魅力的环抱式扶手椅到用于休息区和餐厅的优雅小扶手椅，从围手椅到柔软的沙发，还有休闲凳，可谓兼容并蓄。复古线条的造型和极为精致的覆面使其充满新意，无论是座垫还是外层覆面，无论是织物还是皮革材质，均打造出优雅的氛围。



### Material.材质

Structure Legs :金属腿



黑色哑光漆

Wood Legs:木腿



黑色橡木

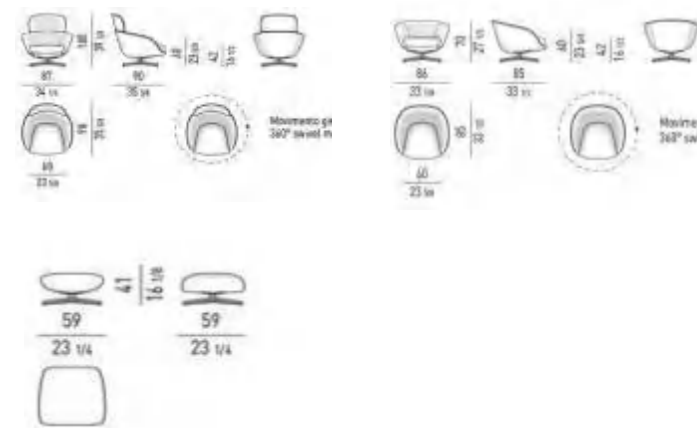

实物拍摄：

尺寸：86\*85\*70H

材质：Fab.1 MY-A2977-1A

Cat. 2HS-BOXER-02

黑色木包金属脚



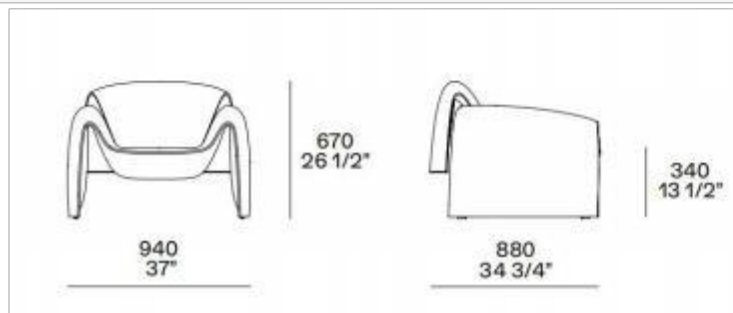

倒“V”形支撑结构造型，围绕扶手的衬垫以及宽大的座垫和靠垫赋予扶手椅一种即刻舒适、优雅和简约的感觉。



Material.材质

Mood Legs:木腿

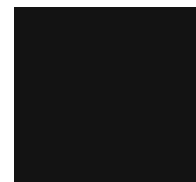

黑色橡木



## 细节照片

DETAIL PICTURE



引人注目的钢制支撑脚采用黑镍饰面,不仅是精致感的标志,也带来一份轻盈感。



### 实物拍摄

尺寸：69\*74\*74H

材质：Cat. 2 HS-BOXER-19

黑色橡木腿



其设计在美学上玩味不同材质的搭配创意，比如：用皮革来展现环抱式靠背的弧度及其延伸向下的扶手，用布料来突显靠垫的精致高定元素。沙发和扶手椅采用镀铬金属支撑脚，精益求精的细节突显其雅致的造型



Material.材质

Structure Legs :金属腿

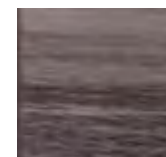

镜面镀铬

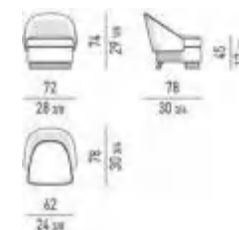
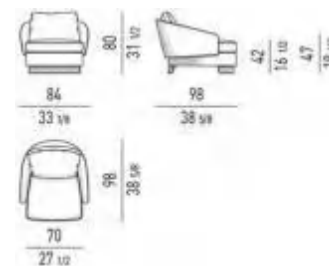





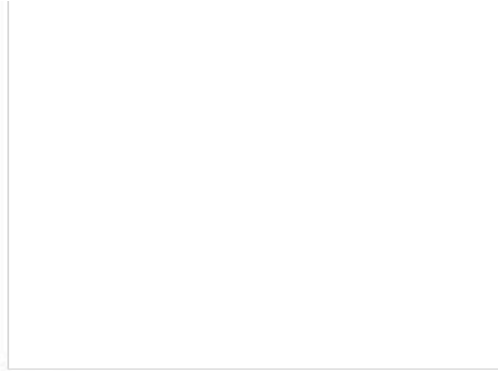

SOUPS\_8

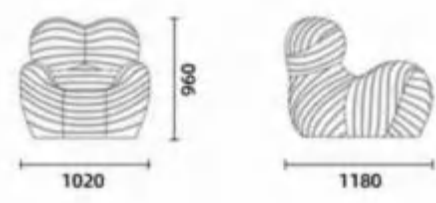

正交元素的并置 - 靠背和座椅在地面上相遇，扶手成为支撑 - 是 Utrecht 扶手椅的特征， 内部采用钢制支撑结构和锯齿缝线的内饰

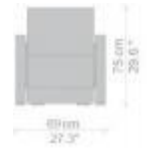



完美圆形扶手椅和旋转扶手椅旨在满足各种不同类型的功能和人体工程学要求。  
纤薄的靠背采用垂直绗缝和沿缓冲垫周边延伸的滚边,突显了工艺的高级定制品质。

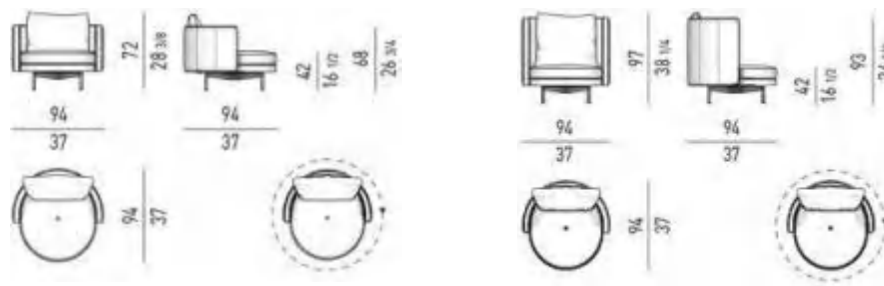

Material. 材质

Structure Legs :金属腿



金棕色艺术漆





此款休闲椅通过其流畅的造型和平衡的线条，探索不同类型更宽大舒适的扶手椅，突破经典造型风格，呈现创新解决方案。



Material. 材质

Mood Finish/legs .木扶手/腿 :







5571111

107 / 42"½

60 / 23"½

41 / 16"½



50 / 19"¾

93 / 36"¾



50 / 19"¾

86 / 33"¾

37,5 / 14"¾



37 / 14"¾



58 / 22"¾



坐墩，腿部喷涂石墨色艺术漆，面料可选皮 或者布



Material. 材质

Structure Legs : 金属腿



石墨色艺术漆

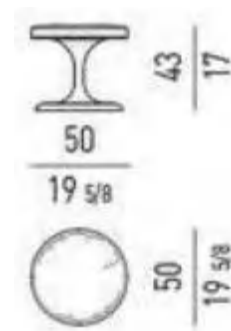



实物拍摄：

尺寸：直径500\*H 430

材质：FAB. 2: N H -

5  
0  
0  
5  
1  
-  
1  
1

腿部石墨色艺术漆



D016- B巴斯克



Material. 材质

Structure Legs :金属腿

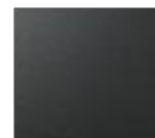

黑色哑光漆

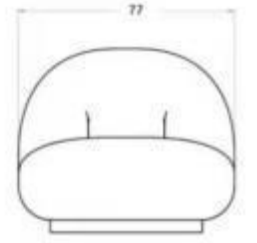

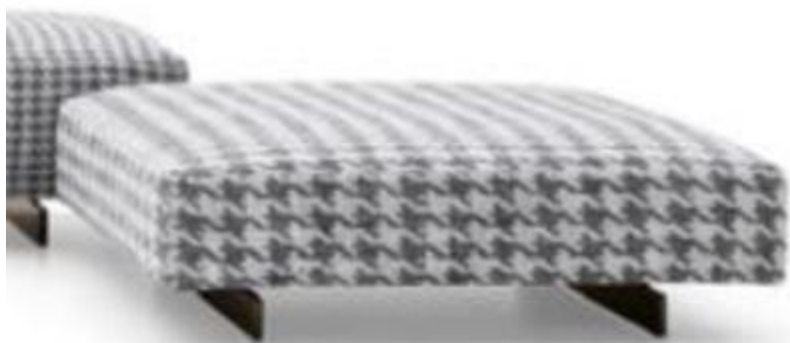

D009-M 坐墩，腿部喷涂金棕色艺术漆或哑光拉丝枪黑，面料可选皮或者布  
Material. 材质

Structure Legs :金属腿



不锈钢本色

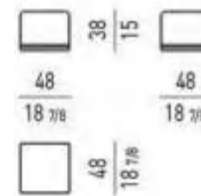



93 / 36<sup>1</sup>/<sub>2</sub>"

61 / 24"

50 / 19<sup>1</sup>/<sub>4</sub>"



95 / 37<sup>1</sup>/<sub>2</sub>"



90 / 35<sup>1</sup>/<sub>2</sub>"

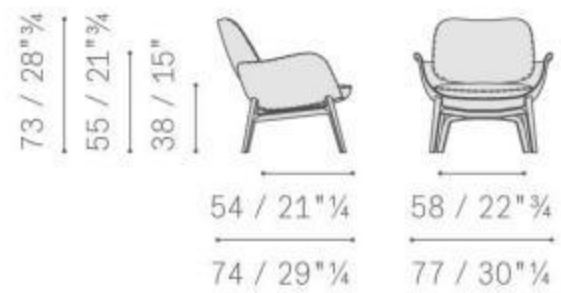

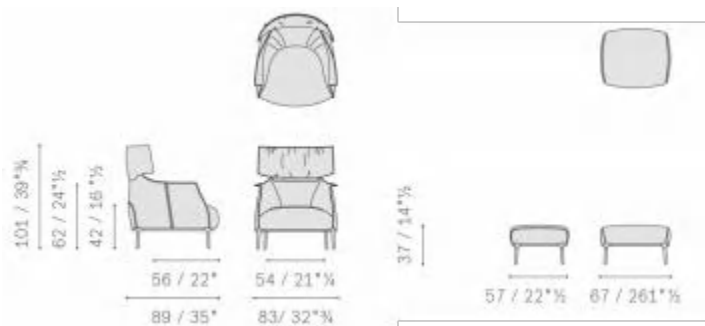

Archibald — Armchair

5506111

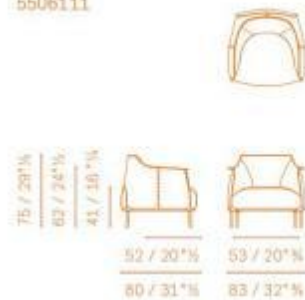







PF-06休闲椅710\*710\*710



PF-07A休闲椅560\*520\*750



尺寸：740\*930\*1030  
材质：实木+超纤/布艺



尺寸：730\*670\*720  
材质：实木+超纤/布艺



尺寸：730\*760\*810  
材质：实木+真皮/布艺

表面精妙浮现半圆形的支撑腿, 出人意料的视觉效果展现出创作者的风格巧思, 诠释出充满创新和惊喜的设计理念, 这一特质也体现在台面设计中, 无论是玻璃版本还是木质版本, 。

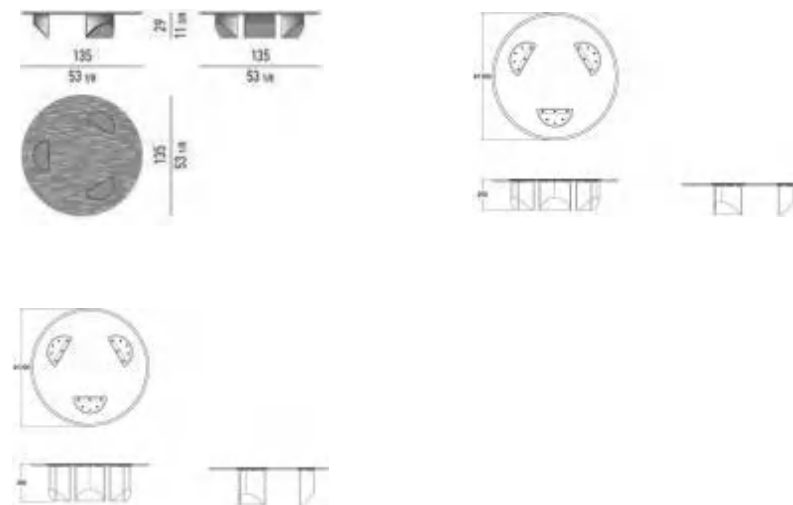

Material. 材质

Structure Legs :金属腿

Moood desktop: 木桌面



哑光拉丝枪黑



摩卡橡木



实物拍摄：

尺寸：120\*120\*38H

材质：面板：摩卡橡木贴皮

面板金属：不锈钢本色

腿：石墨色艺术漆

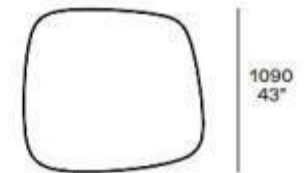
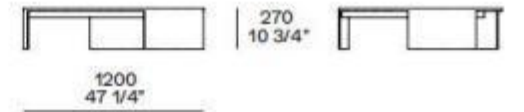
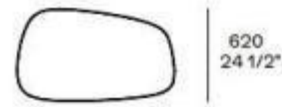
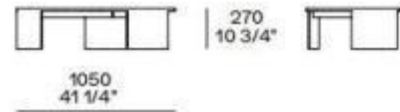



茶几，金属脚表面喷涂金棕色艺术漆，柜体摩卡橡木贴皮，桌面面板可选大理石。

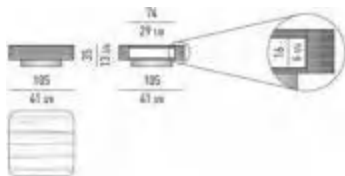
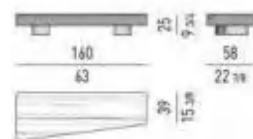
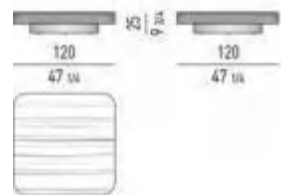

Material.材质

Structure Legs :金属腿

Moo d Cabinet:柜体

Marble desktop.大理石桌面 :



金棕色艺术漆



摩卡橡木



金纹爵士白



实物拍摄：

尺寸：120\*120\*25H

材质：面板：金纹爵士白

柜体：摩卡橡木

腿：金棕色艺术漆







C001-P 茶几，茶几面板为熏黑橡木山纹，腿为熏黑色实木。

Material. 材质

Mood. 木材 :



黑色橡木

C001-P185/1000

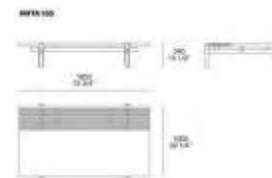

C001-P140/760

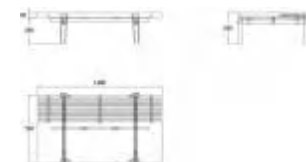

C001-P120/120

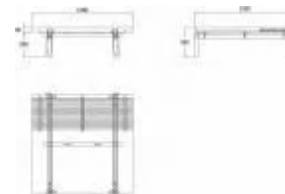





轻盈的金属结构搭配正交线的设计，咖啡桌还具有与座椅相同的结构风格细节，视觉中心的通透空间十分引人注目，打造出空间感和轻盈效果。



C024-M 500

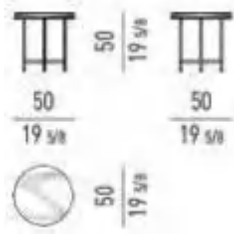

C024-M90

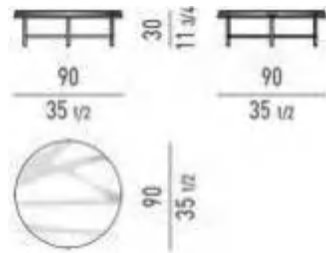

Material.材质

Structure Legs :金属腿

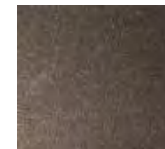

金棕色艺术漆

Marble desktop. 桌面

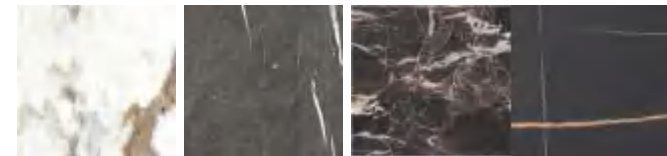

金纹爵士白

啡慕斯

进口啡网

劳伦黑金





轻盈的金属结构搭配正交线的设计，在不同位置插入大圆环。除了打破造型轮廓的几何规则之外，根据边几的大小，圆环变成连接或支撑部件。圆环中心的通透空间十分引人注目，打造出空间感和轻盈效果。



C006-M55



C006-M90

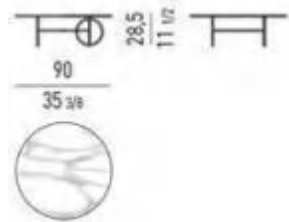

Material.材质

Structure Legs :金属腿



金棕色艺术漆

Marble desktop. 桌面



金纹爵士白

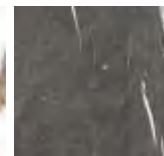

啡慕斯

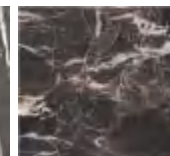

进口啡网

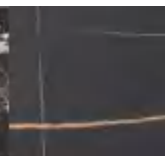

劳伦黑金



咖啡桌的特点是简洁的线条和与座椅相同的突出钢脚， 以现代方式重新诠释了七十年代早期的体积和设计标志。



C023-M 500

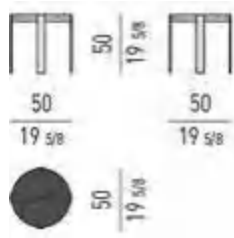

C023-M90

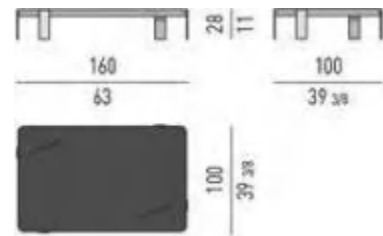

Material.材质

Structure Legs :金属腿



镜面枪黑

Marble desktop. 桌面



金纹爵士白



啡慕斯



进口啡网

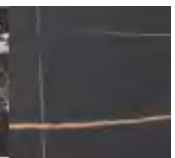

劳伦黑金





结构的简约设计为咖啡桌系列增添了现代魅力，抛光浅金，以其优雅的光泽，与玻璃桌面形成强烈视觉冲击。

Material.材质

Metal.金属：

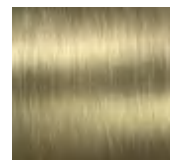

镜面香槟金

Legs: 腿：



酒红亮光烤漆



米白亮光烤漆



结构的简约设计为咖啡桌系列增添了现代魅力，抛光浅金，以其优雅的光泽，为任何环境引入精致的装饰。

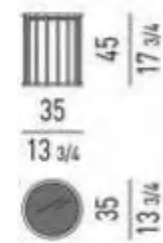

Material.材质

Metal.金属：

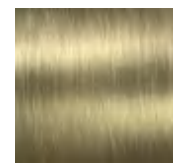

镜面香槟金







C005-M 边几，全金属材质，面板及底座表面喷涂石墨色艺术漆。

Material.材质

Metal.金属：



石墨色艺术漆

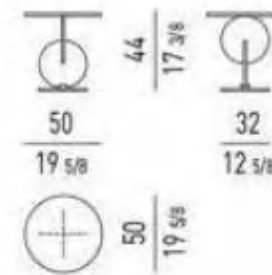



实物拍摄：

尺寸：直径50\*44H

材质：面板：金棕色艺术漆

腿：金棕色艺术漆





B007-M 边几，金属脚表面喷涂石墨色艺术漆，面板可选理石桌面或烤漆。

Material.材质

Structure Legs :金属腿

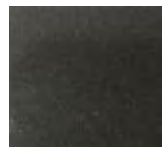

石墨色艺术漆

Paint desktop. 烤漆桌面：



米白亮光烤漆 大象灰烤漆



Marble desktop. 理石桌面：



金纹爵士白 啡慕斯 进口啡网 劳伦黑金



**KOISHI**  
Design Jean-Marie Massaud

Struttura in metallo verniciato brunito o champagne opaco. Piano in olmo nero, rovere gold, vetro blu riflettente, pietra ebano spatolata o sei marmi levigati e sei lucidi.

Structure in metal painted brunito or mat champagne. Top in black elm, gold oak, blu reflecting glass, ebony stone with spatula finish or six mat and six glossy marbles.

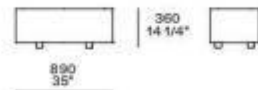
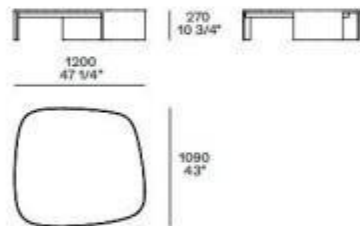
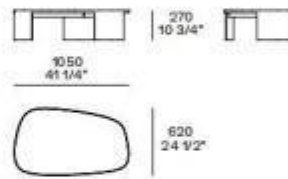
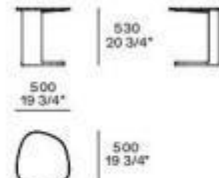
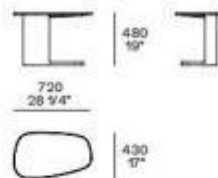

Da utilizzare tra due elementi del divano.  
To be inserted between two sofa units.



## ORBIT

Design Jean-Marie Massaud

Piano e struttura in vetro bronzato, struttura in vetro soffiato.

Top and structure in bronzed glass, structure in blown glass.

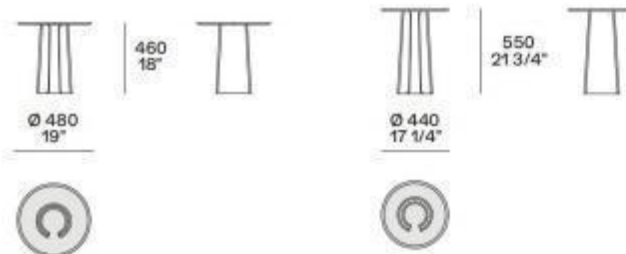



实物拍摄：  
尺寸：直径55\*53H  
材质：面板：爵士白金纹  
腿：金棕色艺术漆

是用于收纳贵重物品的边几系列，拥有纯粹而简洁的美学设计，有着精美绝伦的多种材质组合。这一边几家族拥有华贵的美学特质，因而也有着非同一般的功能，在提供实用置物表面的同时，呈现精美的装饰效果，具有50年代和60年代的米兰设计风格。

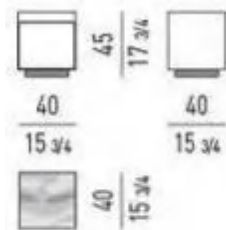

#### Material.材质

Metal.金属： Mood. 木材内框架：

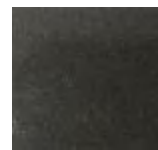

石墨色艺术漆



冷灰色烤漆

Marble desktop. 理石桌面：



金纹爵士白



啡慕斯



进口啡网



劳伦黑金





M-154 茶几，金属脚喷涂金棕色艺术漆，桌面摩卡橡木贴皮或亮光烤漆，大理石。



Material.材质

Structure Legs :金属腿



金棕色艺术漆

Marble desktop. 大理石 :



金纹爵士白

Moo d desktop.木桌面



摩卡橡木

M-154

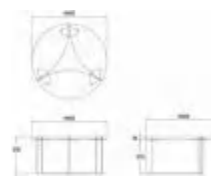

M-154

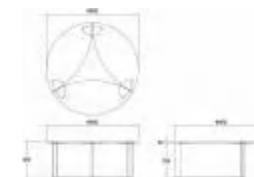

M-154

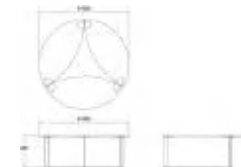



尺寸：直径1200\*430H

直径900\*360H

直径600\*300H

材质：面板：摩卡橡木贴皮

腿：金棕色艺术漆

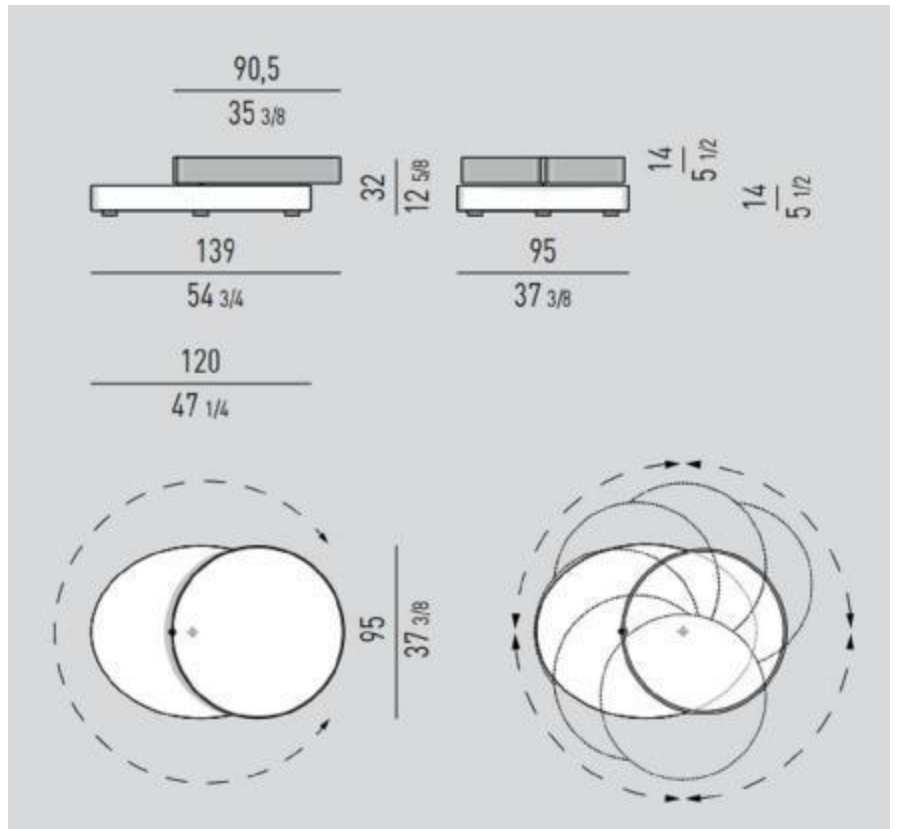



M-103C茶几，腿部为摩卡橡木实木腿，桌面可选大理石或亮光烤漆面板。

### Material. 材质

Moo d Legs.木腿 : Paint desktop. 烤漆桌面 :



摩卡橡木



酒红色亮光漆



米白亮光烤漆



大象灰烤漆

Marble desktop. 理石桌面 :



金纹爵士白

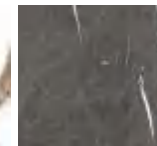

啡慕斯



进口啡网



劳伦黑金



32 / 12<sup>1</sup>/<sub>4</sub>"

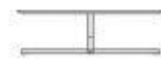

110 / 43<sup>1</sup>/<sub>4</sub>"

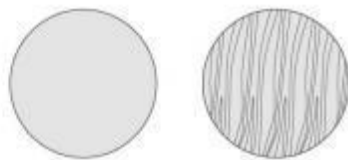

32 / 12<sup>1</sup>/<sub>4</sub>"



80 / 31<sup>1</sup>/<sub>4</sub>"



43 / 17"



60 / 23<sup>1</sup>/<sub>2</sub>"



52 / 20<sup>1</sup>/<sub>4</sub>"



46 / 18"





35 / 13"

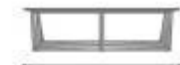

130 / 51"



130 / 51"



35 / 13"



110 / 43"



110 / 43"



47 / 10"

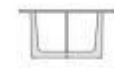

80 / 31"

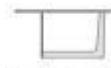

80 / 31"



45 / 17"



53 / 20"



53 / 20"





P-43C



P-44C



P-45C



P-46C



P-47C



P-48C



P-49C



P-50C



P-51C



P-52C

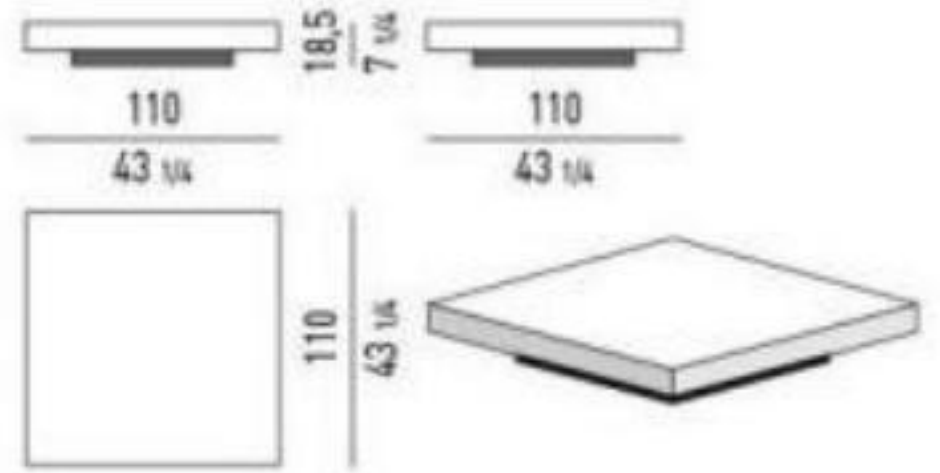



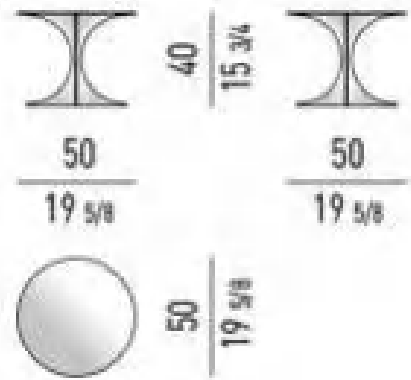



HL-1200A

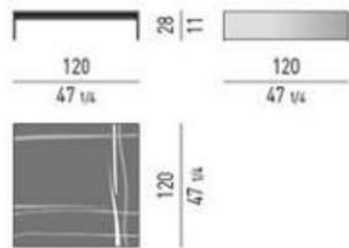



420\*480\*420MM



D920\*440MM

D500\*490



尺寸：265\*260\*450



尺寸：430\*450



尺寸：小340\*450  
大440\*530

桌子的整个体积似乎变得失重，轻轻靠在腿尖上，挑战万有引力定律。  
 精致的造型设计是通过半圆形的翅形撑腿变形变成鸡的效果，与感性形成鲜明的对比，从而通过巧妙的形切斜设计来能够实现。



### Material.材质

Structure Legs :金属腿

Moo d desktop. 木桌面



石墨色艺术漆

哑光拉丝枪黑

摩卡橡木

Marble desktop. 理石桌面 :

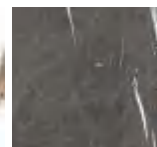

金纹爵士白

啡慕斯

进口啡网

劳伦黑金

M-164 160

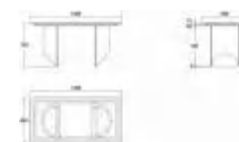

M-164 240



M-164 200



M-164 220







**Material.材质**

Structure Legs :金属腿

Moo d desktop. 木桌面



石墨色艺术漆



摩卡橡木

Marble desktop. 理石桌面 :



金纹爵士白

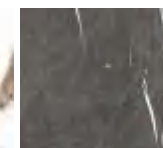

啡慕斯



进口啡网



劳伦黑金

M-165 160

M-165 180

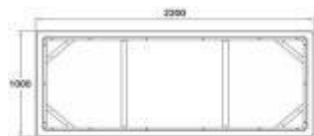
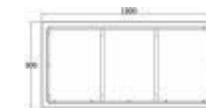
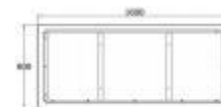

M-165 220





实物拍摄：

尺寸：240\*120\*75H

材质：面板：摩卡橡木

腿：石墨色艺术漆





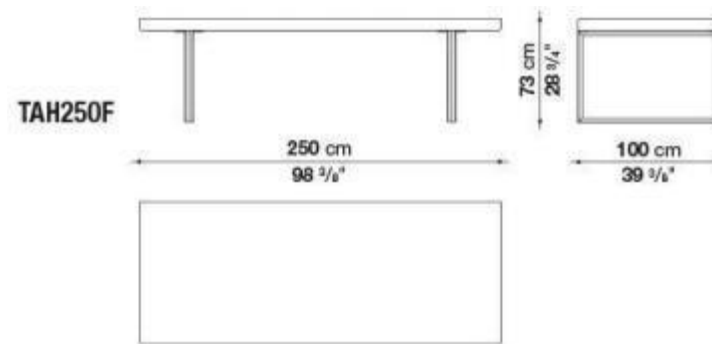

Material. 材质

Structure Legs :金属腿

Wood desktop. 木桌面



金棕色艺术漆



摩卡橡木

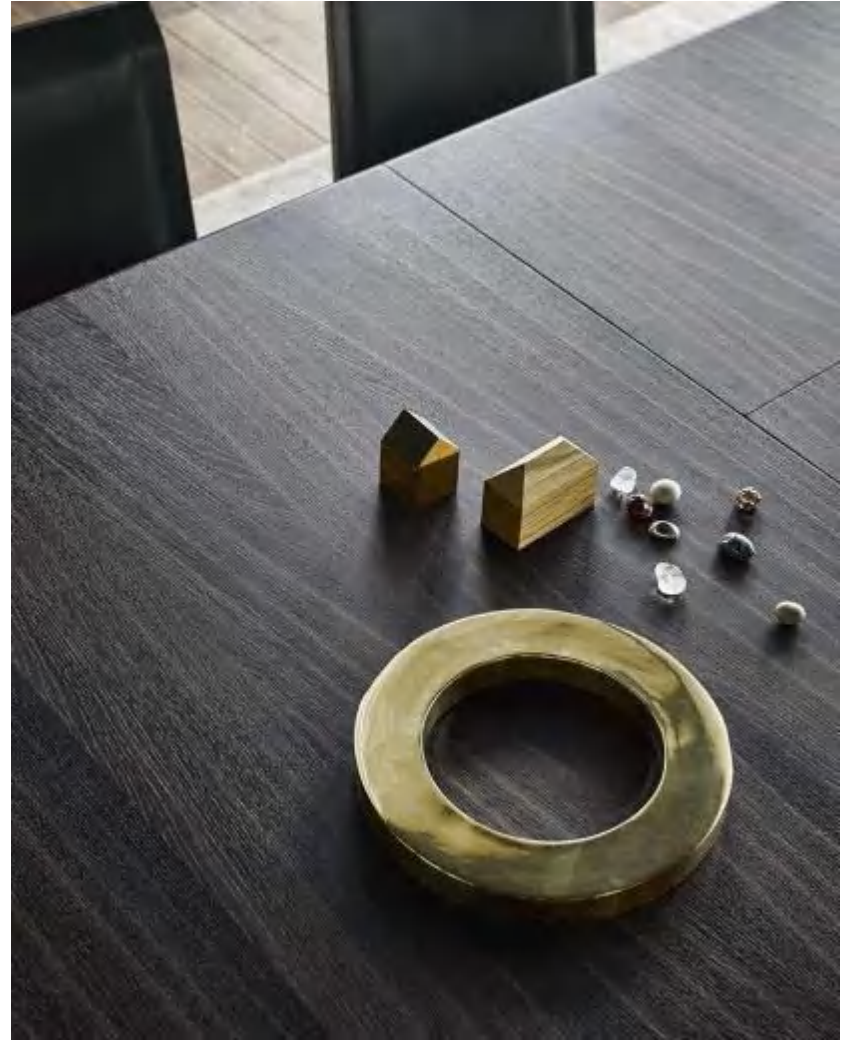



75 / 29 1/2



110 / 43 1/4

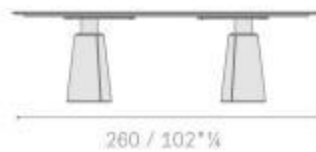

260 / 102 3/4



C019-P 餐桌，餐桌腿部为摩卡橡木，面板可选大理石或玻璃

Material. 材质

Moo d Legs. 木腿



摩卡橡木

Marble desktop. 理石桌面：

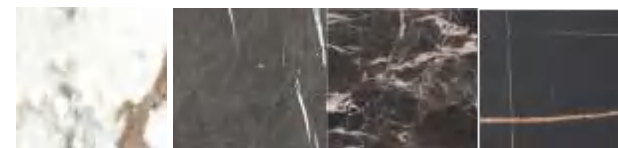

金纹爵士白

啡慕斯

进口啡网

劳伦黑金

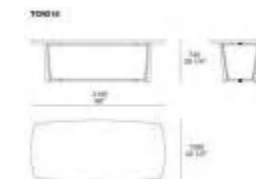
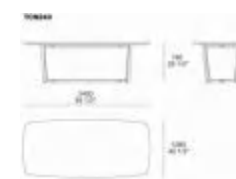





尺寸：2500\*1100\*750  
2100\*1100\*750



尺寸：W2600\*D1200\*H750



W2200\*D1000\*H750  
W2400\*D1200\*H750

餐桌，腿部拉丝香槟金和黑色哑光漆金属，桌面 可选大理石或摩卡橡木面板。

Material. 材质 Structure

Legs :金属腿

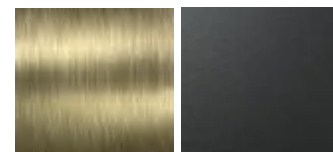

拉丝香槟金 石墨色哑光漆

Marble desktop. 理石桌面 :



金纹爵士白

啡慕斯

进口啡网

劳伦黑金

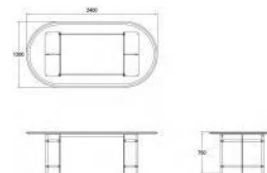





实物拍摄：

尺寸：240\*120\*75H

材质：面板：劳伦黑金大理石

腿：拉丝香槟金，黑色哑光漆

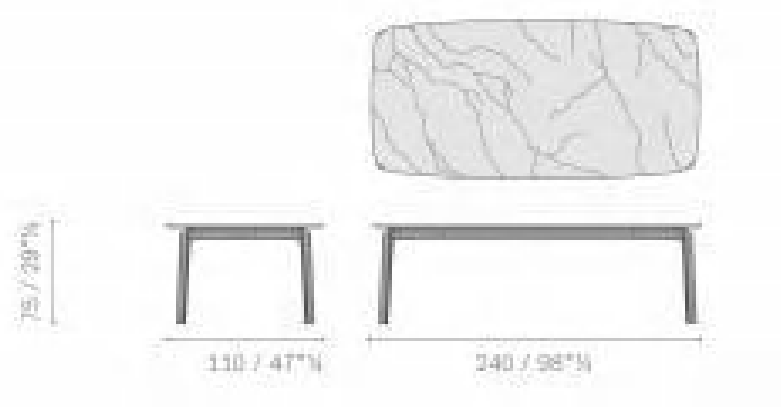
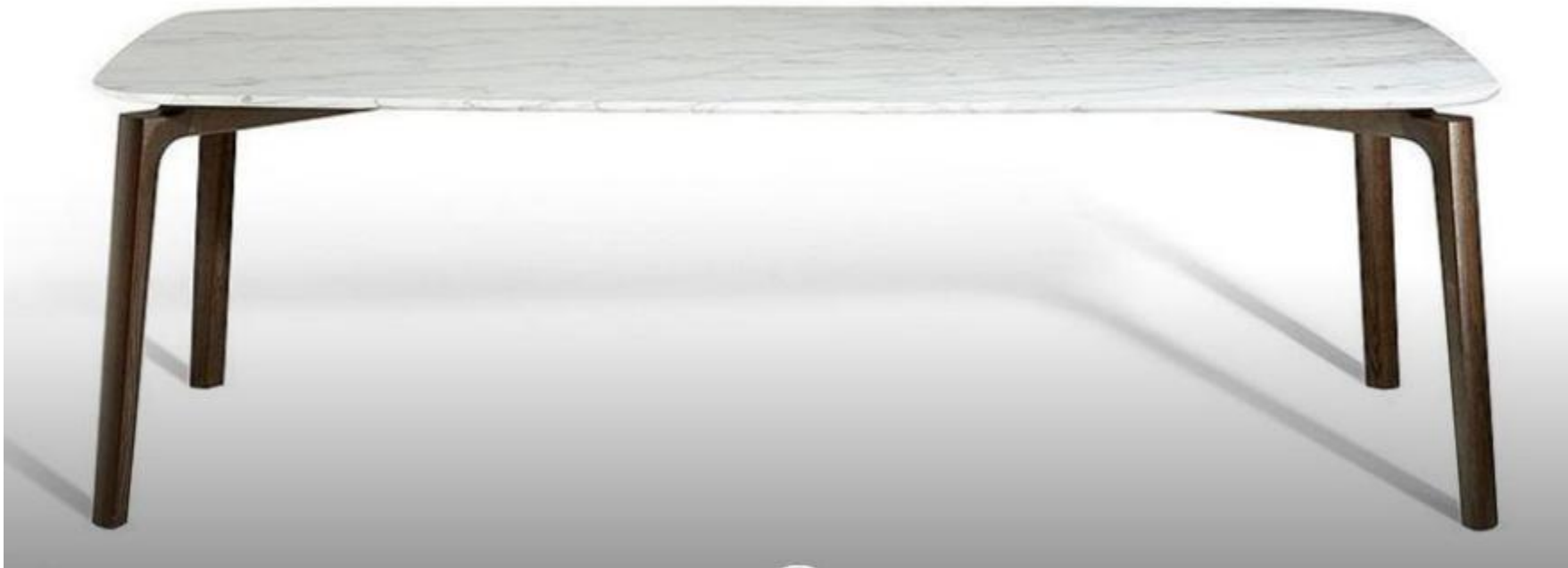

W1800\*D1000\*H750  
W2000\*D1000\*H750  
W2200\*D1000\*H750  
W2400\*D1100\*H750



W2000\*D1050\*H750  
W2200\*D1150\*H750  
W2400\*D1150\*H750

M-167D

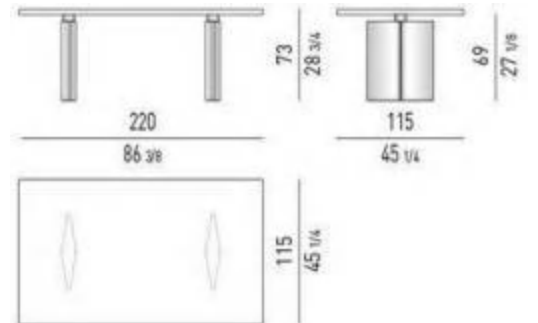



Table - Oracle in Nero White marble top with Lazy Susan top, top grey base.

Table - Oracle piano in Nero White marble top with Lazy Susan, base top grey.



Struttura in legno - Bubble  
Bubble structure glass top  
white glass top transparent,  
structure structure.

Chaise - Oracle - D&B Crest  
SROBROE with A Butler  
structure in leather Pelle Plus  
4022, with D Bover structure  
and top in leather Pelle Plus  
4022.

Legno piano e trasparente -  
Bubble Bubble with structure  
in bianco e trasparente,  
struttura struttura.

Legno - Oracle - D&B Crest  
SROBROE with A Butler  
structure in leather Pelle Plus  
4022, with D Bover structure  
and top in leather Pelle Plus  
4022.

Chaise - Douglas piano

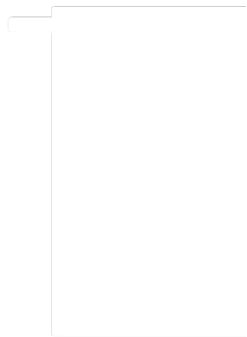

桌子以50、60年代为设计灵感，酒杯状锥形支架与底座和谐相融。桌子支架采用聚氨酯制成，这种材料虽轻盈却牢固，表面极为光滑，台板以圆形、方形及矩形三种造型呈现，搭配柔和转角，有多种型号可选。



Material. 材质

Structure Legs :金属腿

Moo d desktop. 木桌面



石墨色艺术漆



摩卡橡木

Marble desktop. 理石桌面 :



金纹爵士白

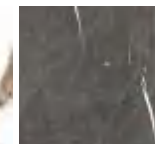

啡慕斯



进口啡网



劳伦黑金

M 169D 140

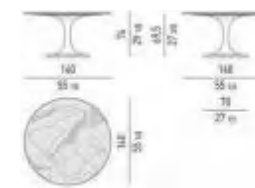

M- 169 160

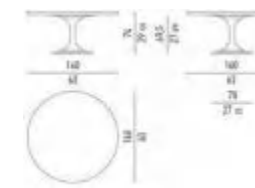



非凡的优雅和起伏的形状将摩根大理石餐桌带到了新的高度。

以现代氛围重新诠释，并以精美的大理石等华丽奢华的材料加以增强，自信地融入精致时尚的环境，与室内系列中的许多互补单品建立了融洽的对话。



### Material. 材质

Moo d Legs :木腿



石墨色艺术漆

Moo d desktop. 木桌面



摩卡橡木

Marble desktop. 大理石桌面：

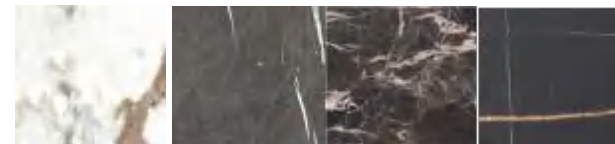

金纹爵士白

啡慕斯

进口啡网

劳伦黑金

M 1 6 5 A 160

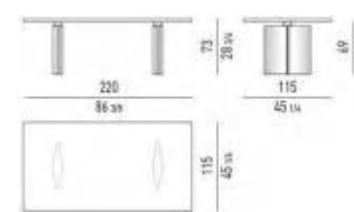
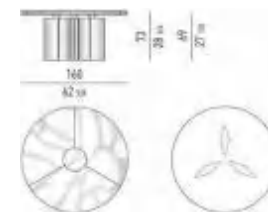



尺寸D1800\*750  
D1600\*750





75 / 29\*½



120 / 47\*¼



120 / 47\*¼



75 / 29\*½

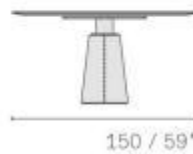

150 / 59\*



150 / 59\*

79 / 31\*  
75 / 29\*½

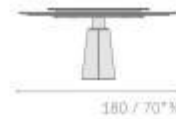

180 / 70\*¾

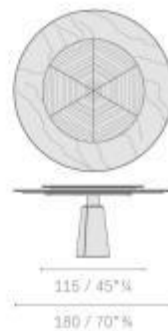

115 / 45\*¼  
180 / 70\*¾

桌子的整个体积似乎变得失重，轻轻靠在腿尖上，挑战万有引力定律。  
 精致的造型设计是通过半圆形的翅形撑腿变形变成鸡的效果，与感性形成鲜明的对比，从而通过巧妙的形切斜设计来能够实现。



M 1 6 3 160

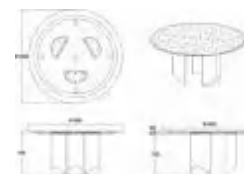

M - 1 6 3 135



### Material.材质

Structure Legs :金属腿

Moo d desktop. 木桌面



石墨色艺术漆



哑光拉丝枪黑



摩卡橡木

Marble desktop. 理石桌面 :



金纹爵士白

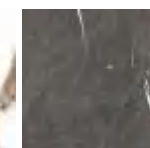

啡慕斯

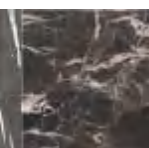

进口啡网

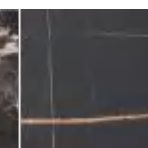

劳伦黑金



实物拍摄：

尺寸：直径160\*75H

材质：面板：爵士白金纹大理石

腿：石墨色艺术漆

座椅呈现出精致的设计感，拥有与同名扶手椅一样的环抱式造型。得益于金属框架和聚氨酯泡沫的应用，这一座椅将优雅的造型和绝佳的舒适感和谐地融合在一起。靠垫采用热塑成型材料和聚氨酯泡沫制成，进一步提升靠背的舒适度。



Material. 材质

Structure Legs :金属腿

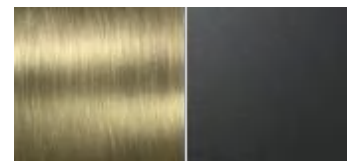

镜面香槟金 黑色哑光漆

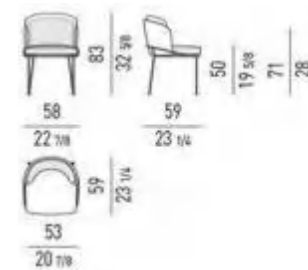



实物拍摄:

尺寸: 58\*59\*H 81

材质: 靠包 cat. 2HS-BOXER-17

坐垫及靠背 FAB. 1: MY-

A2842-

10A

黑色哑光漆金属脚





这是一款造型流畅的座椅，将优雅的造型与舒适感融合在一起。柔软的坐垫搭配线条修长的支撑腿，

Material. 材质

Mood Leg. 木材腿

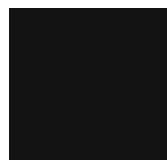

熏黑色实木

M-167F

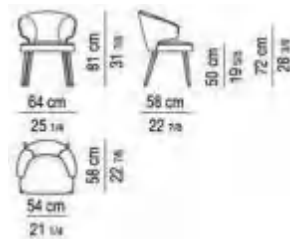

M-167

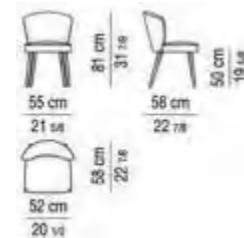



实物拍摄:

尺寸: 64\*58\*H 81

材质: FAB. 1: N H -

5

7

0

9

1

4

5

熏黑色实木腿



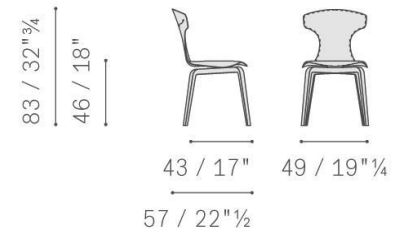
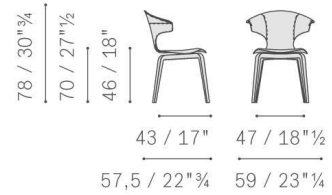

尺寸：扶手610\*580\*790  
 无扶手510\*570\*820  
 材质：实木+马鞍皮



餐桌椅拥有精巧的比例和绝佳的舒适性，其设计严谨，恰如其分，经典的线条使其可以完美搭配造型各异的餐桌。  
这款餐桌椅有两个版本可供选择：带扶手或者不带扶手；  
在带扶手的版本中，侧方支架结构被精心设计成扶手，考究的部件使木质结构倍显精致，衬垫搭配皮革覆面，提供更好的舒适性，同时也展现了制作的精湛工艺



Material. 材质

Mood Finish/legs .木扶手/腿：



熏黑色实木

M-168



M - 1 6 8 F

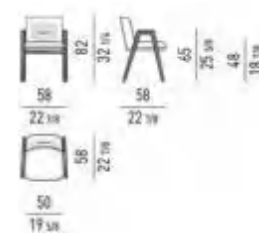



实物拍摄:

尺寸: 50\*58\*H 82

材质: FAB. 1: N H -

5

0

1

1

5

-

1

4

熏黑色实木腿



此系列餐椅通过其流畅的造型和平衡的圆润线条，探索不同类型的沙发座椅组合，从休闲的小扶手椅、更宽大舒适的扶手椅到沙发，突破经典造型风格，呈现创新解决方案。



Material. 材质

Mood Finish/legs .木扶手/腿 :



熏黑色实木

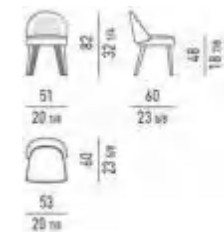



实物拍摄:

尺寸: 62\*60\*H 82

材质: 靠背外侧cat.2HS-BOXER-11

坐垫及靠背FAB.1: MY-

A2940-

13A

熏黑色实木腿





M-169餐椅，腿部为黑色哑光金属，面料可选皮 或者布

Material. 材质

Structure Legs :金属腿

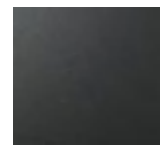

黑色哑光漆

M-169

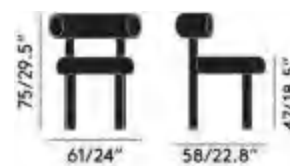

M-172





实物拍摄：

尺寸：61\*58\*H75

材质：FAB. 1：MY-  
A2267- 1A

黑色哑光漆金属腿



实物拍摄：

尺寸：55\*55\*H 101

材质：FAB. 1：N H -

7  
5  
2  
5



这是一款造型流畅的座椅，将优雅的造型与舒适感融合在一起。柔软的坐垫搭配线条修长的支撑腿，

Material.材质

Structure Legs :金属腿

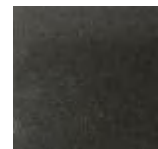

石墨色艺术漆

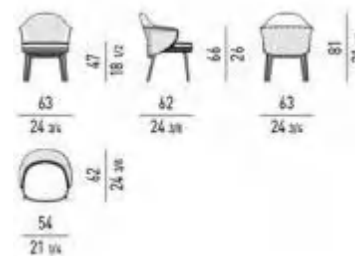





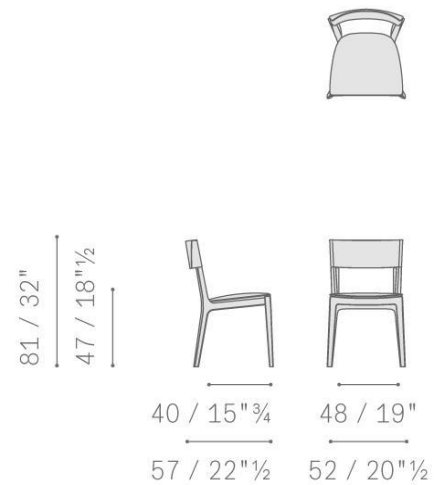
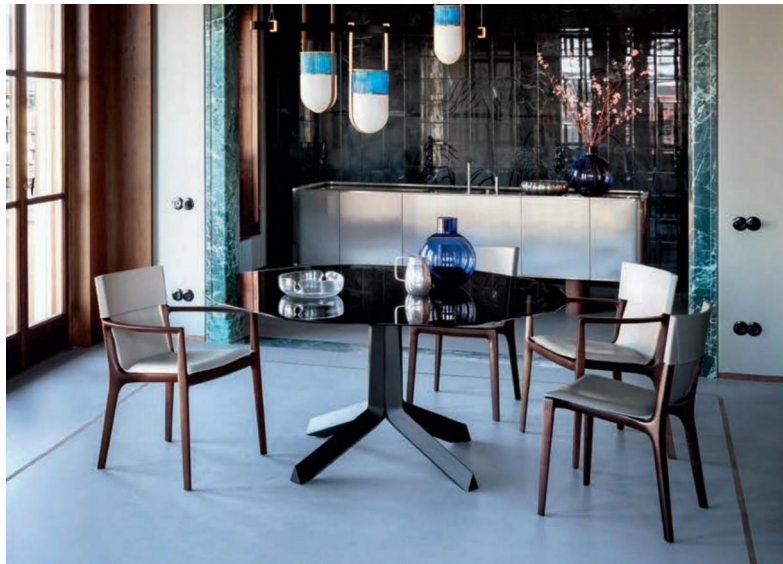
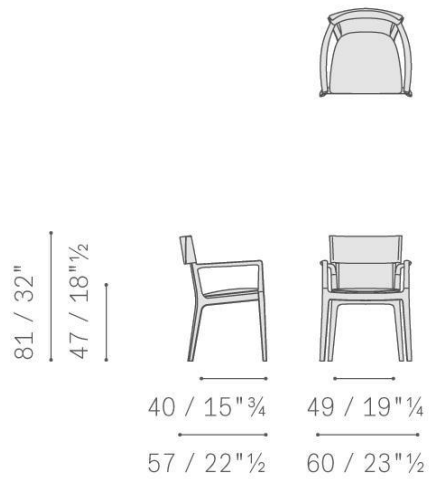



630  
24 3/4"

780  
30 3/4"



600  
23 1/2"

480  
19"



W610\*D610\*H790

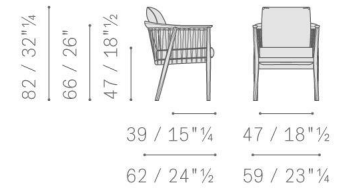
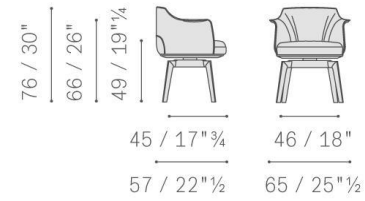
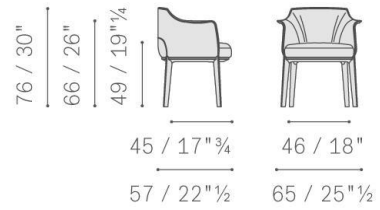

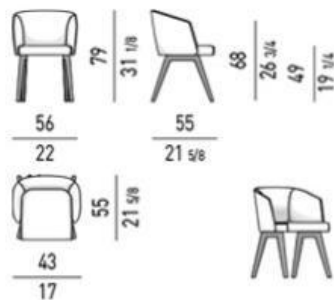
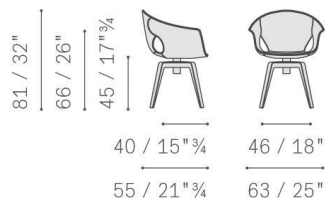

660\*570\*830MM

550\*600\*840MM

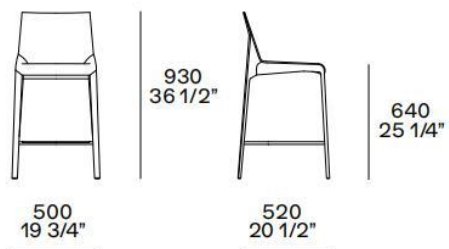
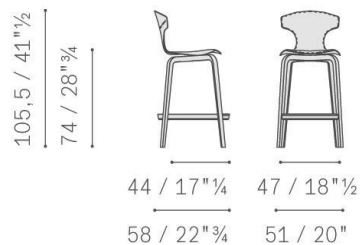

460\*580\*880MM

460\*500\*1010MM  
坐高: 750MM



尺寸：扶手610\*550\*790  
无扶手610\*550\*790  
材质：实木+真皮/布艺



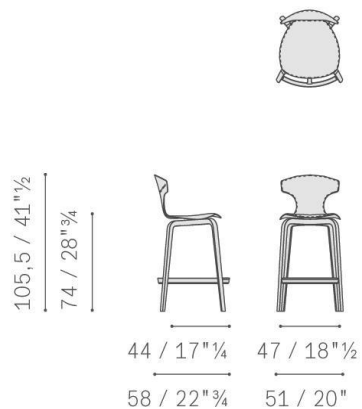

460\*580\*880MM

460\*500\*1010MM  
坐高: 750MM





尺寸：550\*560\*810  
材质：实木+超纤/布艺



尺寸：550\*560\*810  
材质：实木+超纤/布艺



尺寸：640\*590\*795  
材质：实木+超纤/布艺



尺寸:500\*500\*830

材质: 实木+超纤/布艺



尺寸：590\*600\*935  
材质：实木+真皮/布艺





尺寸：580\*590\*865  
材质：实木+真皮/布艺



尺寸：扶手520\*570\*810  
无扶手450\*530\*810  
材质：实木+编藤



尺寸：520\*570\*780  
材质：实木+马鞍皮







尺寸：600\*540\*845  
材质：实木+超纤/布艺

尺寸：扶手550\*550\*795  
无扶手560\*550\*780  
材质：实木+布艺/超纤





尺寸：扶手530\*575\*800  
无扶手470\*570\*800  
材质：实木+编藤



尺寸：扶手620\*640\*930  
无扶手620\*640\*930  
材质：实木+超纤+布艺



尺寸：扶手610\*560\*880  
无扶手560\*560\*880  
材质：实木+真皮/布艺



尺寸：扶手550\*550\*820  
无扶手550\*550\*820  
材质：实木+真皮+布艺



尺寸：615\*605\*795  
材质：实木+真皮

尺寸：710\*550\*735  
材质：实木+编藤





尺寸：515\*600\*850  
材质：实木+真皮

尺寸：560\*500\*745  
材质：实木+多层板







尺寸：590\*540\*760  
材质：实木+超纤皮



尺寸：445\*515\*735  
材质：实木+牛皮纸编藤



尺寸：610\*560\*790  
材质：实木+牛皮纸编藤



尺寸：590\*590\*750  
材质：实木+布艺



尺寸：480\*590\*820

材质：实木+马鞍皮



尺寸：630\*540\*765  
材质：实木+真皮/布艺



床头采用皮革包覆，靠包采用与床框同样的面料。  
 靠垫通过华贵的皮革绑带固定在床头，睡床搭配精致镜面枪黑支撑脚。



Material. 材质

Structure Legs :金属腿

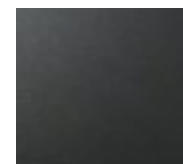

镜面枪黑

Back. 后背



硬皮 (LZ-PAN-10A)

M-01M

M-01L



M-01S

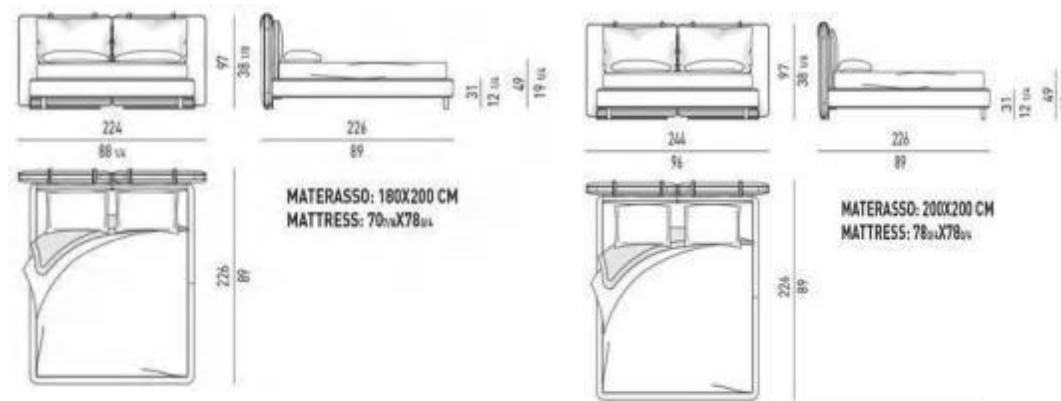





床用现代方式重新演绎经典风情，呈现平衡的比例，拥有丰富的覆面细节，展现出工厂精湛的加工技艺。

床头靠板内含填充物，提供一体式版本和两件式版本，有两种高度和三种宽度可供选择， 以此打造对称和非对称的配置，另外还可以搭配不同的覆面。

床头的覆面完全可以拆下，精细的缝线使其备显考究， 图形充满现代感。



Material. 材质

Structure Legs :金属腿



金棕色艺术漆

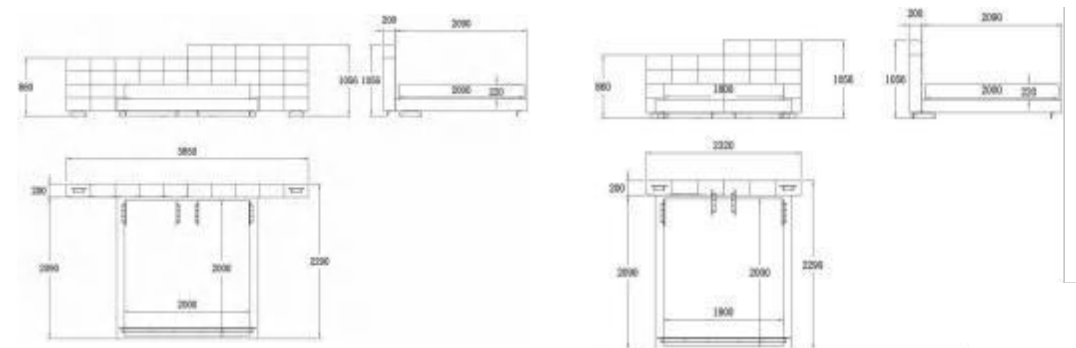



实物拍摄:

尺寸: 388\*229\*H98/105

材质: 后背皮 cat. 3HS-10103

后背及床箱 FAB. 1: MY-  
A2977- 1A

金棕色艺术漆金属脚







M-04双人床，腿部及靠背摩卡橡木色实木，靠背及床箱可选皮或者布

Material. 材质

Moood Legs.木腿：



摩卡橡木









M-05双人床，腿部为镜面枪黑色金属，靠背及床箱  
可选皮或者布

Material. 材质

Structure Legs :金属腿

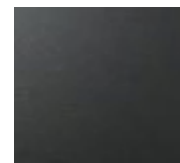

镜面枪黑

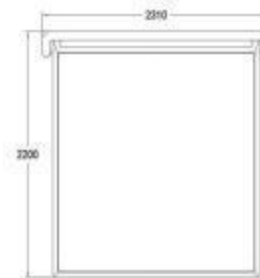
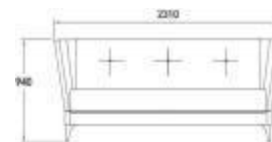
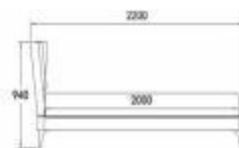
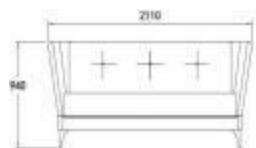
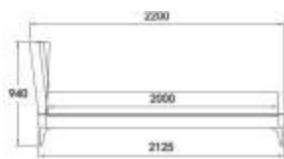
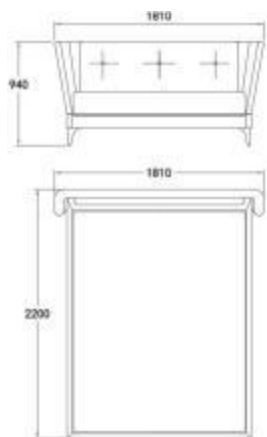







M-06 双人床，腿部为镀铬色金属，靠背及床箱可选皮或者布

Material. 材质

Structure Legs :金属腿

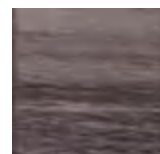

镜面金属

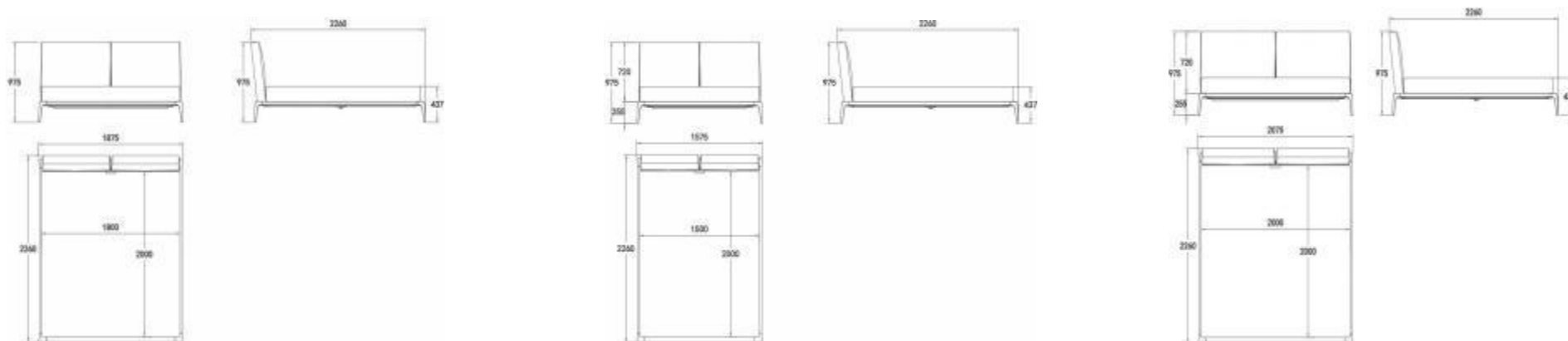



实物拍摄:

尺寸: 191\*225\*H95, 5

材质: 后背皮及床箱 cat. 2HS-BOXER-09

靠包 FAB. 1: MY-A2842-10A

镜面枪黑金属脚





双人床，腿部为黑色哑光金属，靠背羽绒填充，靠背及床箱可选皮或者布

Material. 材质 Structure

Legs :金属腿

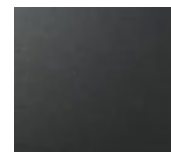

黑色哑光

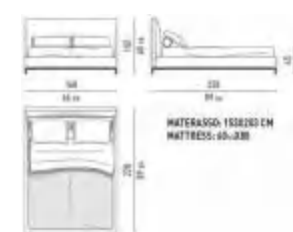
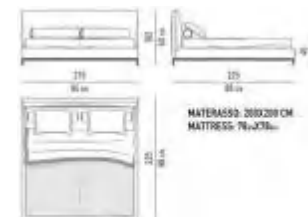





B- 102A 双人床，清晰的几何分割线条，极具艺术气质，舒适与美兼具，也是对当代艺术的致敬。

Material. 材质

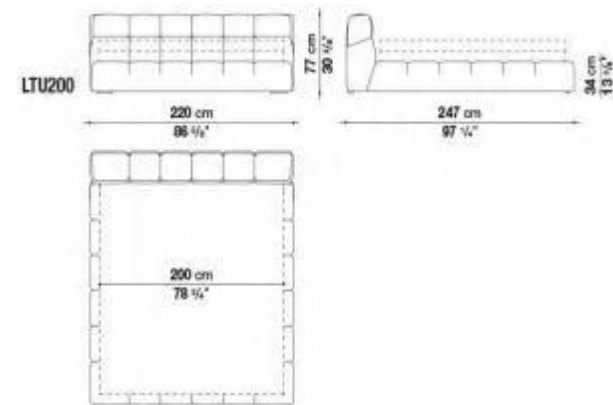
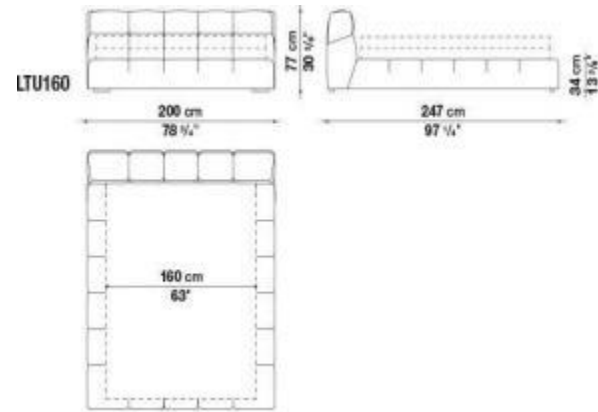
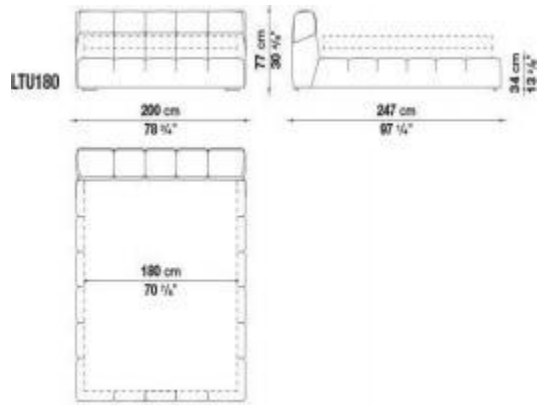



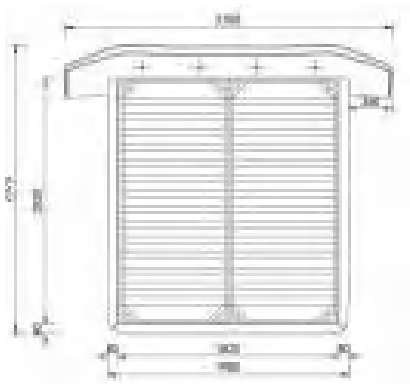





1500\*2000床垫  
1800\*2000床垫  
2000\*2000床垫













这一系列的产品采用更具现代感和装饰性的手法来重新诠释70年代的线条设计，将精致的材料与仿若浑然天成的几何结构完美结合在一起。

支撑脚为浅铜色漆面的哑光金属材质，使支撑结构展现出漂浮一般的效果，Moka色橡木环绕四周，搭配大理石台面或黑色玻璃台面。



### Material.材质

Structure Legs :金属腿



哑光金棕色

Mood Cabinet:柜体



摩卡橡木

Marble desktop. 理石桌面:



金纹爵士白

啡慕斯

进口啡网

劳伦黑金





实物拍摄：

尺寸：75\*55\*45H

材质：面板：金纹爵士白大理石

柜体：摩卡橡木

腿：金棕色艺术漆





这一系列的产品采用更具现代感和装饰性的手法来重新诠释70年代的线条设计，将精致的材料与仿若浑然天成的几何结构完美结合在一起。

支撑脚为浅铜色漆面的哑光金属材质，使支撑结构展现出漂浮一般的效果，Moka色橡木环绕四周，搭配大理石台面或黑色玻璃台面。



## Material.材质

Structure Legs :金属腿



哑光金棕色

Mood Cabinet:柜体



摩卡橡木

Marble desktop. 理石桌面:



金纹爵士白

啡慕斯

进口啡网

劳伦黑金

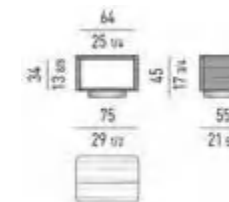
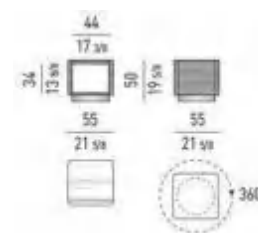



F007-M 床头柜，简约精致的线条极致的诠释了现代主义风格，雅致的米白亮光烤漆面板与金属拉手极具视觉冲击。

Material. 材质

PaintDrawer. 烤漆抽屉：

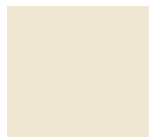

米白亮光烤漆

Metal handle: 金属拉手



石墨色艺术漆

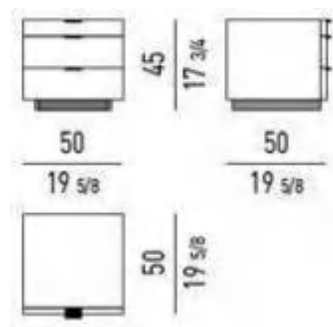

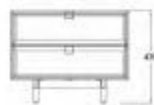
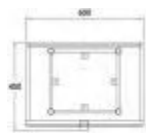

F007-M 床头柜，桌面面板及侧板为摩卡橡木，腿部为摩卡色实木，抽屉面板为米白亮光烤漆

Material. 材质

Outside/Leg Mood. 外侧,腿木材 :



摩卡橡木

Metal handle:金属拉手

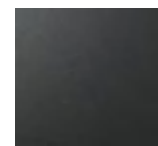

黑色哑光漆

PaintDrawer. 烤漆抽屉 :

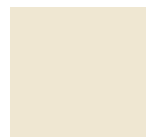

米白亮光烤漆





F005-M 床头柜，桌面面板及金属腿为哑光拉丝枪黑，抽屉面板为大象灰亮光烤漆，柜体侧板为摩卡橡木。

### Material.材质

Structure Legs/Desktop :金属腿/桌面



哑光拉丝枪黑

Outside Mood. 外侧木材 :



摩卡橡木

PaintDrawer. 烤漆抽屉 :

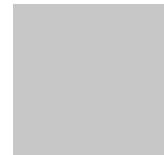

大象灰

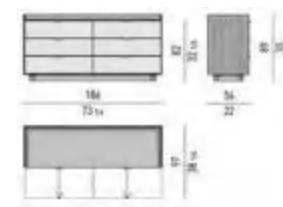
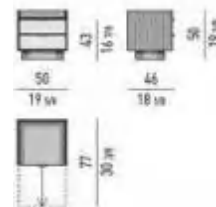



500\*460\*570



Material.材质

Paint Drawer.烤漆面板:



鸽灰色

Top Drawer.玻璃桌面:



黑色玻璃

Marbledesktop.理石桌面:



金纹爵士白

啡慕斯

进口啡网

劳伦黑金

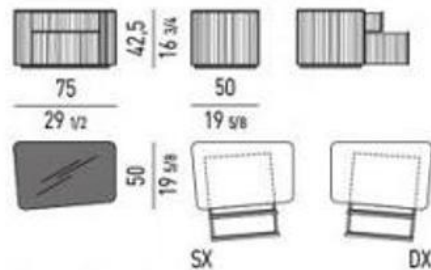



床头柜，桌面及抽屉为黑色橡木贴皮，外侧加厚硬皮，内侧黑色哑光漆金属。



Material. 材质

Mood Desktop Drawer. 木桌面/抽屉 :



黑色橡木

Outer Hard Pack. 外侧硬包:

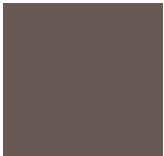

硬皮

Insidemetal. 内侧金属:

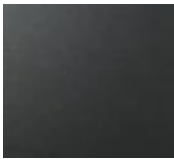

黑色哑光漆

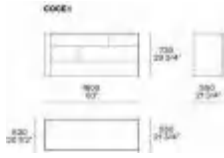
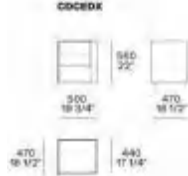
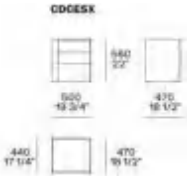



Material.材质

Mood.木面板:



摩卡橡木

Marbledesktop.理石桌面:



金纹爵士白

啡慕斯

进口啡网

劳伦黑金





Material.材质

Paint Drawer.烤漆面板:



冷灰色烤漆

Outside Mood.外侧木材:



黑色橡木

Metal :金属腿



石墨色艺术漆

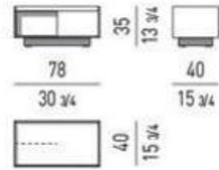



床头柜，整体熏黑橡木山纹。

Material. 材质

Material. 木材：

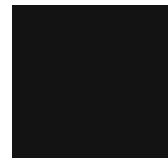

摩卡橡木

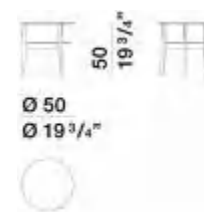
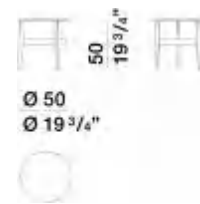



570\*440\*380



465\*465\*470

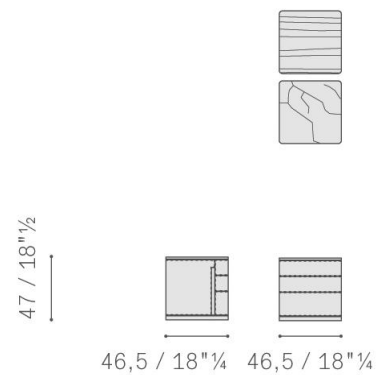

600\*450\*470

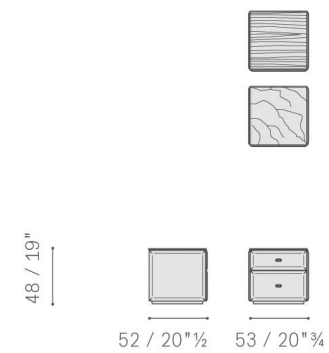



电视柜系列拒绝一成不变的风格，充分运用客制化的理念，加入全新元素和饰面，打造独具魅力的产品系列，多种解决方案使其可以用于任何家居环境中。构架采用全新橡木开孔漆面，颜色为烟草色和Moka色。柜门和抽屉面板采用斜切边缘的设计，除了有皮革包覆的面板以外，还有各种颜色的亮光漆可供选择。



Material. 材质

Outside/Leg Mood. 外侧,腿木材 : PaintDrawer. 烤漆面板 :



摩卡橡木



米白亮光烤漆

大象灰

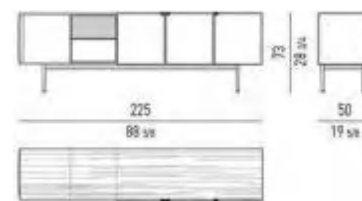

Gray glass:茶灰色玻璃





F003-P 边柜，桌面面板及抽屉为黑色橡木，腿部金属喷涂黑色哑光漆，拉手为哑光拉丝枪黑

Material. 材质

Structure Legs :金属腿

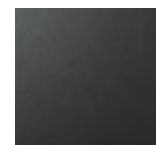

黑色哑光漆

Metal handle:金属拉手



哑光拉丝枪黑

Mood Desktop Drawer. 木桌面/抽屉 :



黑色橡木

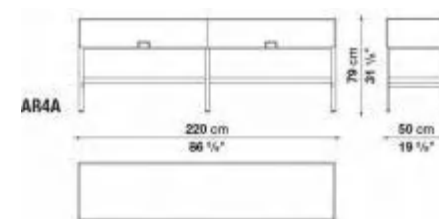



实物拍摄：

尺寸：220\*50\*79H

材质：面板及柜体：黑色橡木

腿：黑色哑光漆

拉手：石墨哑光拉丝

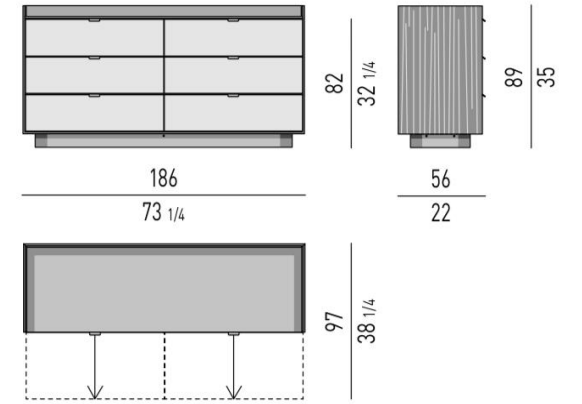



**COCE1**

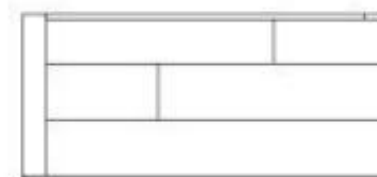

730  
28 3/4"



550  
21 3/4"

1600  
63"

520  
20 1/2"



550  
21 3/4"



W1910\*D610\*H500MM



116 / 45" <sup>3</sup>/<sub>4</sub>

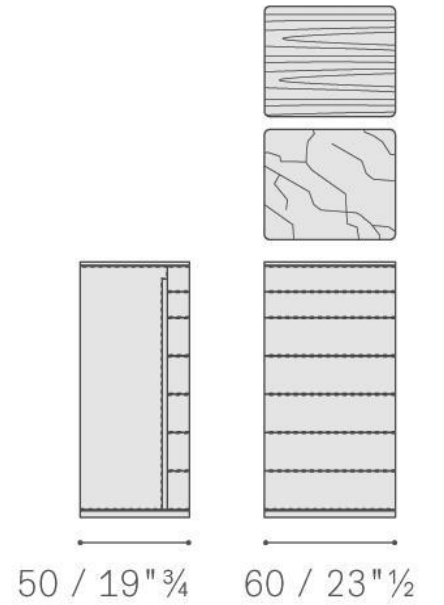



65 / 25"½

53 / 20"¾

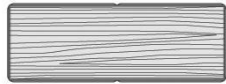

150 / 59"



118 / 46"½

53 / 20"¾

53 / 20"¾





65 / 25"½

53 / 20"¾

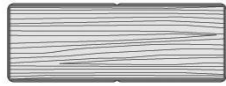

150 / 59"



118 / 46"½

53 / 20"¾

53 / 20"¾





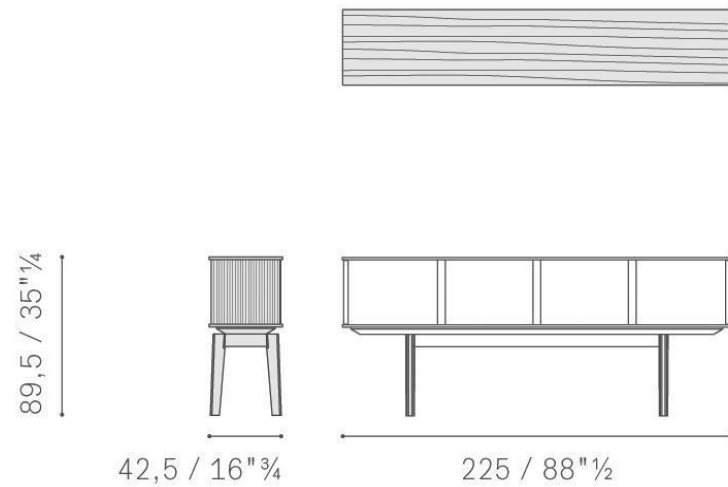
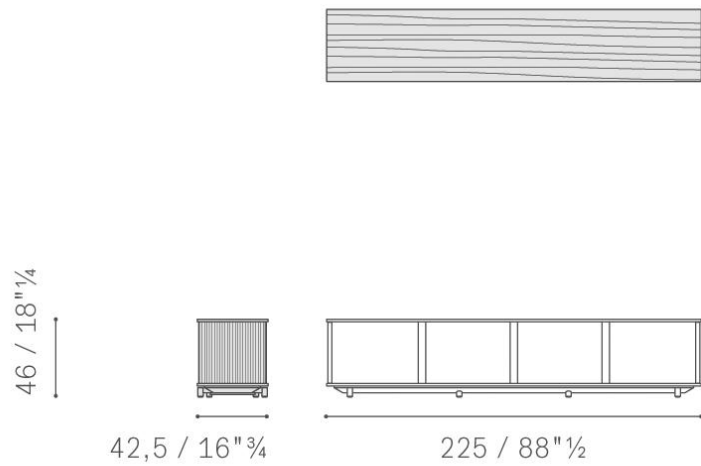



2200\*540\*720MM

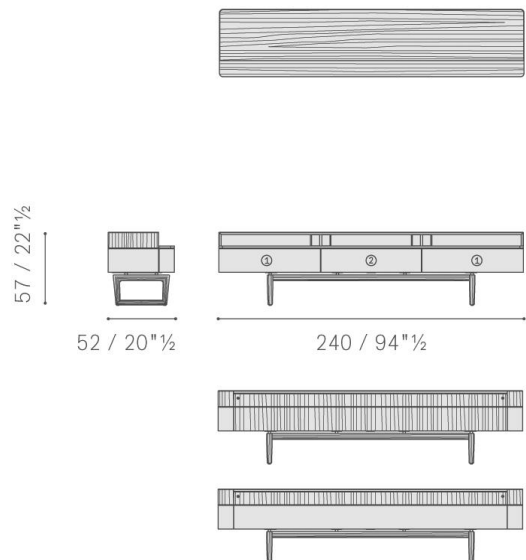



2200\*540\*720MM

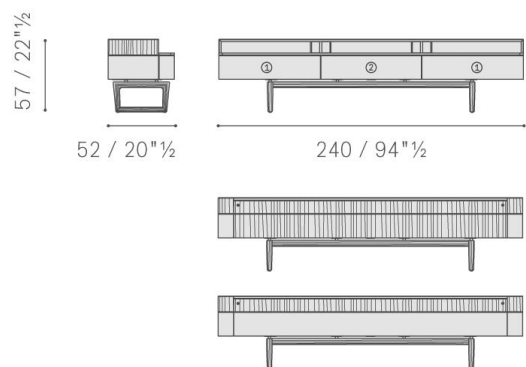
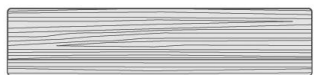

沙发背几简约精致，搭配模块沙发相得益彰。

Material.材质

Outside Mood.外侧木材:



鲍迪豆木皮

Metal :金属腿



金棕色艺术漆

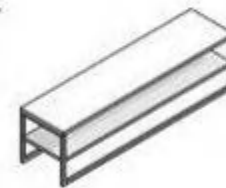
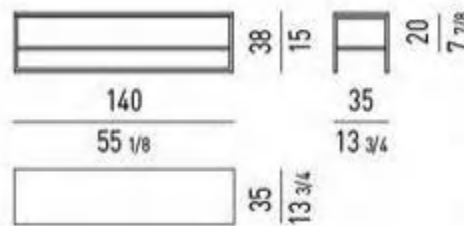



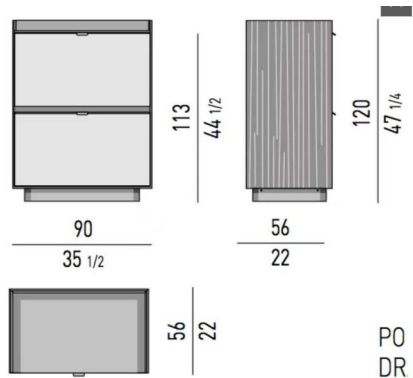

980\*980\*1160MM

1330\*380\*1630MM

M-173L书桌，面板为黑色橡木贴皮，腿部为黑色实木

Material.材质

Material.材质  
Mood desktop/Leg. 木桌面/腿



黑色橡木

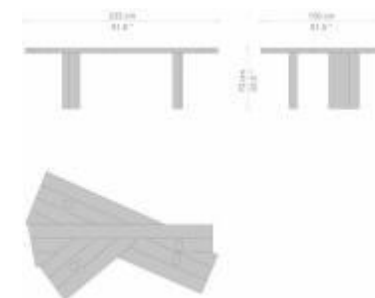







M-231-L 书桌，考究的材料组合和精益求精的细节让 这款写字台备显优雅精致.

Material. 材质

Structure desktop :桌面金属



金棕色艺术漆

Moo d desktop. 木桌面



大象灰

Moo d Leg. 木腿

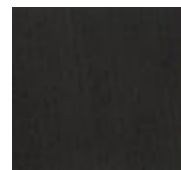

摩卡橡木

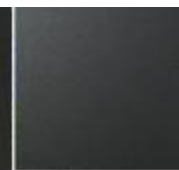

黑色哑光漆

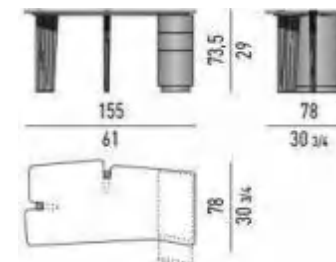





M- 173书桌，金属脚及底座表面喷涂铜拉丝做旧艺术漆，桌面摩卡橡木贴皮，抽屉面板摩卡亮光烤漆。

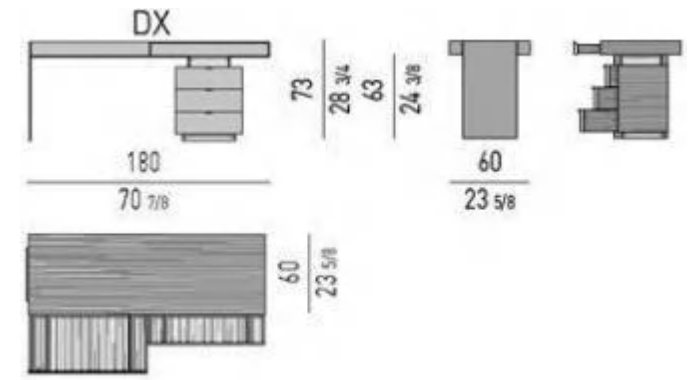

**Material.材质**

Structure Legs :金属腿

Moood desktop.木桌面 : Drawer.抽屉 :



古铜拉丝



摩卡橡木



摩卡亮光烤漆



实物拍摄：

尺寸：180\*65\*75H

材质：面板：摩卡橡木贴皮

抽屉：摩卡亮光烤漆

腿及底座：铜拉丝做旧





W2200\*D1000\*H750MM



2315\*720\*683MM



600\*550\*835MM

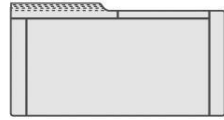

73 / 28<sup>3</sup>/<sub>4</sub>"  
63 / 26<sup>3</sup>/<sub>4</sub>"



66,5 / 26"  
71 / 28"

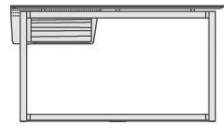

136,5 / 53<sup>3</sup>/<sub>4</sub>"



1200\*725\*730MM

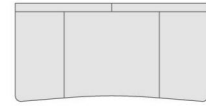

75 / 29<sup>1</sup>/<sub>2</sub>"



91,5 / 36"



183 / 72"

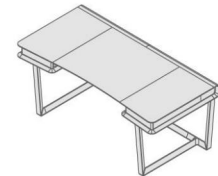

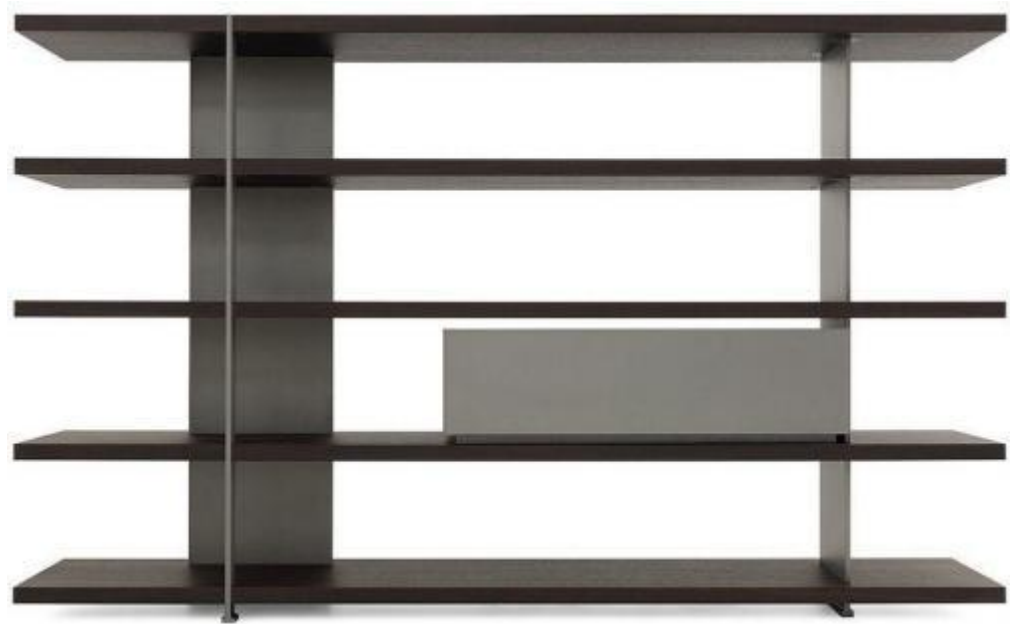

Material. 材质

Metal. 金属立板：



金棕色艺术漆

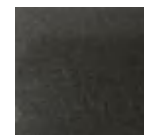

石墨色艺术漆



哑光拉丝枪黑

Mood. 木面板：



摩卡橡木



大象灰







2800\*425\*1660MM

# 面料等级：FAB.1

## Composizione / Composition

Viscosa | Viscose  
 Acrilico | Acrylic  
 Poliestere | Polyester  
 Lino | Linen  
 Lana | Wool  
 Cotone | Cotton  
 Nylon | Nylon

## Indicazioni di lavaggio | Washing instructions



MY-  
A2672-  
4A



MY-  
A2672-  
3A



MY-  
A2940-  
13A



MY-  
A2940-



MY-  
A2940-



MY-  
A2976-



MY-  
A2977-



MY-  
A2976-



MY-  
A2976-



NH-  
5790-

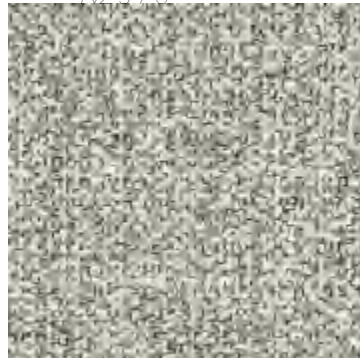

MY-  
A2842-  
1A

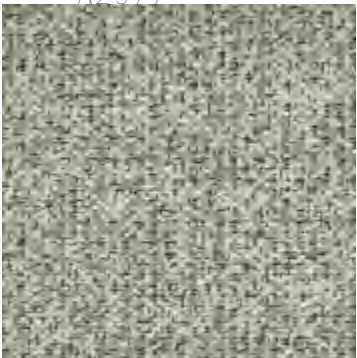

MY-  
A2842-  
10A



NH-  
50115-  
14



MY-  
A2267-  
1A



NH-  
62799-  
4

# 面料等级：FAB.1

## Composizione / Composition

Viscosa | Viscose  
 Acrilico | Acrylic  
 Poliestere | Polyester  
 Lino | Linen  
 Lana | Wool  
 Cotone | Cotton  
 Nylon | Nylon

## Indicazioni di lavaggio | Washing instructions

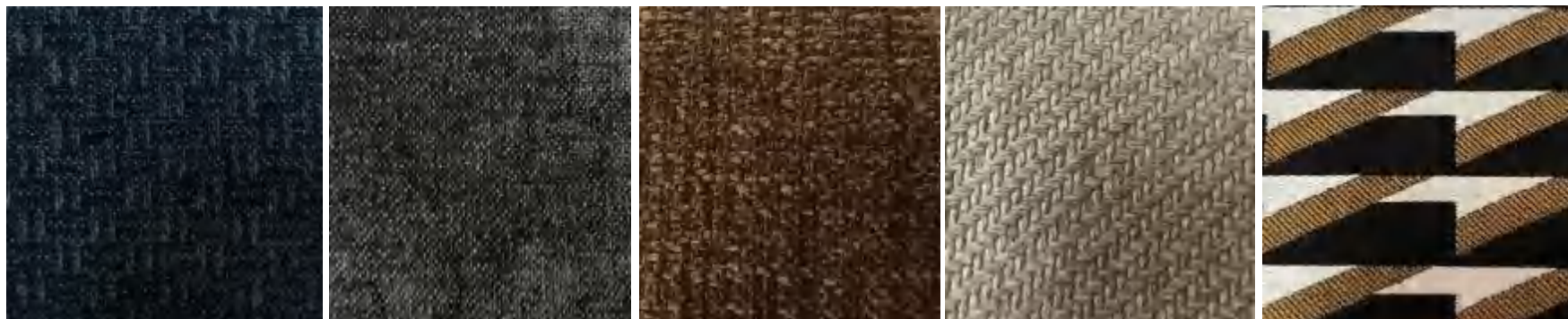

NB 201  
2- 4A

NB 201  
2-

NB 201  
2- 8D

NB 201  
2- 9B

NB 104  
9-



NB 104  
6-

NB 104  
6- 16

NB 104  
6- 26

NB 104  
6- 4B

NB 104  
6- 27



NB 700  
1- 3

NB 700  
1- 9

NB 700  
1- 8

LY-  
BRONX-  
BORDEAU  
X

NB 201  
2-  
12F

# 面料等级：FAB.1

## Composizione / Composition

Viscosa | Viscose  
Acrilico | Acrylic  
Poliestere | Polyester  
Lino | Linen  
Lana | Wool  
Cotone | Cotton  
Nylon | Nylon

## Indicazioni di lavaggio | Washing instructions



MY-  
A2983-  
15



MY-  
A2983-  
10AP



MY-  
A2989-  
7AF

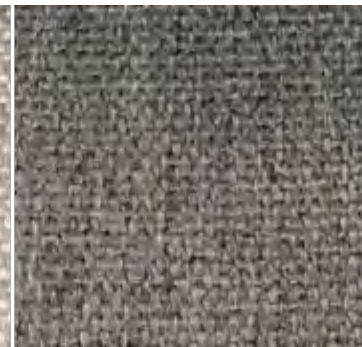

MY-  
A2983-  
7AF

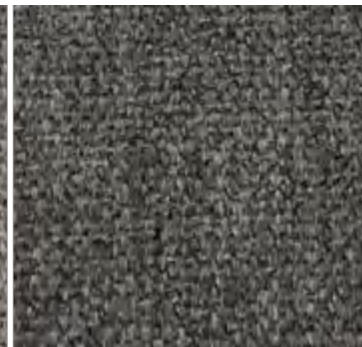

MY-  
A2983-  
7AP



MY-  
A2976-  
2A



MY-  
A2989-  
2A



MY-A2989-  
6A



MY-  
A2989-  
7A

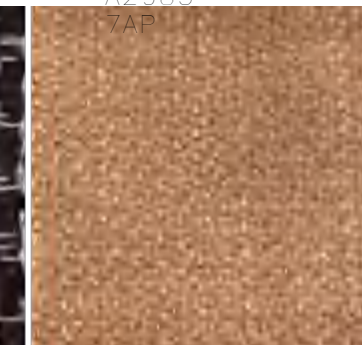

NH-  
51217-  
147

## 面料等级：FAB.3

### Composizione / Composition

Viscosa | Viscose  
Acrilico | Acrylic  
Poliestere | Polyester  
Lino | Linen  
Lana | Wool  
Cotone | Cotton  
Nylon | Nylon

### Indicazioni di lavaggio | Washing instructions



NB 701  
7- 1



NB 701  
7- 2

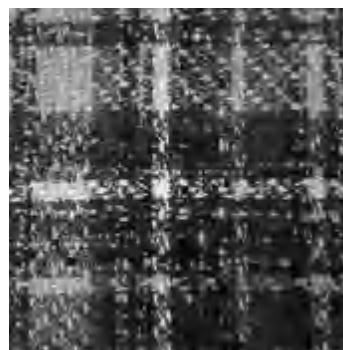

NB 701  
7- 3

皮料等级：CAT.2

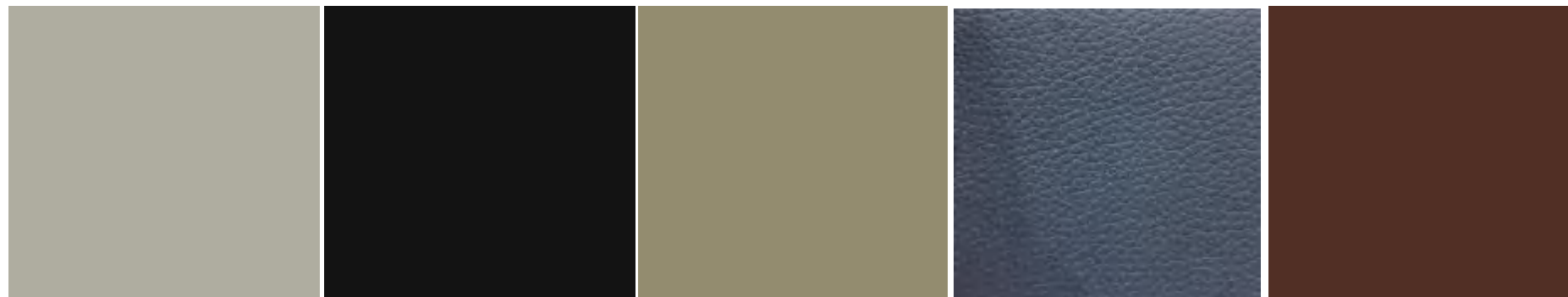

HS-  
BOXER-

HS-  
BOXER-

HS-  
BOXER-

HS-  
BOXER-

HS-  
BOXER-

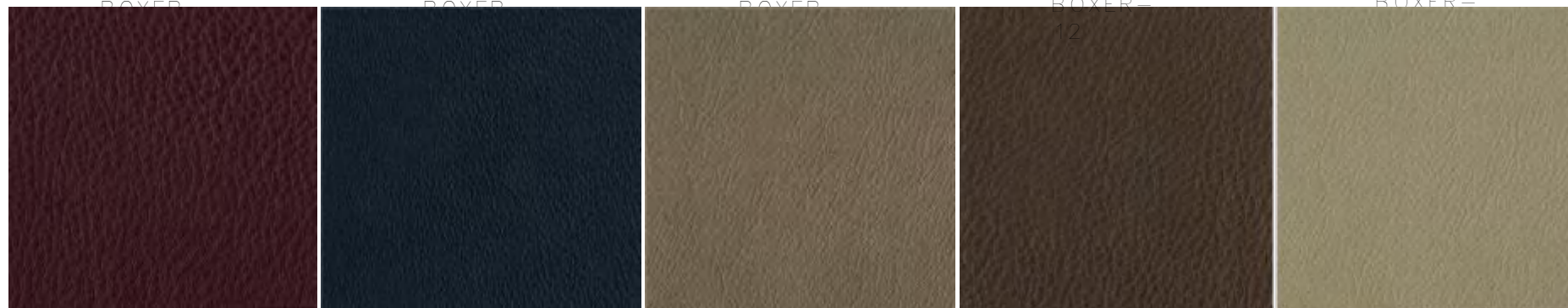

HS-  
BOXER-

HS-  
BOXER-

HS-

HS-

HS-

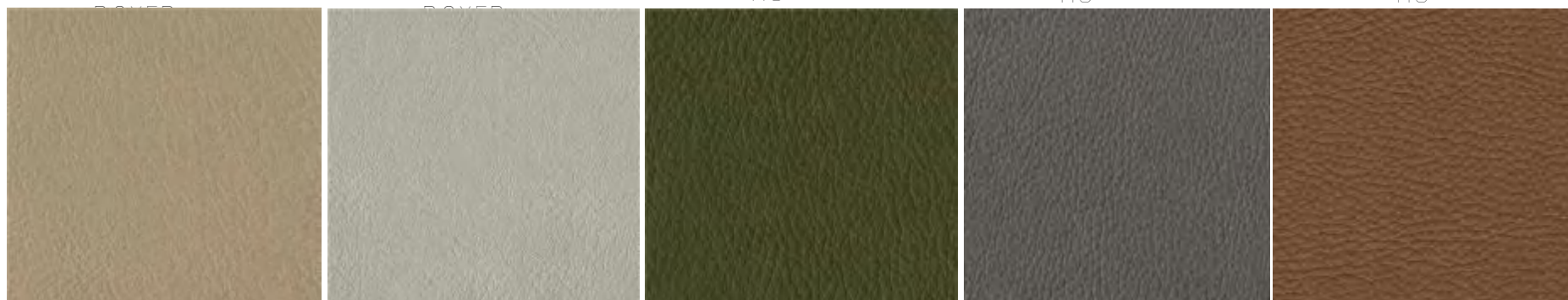

HS-  
BOXER-  
20

HS-  
BOXER-  
22

HS-  
BOXER-  
04

HS-  
BOXER-  
05

HS-  
BOXER-  
19

皮料等级: CAT.3



HS-  
101  
03



石材:



金纹爵士白

啡慕斯

进口深啡网

劳伦黑金

木饰面:

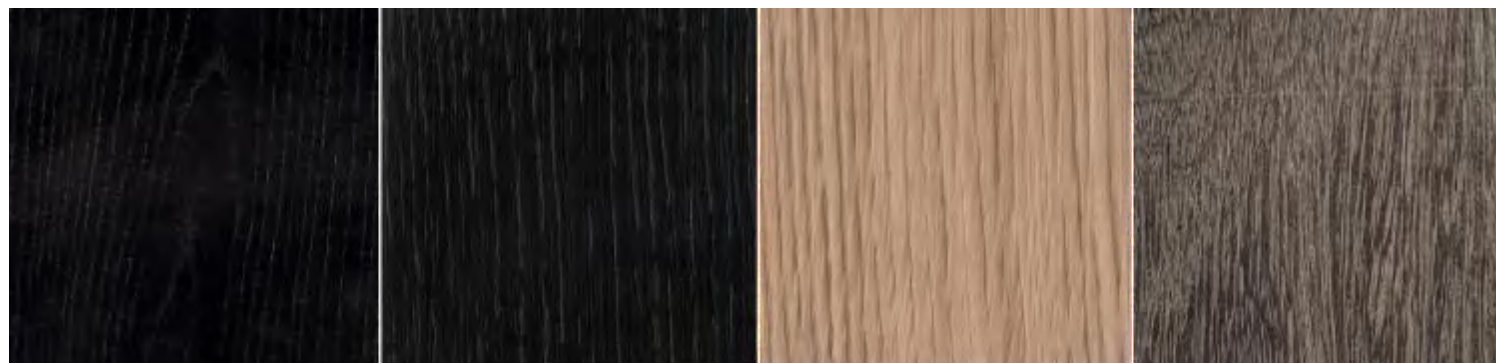

黑色橡木

摩卡橡木

白橡

鲍迪豆

烤漆面:

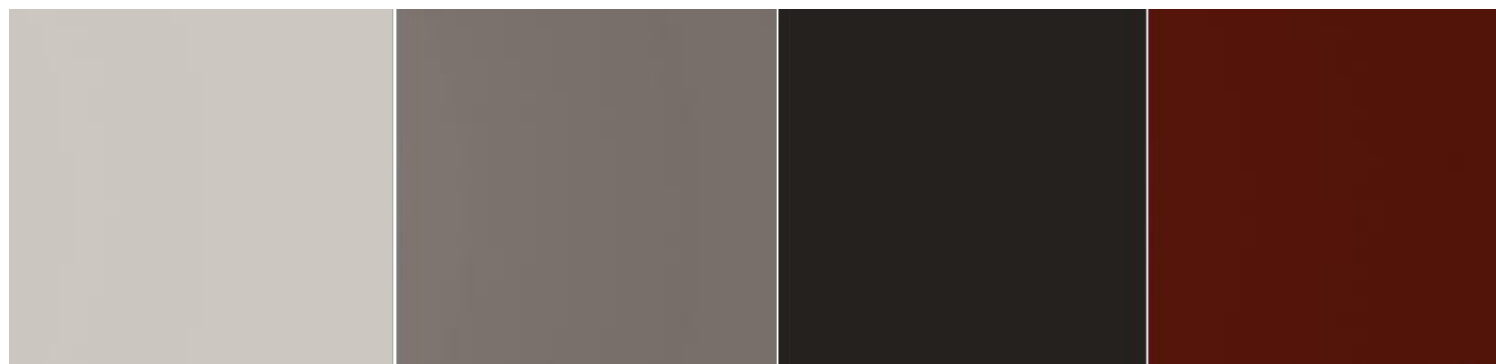

米白

大象灰

摩卡

酒红